

DRG. NO. 29P0069

DIMENSIONS ARE IN mm.
 UNTOLERATED DIMENSIONS AS PER IS. 2102 (MEDIUM)

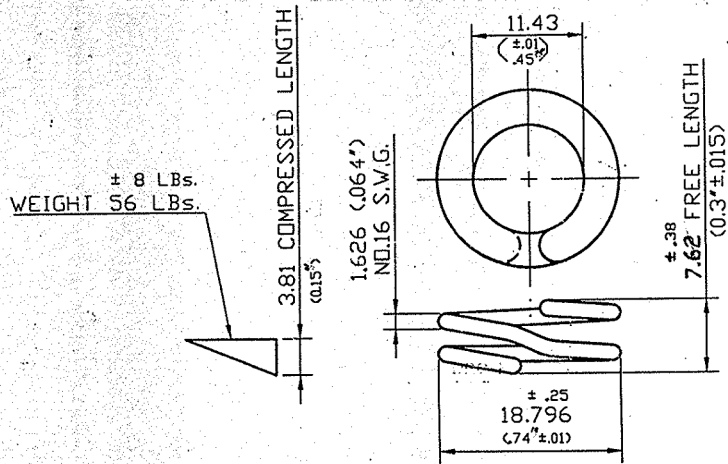



SPRING TO BE TESTED BEFORE GAUGING BY COMPRESSION COIL ON COIL FOR A PERIOD OF 12 HOURS. AFTER WHICH IT MUST CONFORM TO THE FREE LENGTH SHOWN

MATERIAL: STEEL BS.5770, Pt.2, 1981, Gr.080.

NOTE:-
 AN APPROVED TRADE PATTERN WILL BE ACCEPTED

TREATMENT:-
 HRD. & SPRING TEMPD. ANTI-RUST FINISH TYPE-C AFTER HEAT TREATMENT.

PART NO.	DESCRIPTIONS	NO OFF	MATERIAL	TREATMENT	REMARKS
	 SIGNATURE & DATE TRACED DRAWN <i>R. Senthil</i> CHECKED <i>R. Senthil</i> OIC/D&DO <i>V. Valluvaran</i> PRDN. OFFICER DIV. OFFICER D&DO APPROVED ON: 10/04				SUB: WASHER, SPRING, BOLT STOCK SCALE 2:1 FOR: .315" SPORTING RIFLE STORE DRG. NO. DES. REF. NO: SP-69 OPERATION NO. DRG. NO: 29P0069  ORDNANCE FACTORY TIRUCHIRAPALLI-16. SHEETS: 1 SHEET NO: 1
AMENDMENTS	SIG. & DATE				