

DRAWING NO.
172.51.016/F

ISSUE	MODIFICATION	DATE
A	REDRAWN	
B	ALTERNATE MATERIAL INCL. REF. JT.GM/P&TD Ltr 03512(7)/PDO/T-72/2K2 DT.12.3.02(VACUM DEGASSED)	
C	ALT.MATERIAL,VACUM DEGASSED STEEL IS DELETED. REF. Jt.GM/C&S LTR NO.HVF/IFD/ 071040/2K2-2K3/AJY/STL/AJYFA DT.14.06.02	
D	ISOTHERMAL ANNEALING IS ADDED.REF.RG LTR NO. 07271/RG/T-72 TORSION BAR/ 09-10 DT.19.03.2010 REDRAWN	13/3/10

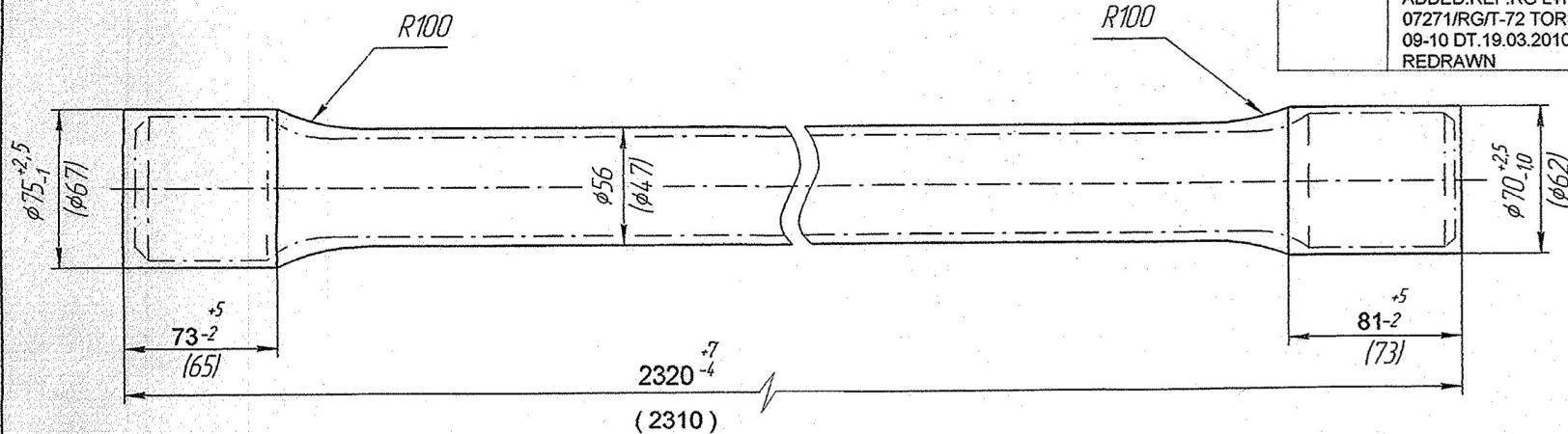

MATERIAL:- 45XH2MΦA-W
GOST 4543-71
(TY-14-1-1725-76)

T-72

TECHNICAL REQUIREMENTS

- MARK HEAT NUMBER, BATCH NUMBER AND PART NUMBER.
- HEAT TREAT: ISOTHERMAL ANNEALING 255 BHN MAX. (D)
- BEND UP TO 1.5 MM ALONG THE AXIS OF $\phi 56$ IS ALLOWED. AFTER ANNEALING.
- GRINDING SURFACE DEFECTS AND SCALE PITS ARE ALLOWED. WITHIN 0.5 OF ACTUAL ALLOWANCE.
- FORGING FIN UP TO 2 MM IS ALLOWED.
- RUNOUT OF HEAD IN RELATION TO SHANK IS ALLOWED UP TO 3 MM. RUNOUT IS TO BE CHECKED TO A LENGTH OF 200 MM FROM THE HEAD FACE. RUNOUT OF HEAD IS TO BE CHECKED IN 50 MM LENGTH FROM THE FACE.
- ELLIPTICITY OF HEAD SHOULD NOT EXCEED 2 MM.
- FACIAL FIN IS ALLOWED UP TO 6 MM.
- MISMATCH IS ALLOWED UP TO 1 MM.
- ELLIPTICITY AT THE PLACE OF GRIPPING IS ALLOWED WITH MINIMUM 54 MM DIMENSION.
- MACHINING DIMENSIONS ARE SHOWN IN BRACKETS.
- UN TOLERANCED DIMENSIONS ARE NOT TO BE CHECKED.

MATERIAL	FORGING WT.	
45XH2MΦA-W GOST 4543-71 (TY-14-1-1725-76)	46.9 Kgs	
ALT. MATERIAL	HAMMER	SCALE
		NTS
DRAWN	CHECKED	APPROVED
DRAWING NO. 172.51.016/F		
NOMENCLATURE: SHAFT TORSION-FORGING		
HEAVY VEHICLES FACTORY AVADI, CHENNAI		