

DRG. NO. K-2050

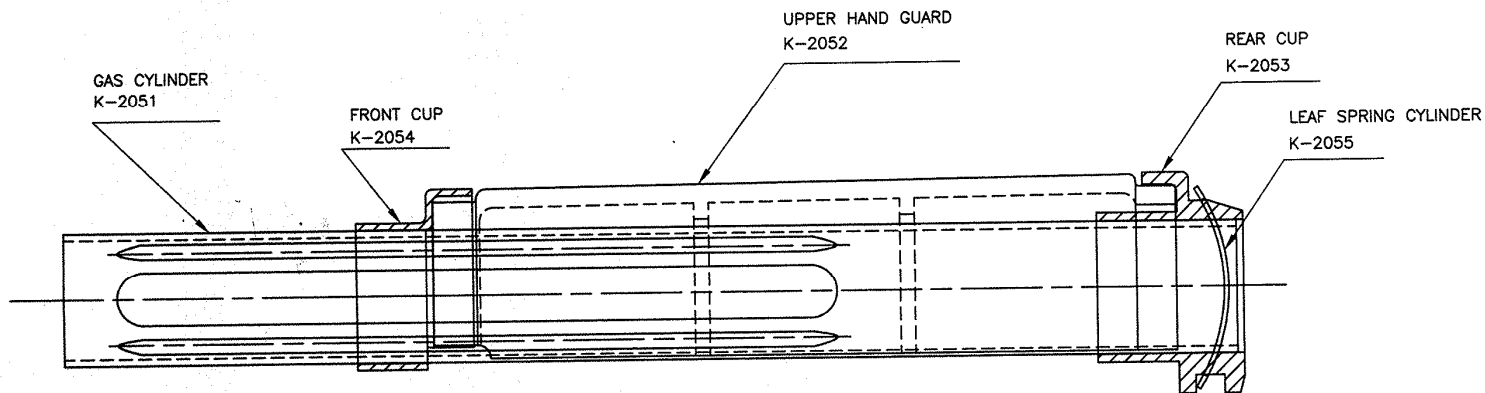

NOTE: FRONT CUP AND REAR CUP ARE TO BE SPOT WELDED TO GAS CYLINDER

K-2050

DIMENSIONS ARE IN mm.  
 UNTOLERATED DIMNS. AS PER IS : 2102 (MED)  
 MARK DRAWING No.

*S. K. Rao*  
 DGM/PROJECT

PART NO.		DESCRIPTIONS	NO OFF	MATERIAL	TREATMENT	REMARKS
		UPPER HAND GUARD ASSY				
TRACED DRAWN CHECKED HOS/D&DO OFFICER/PRODN. OFFICER/D&DO		SIGNATURE & DATE.  SUB: UPPER HAND GUARD ASSY FOR: OF: TRICHY ASSAULT RIFLE DES. REF. NO. DRG. No.: TAR-K-2050				SCALE NTS STORE DRG. NO. K-2050 OPERATION NO. ---- SHEETS: 1 SHEET No.: 1
AMENDMENTS	SIG. & DATE	APPROVED ON. 20.06.2016				(FT) ORDNANCE FACTORY TIRUCHIRAPPALLI-16.

DRG. NO. K-2051

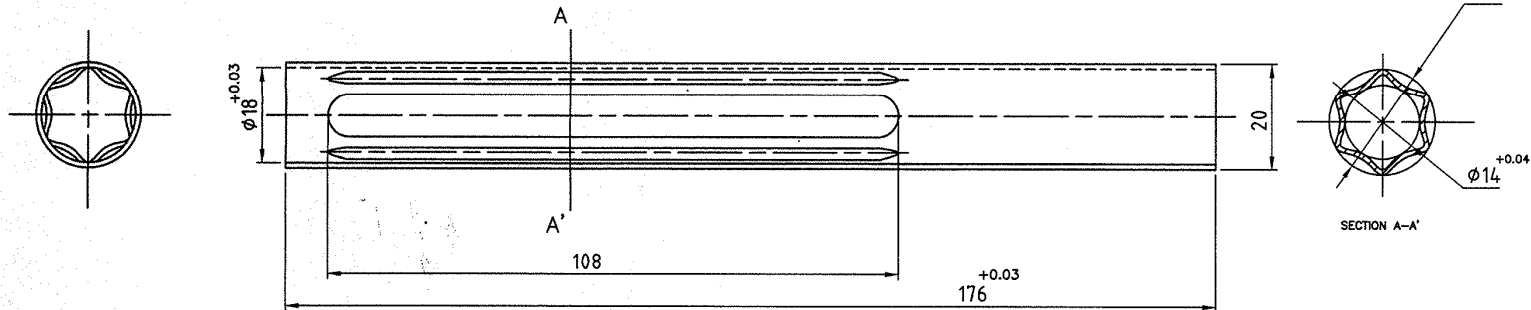

MATERIAL : BS 6323 PT 4:1982 DES CF S11 BK  
 (OR) BS 6323 PT 4:1982 DES CF S10 BK

HT/HARDNESS : HARDENED AND TEMPERED TO 360-440 HV

PROTECTIVE FINISH :- PHOSPHATE TO SPECN. JSS 0465-01:1994,  
 CLASS II (ACCELERATED), OIL FINISH.

DIMENSIONS ARE IN mm.  
UNTOLERATED DIMNS. AS PER IS : 2102 (MED)  
MARK DRAWING No.

K-2051

*G. K. a*  
 DGM/PROJECT

AMENDMENTS	SIG. & DATE

PART NO.	DESCRIPTIONS	NO OFF	MATERIAL	TREATMENT	REMARKS
	GAS CYLINDER				
	SIGNATURE & DATE.	SUB: GAS CYLINDER			SCALE
	TRACED	FOR: UPPER HAND GUARD ASSY			STORE DRG.NO.
	DRAWN	OF: TRICHY ASSAULT RIFLE			K-2051
	CHECKED	DES. REF. NO.			OPERATION NO.
	HOS/D&DO	DRG. No.: TAR-K-2051			----
	OFFICER/PRODN.	 ORDNANCE FACTORY TIRUCHIRAPPALLI-16.			SHEETS: 1
	OFFICER/D&DO				SHEET No.: 1
	APPROVED ON. 20.06.2016				

DRG. NO. K-2052

DIMENSIONS ARE IN mm.  
 UNTOLERATED DIMNS. AS PER IS : 2102 (MED)  
 MARK DRAWING No.

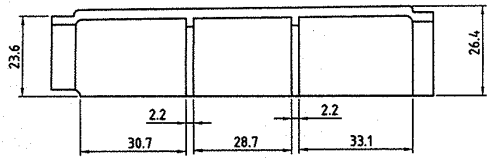

SECTIONAL VIEW

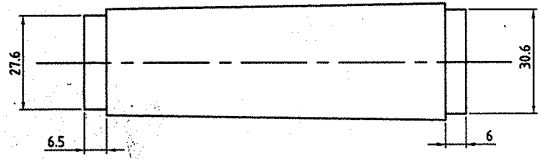

TOP VIEW

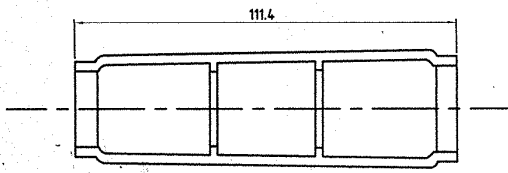
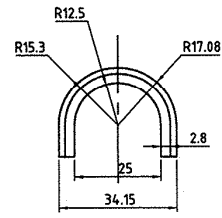
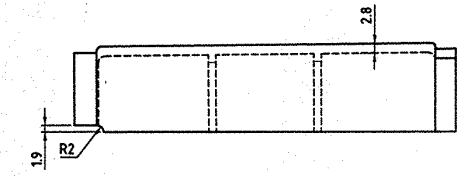
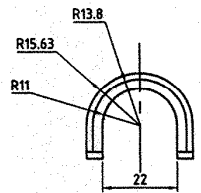

BOTTOM VIEW

MATERIAL:  
 GLASS FIBRE REINFORCED POLYAMIDE (NYLON 6 or 66)  
 MELTING POINT : NOT LESS THAN 200° C  
 COLOUR : MATT FINISH BLACK

K-2052

*S. K. S.*  
 DGM/PROJECT

AMENDMENTS	SIG. & DATE

UPPER HAND GUARD		NO OFF	MATERIAL	TREATMENT	REMARKS
PART NO.	DESCRIPTIONS				
TRACED	SIGNATURE & DATE.		SUB: UPPER HAND GUARD		SCALE
DRAWN			FOR: UPPER HAND GUARD ASSY		STORE DRG.NO.
CHECKED			OF: TRICHY ASSAULT RIFLE		K-2052
HOS/D&DO			DES. REF. NO.		OPERATION NO.
OFFICER/PRODN.			DRG. No.: TAR-K-2052		----
OFFICER/D&DO			ORDNANCE FACTORY TIRUCHIRAPPALLI-16.		SHEETS: 1
APPROVED ON. 20.06.2016					SHEET No.: 1





550Z-K ON 'DRG

DIMENSIONS ARE IN mm.

UNTOLERATED DIMS. AS PER IS : 2102 (MED)

MARK DRAWING No.

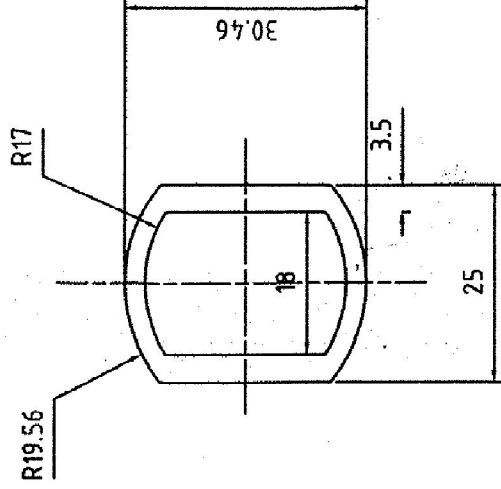

NOTE :- REMOVE ALL SHARP CORNERS

MATERIAL :- B.S 970 Pt-1, 1983 GR 070 A78 ('78' CARBON) (En 42)

BS 970 Pt-1, 1983 GR 070 A72 ('72' CARBON) (En 42)

HT/HARNES : HARDENED AND TEMPERED TO 475 TO 550 HV

PROTECTIVE FINISH :- PHOSPHATE TO SPECN. JSS 0465--01:1994,

CLASS II (ACCELERATED), OIL FINISH.

K-2055

PART NO.		LEAF SPRING CYLINDER		NO OFF		MATERIAL		TREATMENT		REMARKS	
DGM/PROJECT <i>Ge. Karim</i>		DESCRIPTIONS &		SUB: LEAF SPRING CYLINDER		SCALE		1:1		STORE DRG.NO.	
		SIGNATURE & DATE		FOR: UPPER HAND GUARD ASSY		K-2055		OPERATION NO.		XXXXX	
		TRACED		FOR: TRICHY ASSAULT RIFLE		DES.REF.NO.		DRG.		TAR-K-2055	
		DRAWN		DES.REF.NO.		No.:		ORDNANCE FACTORY		SHEETS: 1	
CHECKED		HOS/D&DO		APPROVED ON. 20.06.2016		TIRUCHIRAPPALLI-16.		SHEET No.: 1			
OFFICER/PRODN.		OFFICER/D&DO									
AMENDMENTS		SIG. & DATE		1		2		3		4	