

PLACE FOR PAINTING IDENTIFICATION MARK
(BLACK COLOUR 5mm SIZE)
Pt. No., YEAR OF MANUF., MANUFACTURE BY.

375

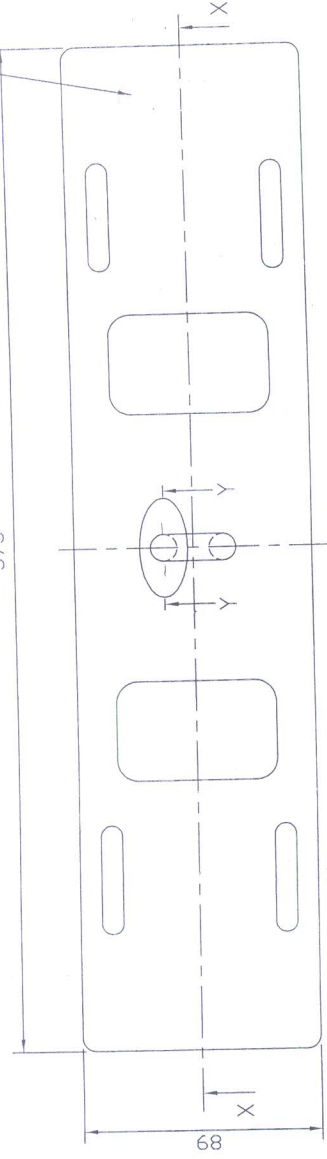

MATERIAL :-
EN-24 TO SPECN BS:970 PART 2 -1970

MANUFACTURING PROCESS :-
GENERAL ENGINEERING METHOD/FORGING

WORKMANSHIP :-
1) PLATE CORNERS TO BE ROUND OFF
2) WELD JOINT SHOULD BE SMOOTHENED
NO SHARP EDGES TO BE FOUND

WELD NOTE :-
JOINT TO BE WELDED WITH ELECTRODE CONFORMING TO
IS: 1395-1982 E63B-MI 29 Fe

FINISH:-
CADMIUM PLATED TO MINIMUM THICKNESS OF 13 MICRON
AND CHROMATE PASSIVATED TO IS:1572-1986 Gr-3

JOINT EXAMINATION :-
VISUAL & LIQUID PENETRANT TEST SHALL BE
CARRIED OUT AS PER IS:3658

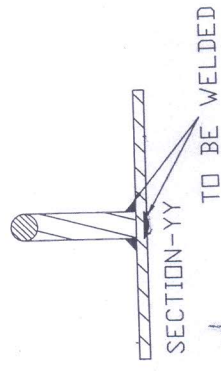
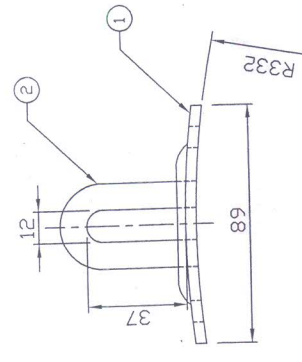
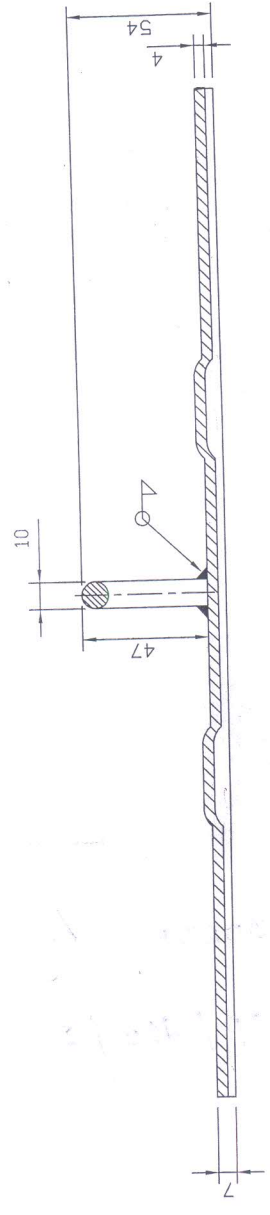

| DTL.No. | NOMENCLATURE | No. OFF | DRG. No. | SHEET No. |
|---------|--------------|---------|----------------------|-----------|
| 2. | HOOK | 1. | 1.6.01-01.07 (prov.) | 3 |
| 1. | PLATE | 1. | 1.6.01-01.07 (prov.) | 2 |

DETAIL INDEX

PACKING NOTE :- EACH ITEM TO BE WRAPPED WITH WATER PROOF PAPER
IN SUCH A WAY SO THAT ID MARK IS VISIBLE

| | | | | |
|-----------------------------------|----------------------|------|-------|---------------------------------|
| SCALE:- 1 : 2 | A D R E A G R A | DRN. | SARNA | PROJ. OFFICER/ GROUP OFFICER |
| DIMENSIONS IN mm | GROUP - CP | CHD. | DUTTA | APPROVED |
| TOL.:- AS PER IS:2102 (Pt.1) 1993 | ASSEMBLY | | | HEAD (PARA) |
| MATERIAL:- | PLATE STIFFENER | | | DRG. NO. |
| FINISH:- | FOR EXTRACTOR | | | ADRDE/ 1.6.01-01.07 |
| HEAT TREATMENT:- | PARACHUTE PACK COVER | | | |
| | HD PARACHUTE SYSTEM | | | |
| | FOR IL-76 AIRCRAFT | | | |

| | | | | | |
|---------|------|------|--------------|---|---|
| REV.No. | DATE | ZONE | AUTHORITY | 7 | 8 |
| | | | BRIEF RECORD | 6 | 5 |
| | | | | 4 | 3 |
| | | | | 2 | 1 |

375

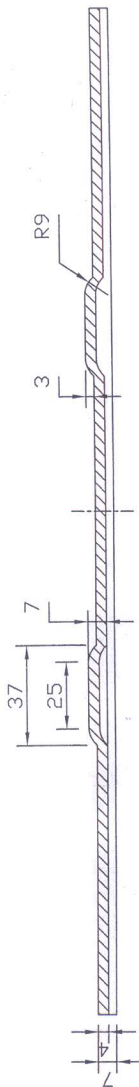
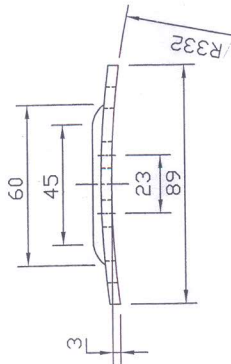
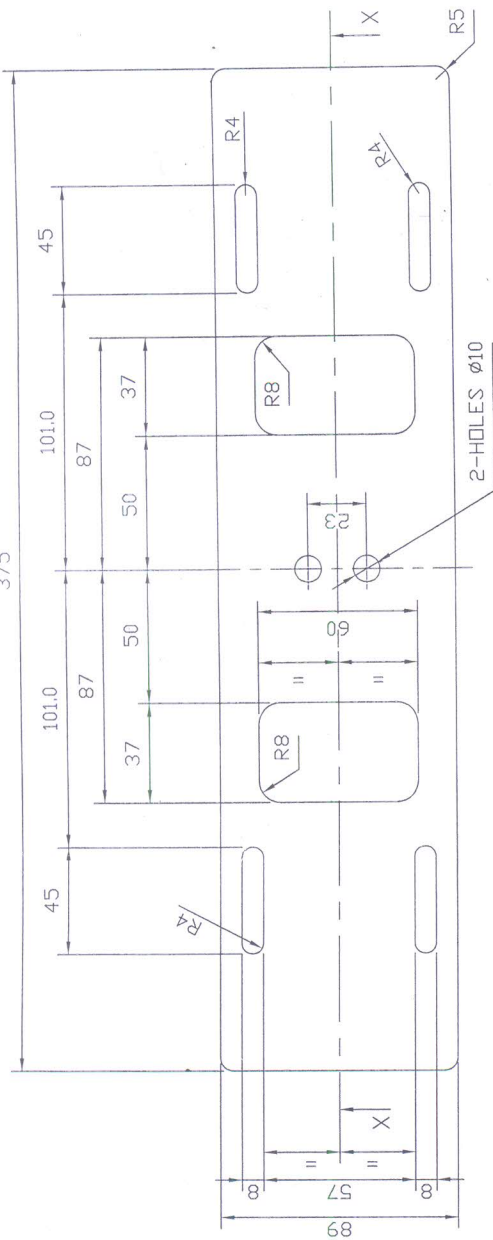

SECTION-XX

1-OFF

| | | | | | |
|--------------------------------------------------------|----------------------------------------------------------|------|-------|----------|---------------------------------|
| SCALE:- 1 : 2 | A D R D E A G R A | DRN | SARNA | APPROVED | PROJ. OFFICER/ GROUP OFFICER |
| DIMENSIONS IN mm | GROUP- CDS | CHD. | DUTTA | APPROVED | HEAD (PARA) |
| TOL:- AS PER IS:G102 (Pt.1) 1991 (CDARSE) | PLATE STIFFENER FOR EXTRACTOR PARACHUTE PACK COVER | | | | DRG. NO. |
| MATERIAL:- ALLOY STEEL 817M40 (EN-24 AS PER BS 970) | HD PARACHUTE SYSTEM (P-7-PLATFROM) | | | | ADRDE/ 1.6.01-01.07 |
| FINISH:- | | | | | |
| HEAT TREATMENT:- 32±5 HRC | | | | | |

| | | | | | | |
|---------|------|------|-----------|--------------|------------|---------------|
| REF.NO. | DATE | ZONE | AUTHORITY | BRIEF RECORD | I/C D&S | HEAD GROUP |
| | | | | | | |

