

0005-K-K 'ON DRG. NO. K-5000

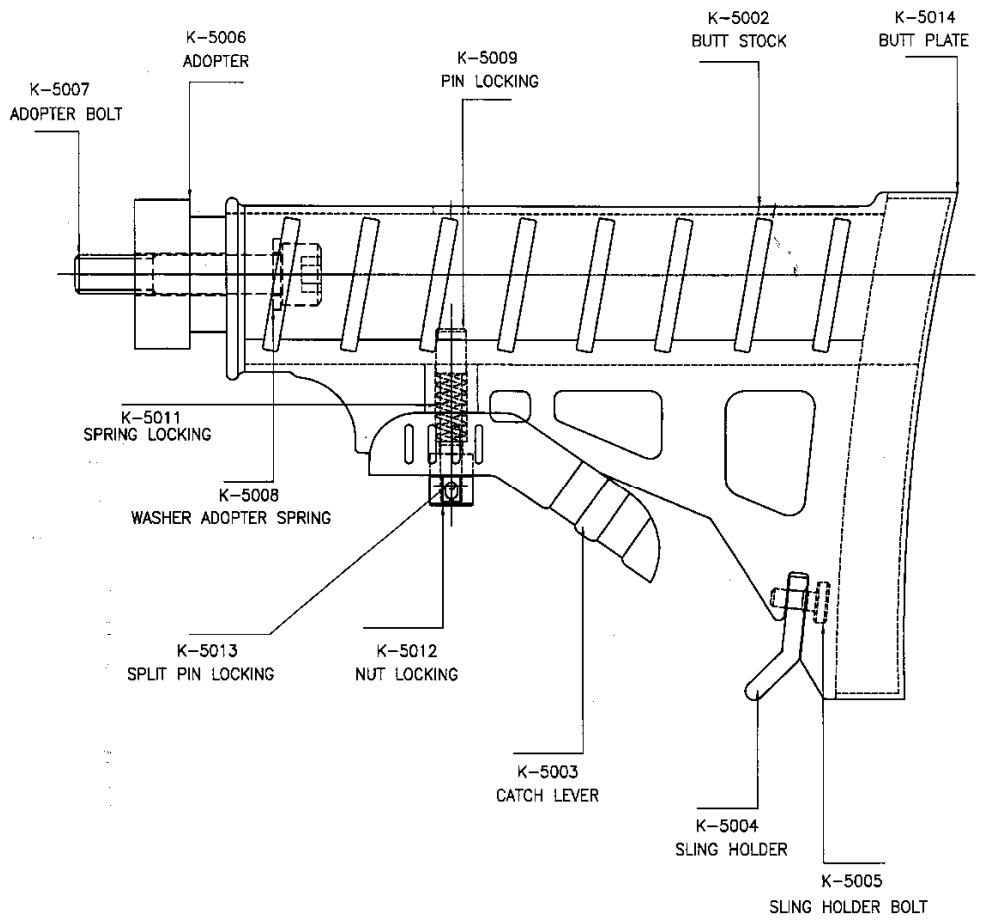

1	EXTENDABLE BUTT ASSY	1	AS ABOVE		
PART NO.	DESCRIPTIONS	QTY	MATERIAL	TREATMENT	REMARKS
1	EXTENDABLE BUTT ASSY	1			SCALE: ---
	FOR: TRICHY ASSAULT RIFLE				STORE DRG. NO. K-5000
	DES. REF. NO.				OPERATION NO. ---
	DRG. No.: TAR-K-5000				
ORDNANCE FACTORY TIRUCHIRAPPALLI-18.					SHEETS: 1
APPROVED ON: 17.08.2019					SHEET No.: 1

DGM/PROJECT  
 SIG. & DATE  
 APPROVED ON: 17.08.2019

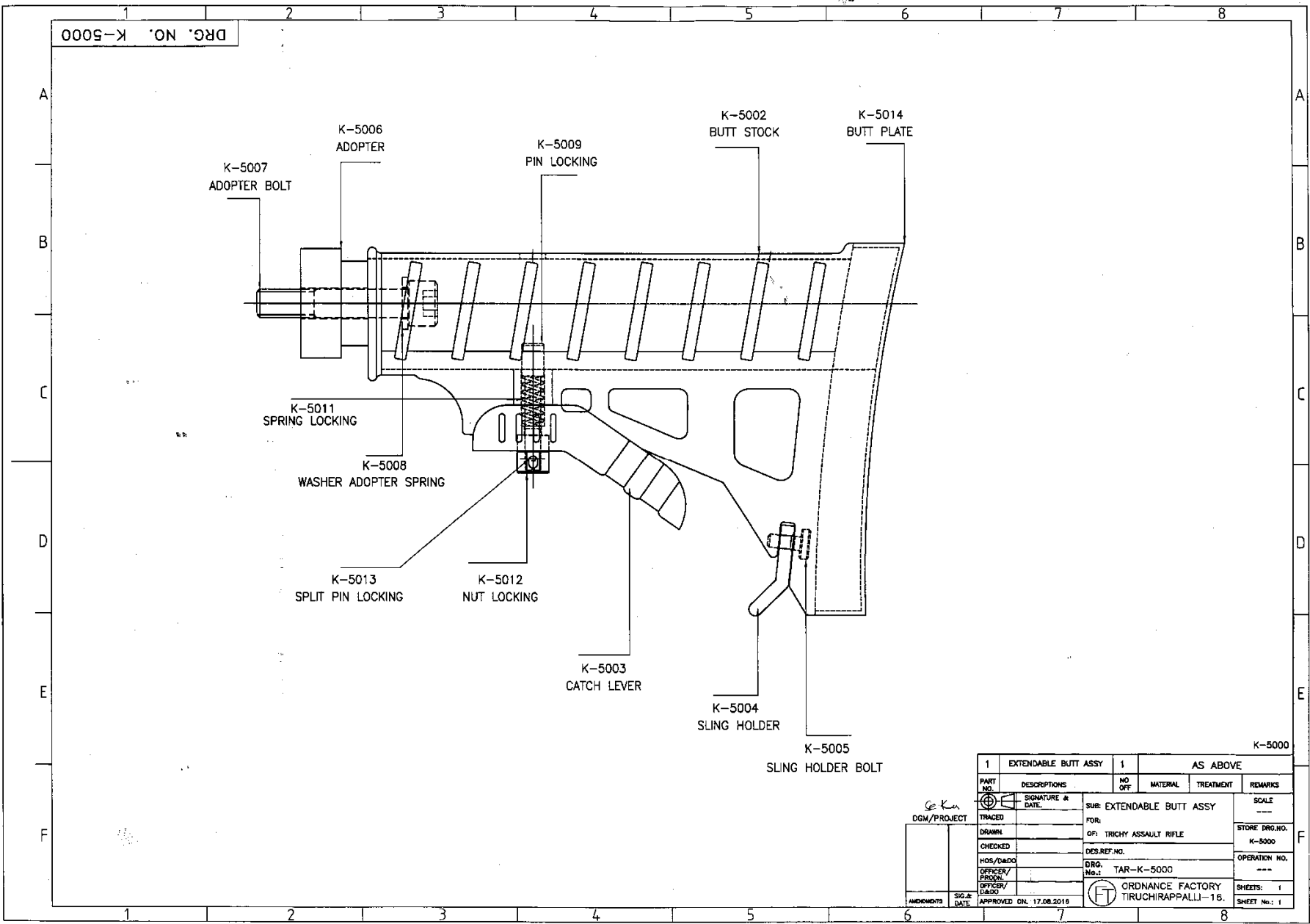

DRG. NO. K-5002

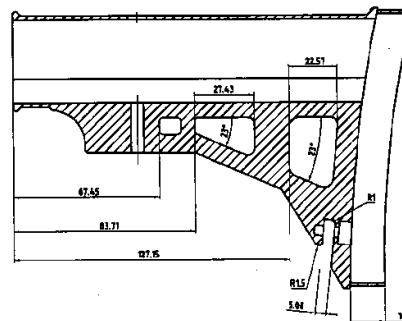
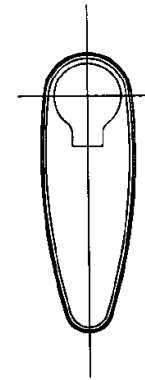
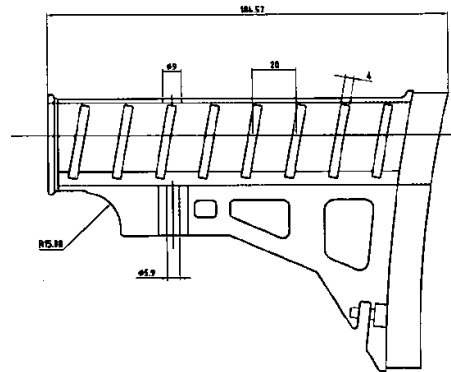
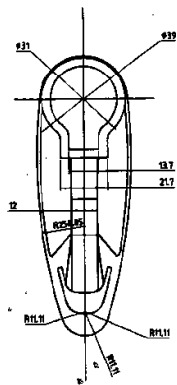

MATERIAL:

GLASS FIBRE REINFORCED POLYAMIDE (NYLON 6 OR 66)

MELTING POINT : NOT LESS THAN 200°C

COLOUR : MATT FINISH BLACK

K-5002

1	ADAPTOR	1	AS ABOVE		
PART NO.	DESCRIPTIONS	NO OFF	MATERIAL	TREATMENT	REMARKS
⊕	SIGNATURE & DATE.	SUB: BUTT STOCK FOR: EXTENDABLE BUTT ASSY OF: TRICHY ASSAULT RIFLE			SCALE ---
OGN/PROJECT	TRACED	DES. REF. NO.			STORE DRG NO. K-5002
	DRAWN	DRG. No.: TAR-K-5002			OPERATION NO. ---
	CHECKED	ORDNANCE FACTORY TRUCHIRAPPALLI-16.			SHEETS: 1
	HDS/D&DO OFFICER/ PRODN.	APPROVED ON. 17.08.2018			SHEET No.: 1
	OFFICER/ D&DO				
AMENDMENTS	SIG. & DATE				

DRG. NO. K-5003

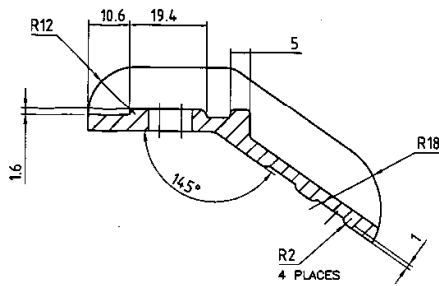
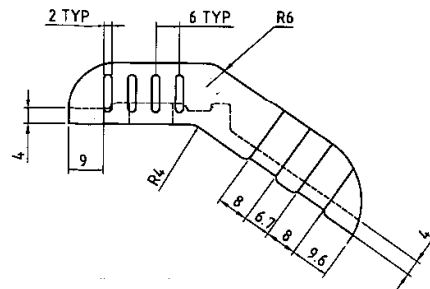
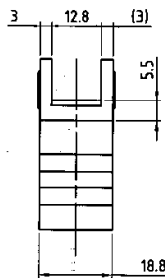
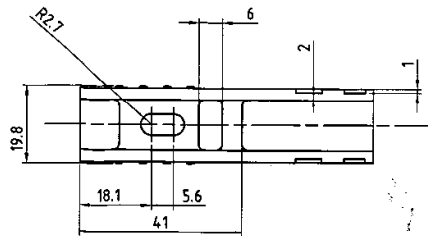

MATERIAL

ASTM B22M : AL 7075 T6

PROTECTIVE FINISH :

HARD ANODISING COATING.

COATING THICKNESS : 0.04 - 0.06MM

HARDNESS : 375-450 HV

K-5003

1		CATCH LEVER		1		AS ABOVE			
PART NO.	DESCRIPTIONS	NO OFF	MATERIAL	TREATMENT	REMARKS	SCALE			
TRACED	SIGNATURE & DATE	SUB: CATCH LEVER FOR: EXTENDABLE BUTT ASSY OF: TRICHY ASSAULT RIFLE				---			
DRAWN		DES. REF. NO.				STORE ORG. NO. K-5003			
CHECKED		DRG. No.:				OPERATION NO. ---			
HOS/D&DO		TAR-K-5003							
OFFICER/PROB.		ORDNANCE FACTORY TIRUCHIRAPPALLI-16.				SHEETS: 1			
OFFICER/D&DO		APPROVED ON. 17.08.2018				SHEET No.: 1			
AMENDMENTS	SG. & DATE								

7005-K ON DRG

DIMENSIONS ARE IN mm.  
 UNTOLERATED DIMS. AS PER IS : 2102 (MED)  
 MARK DRAWING No.

NOTE:- REMOVE ALL SHARP CORNERS

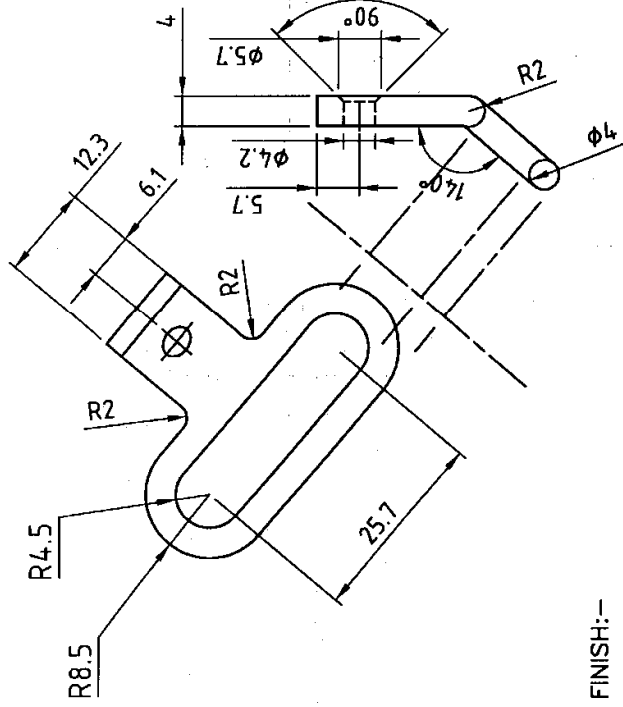

PROTECTIVE FINISH:-

PHOSPHATE TO SPECN. JSS 0465-01:1994,  
 CLASS II. (ACCELERATED), OIL FINISH.

BS:1449, Part 1:1983, GR SEC 2, CS-4/CS-14/CS-15

(OR) BS:1449, Part 1:1983, GR SEC 4, CS-12/CS-17/CS-20/CS-22/CS-30

HARDNESS: 250-325HV

K-5004

SLING HOLDER		NO OFF	MATERIAL	TREATMENT	REMARKS
PART NO.	DESCRIPTIONS	SUB: SLING HOLDER	FOR: EXTENDABLE BUTT	OF: TRICHY ASSAULT RIFLE	SCALE ---
	SIGNATURE & DATE				
TRACED					STORE DRG.NO. K-5004
DRAWN					OPERATION NO. ---
CHECKED					
HOS/D&DO					
OFFICER/ PRODN.					
OFFICER/ D&DO					
DESIGNER					
APPROVED ON. 17.08.2016					
AMENDMENTS	SIG. & DATE	ORDNANCE FACTORY TIRUCHIRAPPALLI-16.			
		SHEETS: 1			
		SHEET No.: 1			



DRG. NO. K-5006

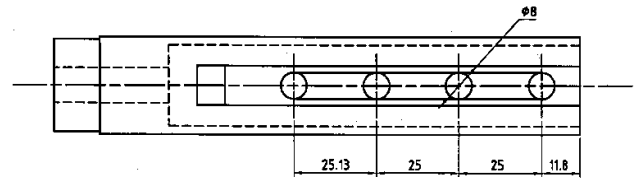
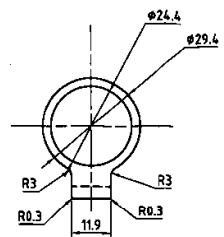
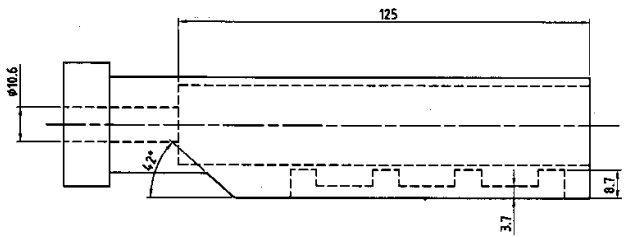
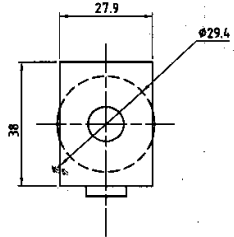
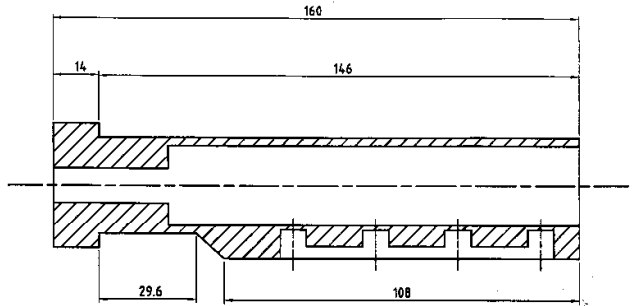

MATERIAL : ASTM B22M : AL 7075 T6

PROTECTIVE FINISH : HARD ANODISING COATING.  
COATING THICKNESS : 0.04 - 0.06MM

HARDNESS : 375-450 HV

K-5006

1	ADAPTOR	1	AS ABOVE		
PART NO.	DESCRIPTIONS	NO OFF	MATERIAL	TREATMENT	REMARKS
1	ADAPTOR				
	SUB: ADAPTOR				SCALE ---
	FOR: EXTENDABLE BUTT ASSY				STORE DRG.NO. K-5006
	OF: TRICHY ASSAULT RIFLE				OPERATION NO. ---
	DES. REF. NO.				
	DRG. No.: TAR-K-5006				SHEETS: 1
	ORDNANCE FACTORY TIRUCHIRAPPALLI-16.				SHEET No.: 1
AMENDMENTS	SIG & DATE	APPROVED ON. 17.08.2016			

DGM/PROJECT



005-K ON DRD

NOTE:- REMOVE ALL SHARP CORNERS

DIMENSIONS ARE IN mm.  
UNTOLERATED DIMS. AS PER IS : 2102 (MED)  
MARK DRAWING No.

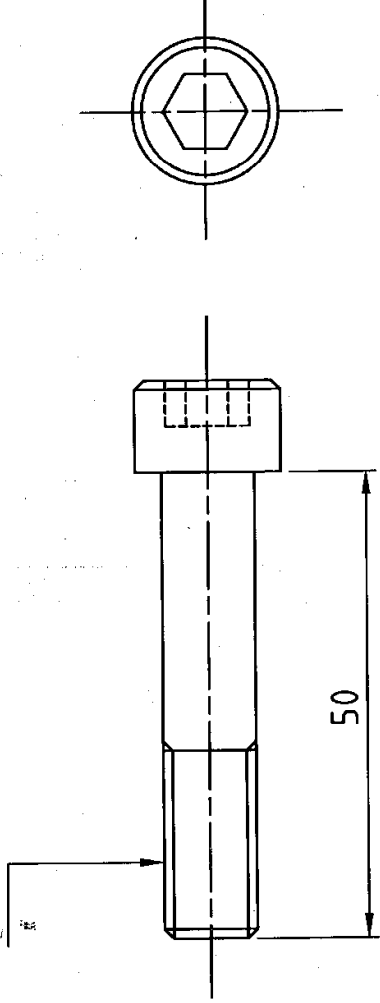

M10X1.5P



HEXAGON SOCKET HEAD CAP SCREWS

MATERIAL AS PER IS 2269:2006 STANDARD  
(STANDARD ITEM)

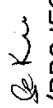
K-5007

PART NO.		ADAPTER BOLT		NO OFF		MATERIAL		TREATMENT		REMARKS			
DGM/PROJECT 				SIGNATURE & DATE.		SUB: ADAPTER BOLT							
		TRACED		DRAWN		CHECKED		HOS/D&DO		OFFICER/PRODN.		SCALE ---	
		OFFICER/D&DO		APPROVED ON. 17.08.2016		DES. REF. NO.		DRG. No.:		STORE DRG. NO.		OPERATION NO.	
						TAR-K-5007		ORDNANCE FACTORY TIRUCHIRAPPALLI-16.		K-5007		---	
												SHEETS: 1	
AMENDMENTS		SIG. & DATE								SHEET No.: 1			

8005-K 'ON DRD

PROVISIONAL

DIMENSIONS ARE IN mm.  
UNTOLERATED DIMNS. AS PER IS : 2102 (MED)  
MARK DRAWING No.

NOTE:- REMOVE ALL SHARP CORNERS

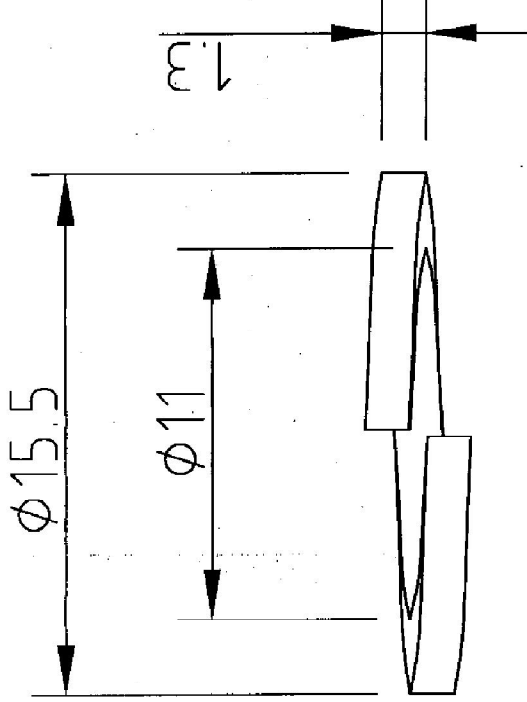

MATERIAL : STEEL BS:5770 Pt 2 1981 GR 080

ALT MATERIAL : STANDARD ITEM AVL FROM TRADE

TREATMENT :

ALT MATERIAL : STANDARD ITEM AVL FROM TRADE

K-5008

WASHER ADAPTER SPRING		NO OFF		MATERIAL		TREATMENT		REMARKS	
PART NO.	DESCRIPTIONS	SIGNATURE & DATE.		SUB: WASHER ADAPTER SPRING		SCALE		REMARKS	
				FOR: EXTENDABLE BUTT <td colspan="2">---</td> <td colspan="2">STORE DRG.NO.</td>		---		STORE DRG.NO.	
				OF: TRICHY ASSAULT RIFLE <td colspan="2">---</td> <td colspan="2">K-5008</td>		---		K-5008	
				DES. REF. NO. <td colspan="2">---</td> <td colspan="2">OPERATION NO.</td>		---		OPERATION NO.	
				DRG. No.:		---		---	
				ORDNANCE FACTORY		---		SHEETS: 1	
				TIRUCHIRAPPALLI-16.		---		SHEET No.: 1	
AMENDMENTS	SIG. & DATE	APPROVED ON.							

Ge K...  
DGM/PROJECT

SHEETS: 1  
SHEET No.: 1

4



6005-X 'ON DRD

DIMENSIONS ARE IN mm.  
 UNTOLERATED DIMNS. AS PER IS : 2102 (MED)  
 MARK DRAWING No.

NOTE:- REMOVE ALL SHARP CORNERS

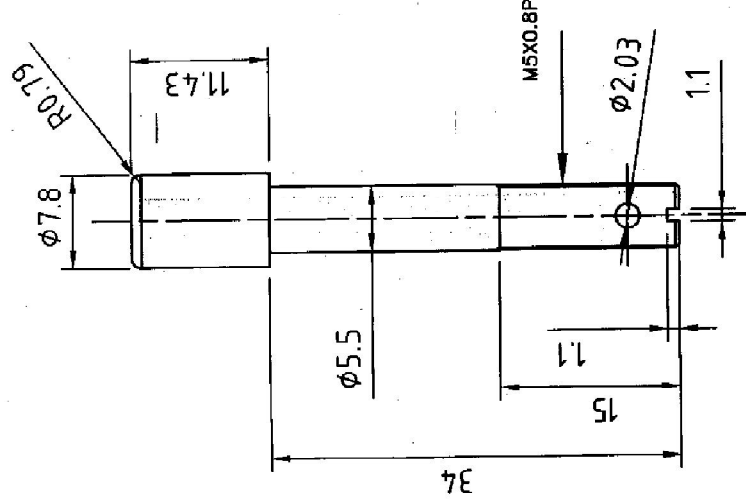

MATERIAL:-

STEEL BS:970 PART 1:1983 Gd.070 M20 (OR) En 3A, 3C

STEEL BS:970 PART 1:1983 Gd.080 M30 (OR) En 5

STEEL BS:970 PART 1:1983 Gd.080 M40 (OR) En 8

HARDNESS:- 300 TO 350 HV.

PROTECTIVE FINISH:- PHOSPHATE TO SPECN. JSS: 0465-01: 1994,

CLASS II.(ACCELERATED), OIL FINISH.

K-5009

PIN LOCKING		PIN LOCKING		PIN LOCKING		PIN LOCKING		PIN LOCKING	
PART NO.	DESCRIPTIONS	NO OFF	MATERIAL	TREATMENT	REMARKS	SCALE			
⊕	SIGNATURE & DATE.					---			
TRACED						STORE DRG.NO.			
DRAWN						K-5009			
CHECKED						OPERATION NO.			
HOS/D&DO						---			
OFFICER/PRODN.						DRG. No.: TAR-K-5009			
OFFICER/D&DO						OPERATION NO.			
						SHEETS: 1			
						SHEET No.: 1			
AMENDMENTS	SIG. & DATE	APPROVED ON. 17.08.2016		ORDNANCE FACTORY TIRUCHIRAPPALLI-16.		SHEET No.: 1			

DGM/PROJECT  
*[Signature]*

DRG. NO. K-5011

PROVISIONAL

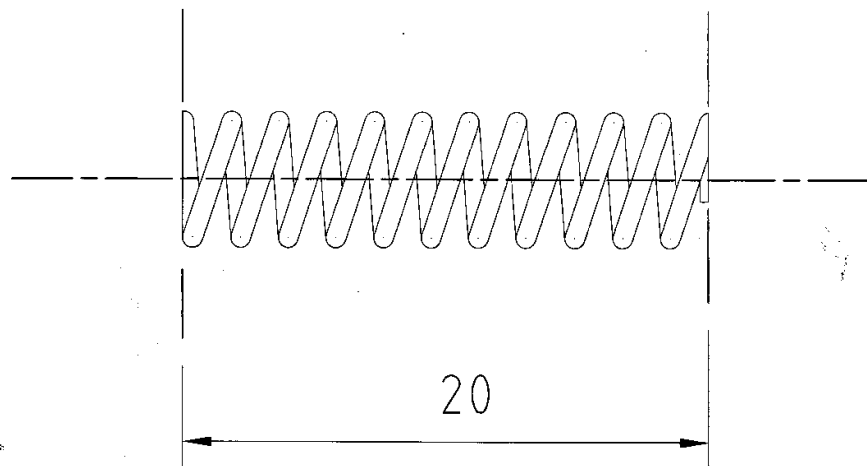

MATERIAL: - BS: 5216:1975 ND3  
OR  
IS: 4454, Pt.1-1981 Gr.3

PROTECTIVE FINISH: PHOSPHATE TO SPECN.:  
JSS: 0465:01-1988 CLASS-I, OIL FINISH

DIA OF WIRE - 1  
NO. OF EFFECTIVE COILS - 9  
  
OUTER DIA - 7.6  
INNER DIA - 5.6  
  
PITCH -

ONE COIL AT EACH END TO BE CLOSED IN GROUND  
SQUARE TO THE AXIS OF THE COIL LEAVING 3/4  
COIL AT EACH END NON-EFFECTIVE WOUND R.H. OR L.H.

K-5011

1		SPRING LOCKING		1		AS ABOVE	
PART NO.	DESCRIPTIONS	NO OFF	MATERIAL	TREATMENT	REMARKS		
	⊕ SIGNATURE & DATE.	SUB: SPRING LOCKING		SCALE		---	
TRACED		FOR:		STORE DRG. NO.		K-5011	
DRAWN		OF: TRICHY ASSAULT RIFLE		OPERATION NO.		---	
CHECKED		DES. REF. NO.		SHEETS:		1	
HOS/D&DO		DRG. No.: TAR-K-5011		SHEET No.:		1	
OFFICER/PROON.		ORDNANCE FACTORY TIRUCHIRAPPALLI-16.					
OFFICER/D&DO							
AMENDMENTS	SIG. & DATE	APPROVED ON.					

Z105-K 'ON' DRG

DIMENSIONS ARE IN mm.  
 UNTOLERATED DIMNS. AS PER IS : 2102 (MED)  
 MARK DRAWING No.

NOTE:- REMOVE ALL SHARP CORNERS

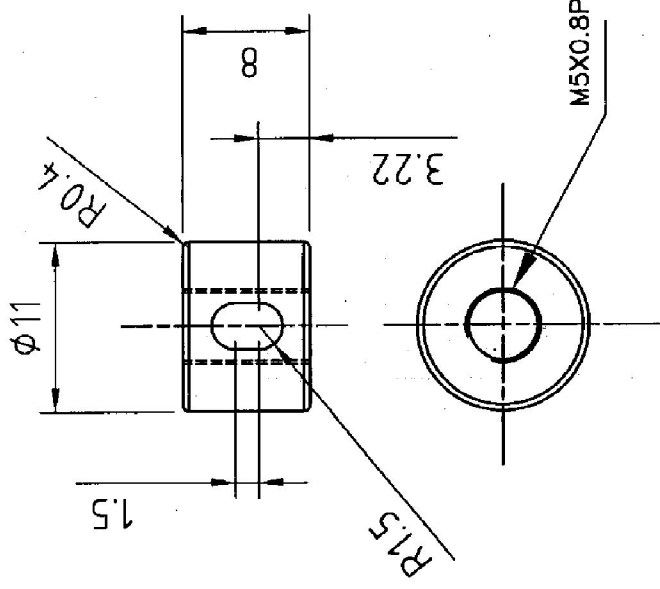

MATERIAL:-

- STEEL BS:970 PART 1:1983 Gd.070 M20 (OR) En 3A, 3C
- STEEL BS:970 PART 1:1983 Gd.080 M30 (OR) En 5
- STEEL BS:970 PART 1:1983 Gd.080 M40 (OR) En 8

HARDNESS:- 300 TO 350 HV.

PROTECTIVE FINISH:- PHOSPHATE TO SPECN. JSS: 0465-01: 1994,  
 CLASS II.(ACCELERATED), OIL FINISH.

K-5012

NUT LOCKING		NUT LOCKING		NUT LOCKING		NUT LOCKING		NUT LOCKING		NUT LOCKING	
PART NO.	DESCRIPTIONS	NO	OFF	MATERIAL	TREATMENT	REMARKS	SCALE	STORE DRG.NO.	OPERATION NO.	SHEETS:	SHEET No.:
	SIGNATURE & DATE.	SUB: NUT LOCKING									
TRACED		FOR: EXTENDABLE BUTT									
DRAWN		OF: TRICHY ASSAULT RIFLE									
CHECKED		DES.REF.NO.									
HOS/D&DO		DRG. No.:									
OFFICER/PRDGN.		TAR-K-5012									
OFFICER/D&DO		ORDNANCE FACTORY									
APPROVED ON. 17.08.2016		TIRUCHIRAPPALLI-16.									
AMENDMENTS	SIG.& DATE										

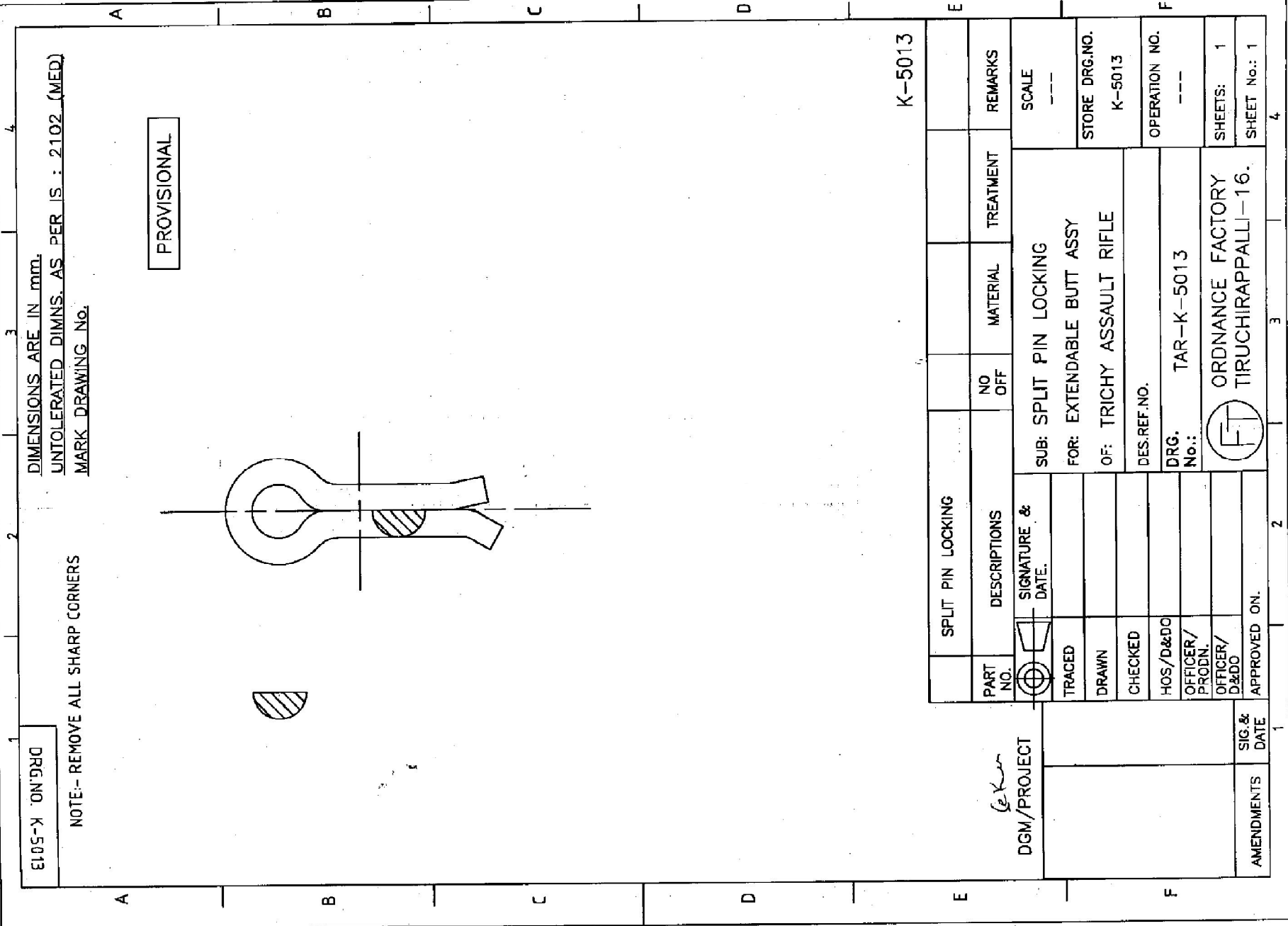

E105-K 'ON'DRD

NOTE:- REMOVE ALL SHARP CORNERS

DIMENSIONS ARE IN mm.  
 UNTOLERATED DIMNS. AS PER IS : 2102 (MED)  
 MARK DRAWING No.

PROVISIONAL

K-5013

SPLIT PIN LOCKING		SPLIT PIN LOCKING		SPLIT PIN LOCKING		SPLIT PIN LOCKING		
PART NO.	DESCRIPTIONS	NO OFF	MATERIAL	TREATMENT	REMARKS	SCALE		
	SIGNATURE & DATE.	SUB: SPLIT PIN LOCKING						---
TRACED		FOR: EXTENDABLE BUTT ASSY						---
DRAWN		OF: TRICHY ASSAULT RIFLE						---
CHECKED		DES. REF. NO.						---
HOS/D&DO		DRG. No.:						---
OFFICER/PRDGN.		TAR-K-5013						---
OFFICER/D&DO		ORDNANCE FACTORY						---
APPROVED ON.		TIRUCHIRAPPALLI-16.						---
AMENDMENTS	SIG. & DATE	SHEETS: 1						---
		SHEET No.: 1						---

DGM/PROJECT  
*(Signature)*

DRG. NO. K-5014

PROVISIONAL

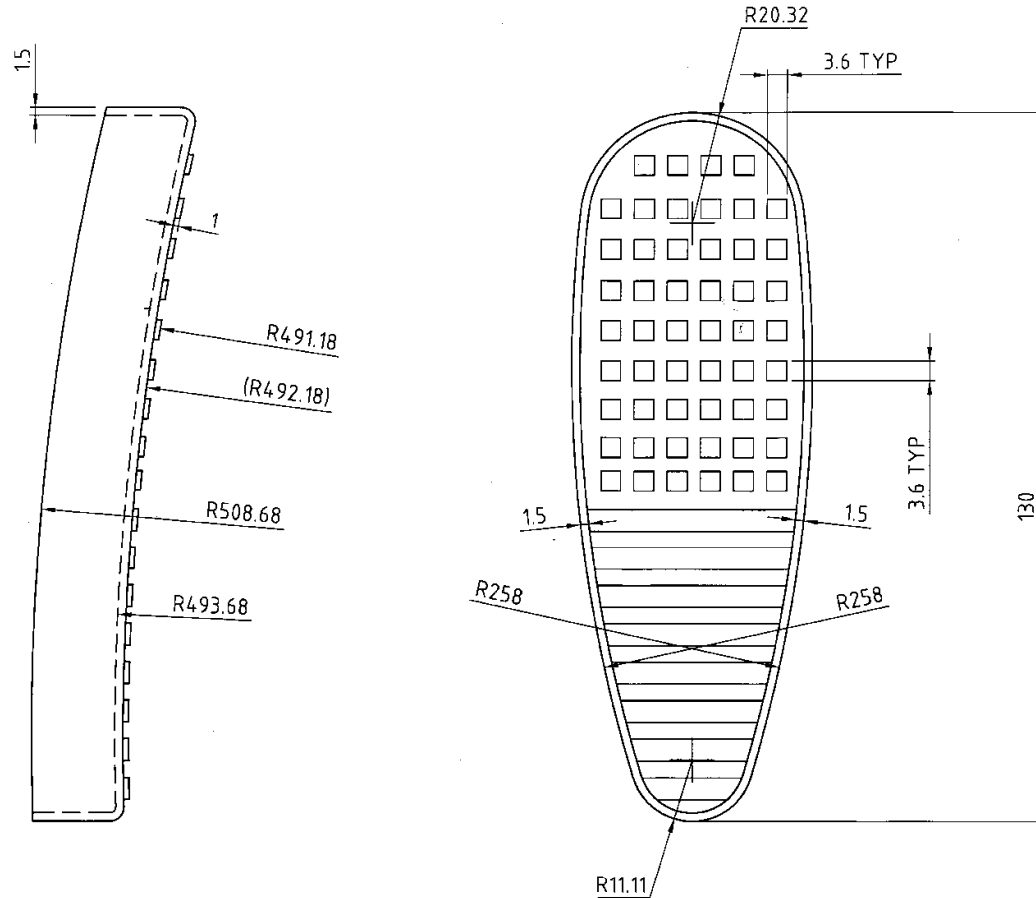

MATERIAL:

GLASS FIBRE REINFORCED POLYAMIDE (NYLON 6 OR 66)

MELTING POINT : NOT LESS THAN 200 C

COLOUR : MATT FINISH BLACK

K-5014

1	BUTT PLATE CAP	1	AS ABOVE		
PART NO.	DESCRIPTIONS	NO OFF	MATERIAL	TREATMENT	REMARKS
	SIGNATURE & DATE				SCALE
	TRACED				---
	DRAWN				STORE DRG. NO.
	CHECKED				K-5014
	HDS/DSDG				OPERATION NO.
	OFFICER/PRODR				---
	OFFICER/DSDG				
	APPROVED ON: 17.08.2016				SHEETS: 1
					SHEET No.: 1

SUB: BUTT PLATE CAP  
 FOR: EXTENDABLE BUTT ASSY  
 OF: TRICHY ASSAULT RIFLE  
 DES. REF. NO.  
 DRG. No.: TAR-K-5014  
 ORDNANCE FACTORY TIRUCHIRAPPALLI-16.