

प्रमाणित प्रतिलिपि CERTIFIED COPY OF
 ड्राइंग / लेआउट / गेज सिडबुल *HMM/MPM*
 DRG/LAYOUT/GAUGE SCHEDULE
 दिनांक / AT THIS DATE *13.06.17*
 सी डी डी / CDD
 राइफल फैक्टरी, ईशापुर
 RIFLE FACTORY, ISHAPUR

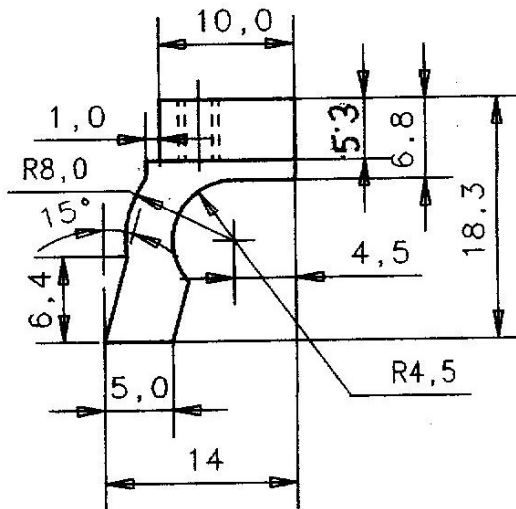

GENERAL TOLERANCE AS PER IS:2102 GRADE FINE

SURFACE FINISH: PHOSPHATED TO SPECN. JSS-0465-01 1988 CLASS II OIL FINISH

MATERIAL: STEEL IS:5517 Gd.55 Mn 75 / ALT MATERIAL En 9

HEAT TREATMENT: 300-350 VPN

ALT. MATL.: THROUGH MIM ROUTE

TITLE OF	OPERATION NO.	2016	NAME	DATE
		DGN.	N.M.KARMAKAR	16.02.16
		DRN.		
ORDNANCE FACTORY BOARD RIFLE FACTORY ISHAPUR		SCALE	CKD.	
			APPD.	
TRIGGER LOCKING BRACKET 12 BORE PUMP ACTION GUN		DRG No.		
		PAG-0049B		
		SHEET	OF	

REFERENCE GCP DRG No. 56-052/3

MIM