

5340-179455

ON DRG. CONVENTIONS CONFORM TO JSG : 0104
 DIMNS. ARE IN mm. GEN. TOL. 'MEDIUM' TO IS : 2102

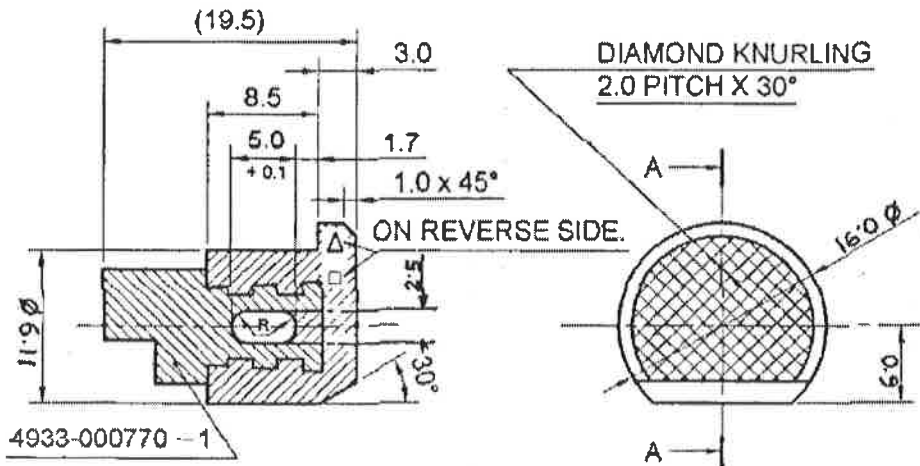

SECTION - A A

NOTES :-

- COLOUR OF RAW MATERIAL :- IS : 5-2007 No.695, DARK BLUE GREY.
- ALT. COLOUR :- MRF SHADE CARD NO. BLACK - 600
- COATING :-VAPOCURE COATING IN DARK BLUE GREY COLOUR
- CODE 695 TO SPECIFICATION IS : 5 : 2007. OR MRF SHADE No.
- BLACK - 600 WITH MATT FINISH.
- TEST :- NO CRACKS AND BLEMISHES TO BE OBSERVED ON MOULDED PART
- WHEN INSPECTED VISUALLY AND TESTED BY DROPPING ITEM FROM 1m. HEIGHT ON
- HARD CONCRETE BED WHEN ASSEMBLED WITH WEAPON IN FOLLOWING CONDITIONS.
 - a) AMBIENT TEMPERATURE
 - b) KEPT AT - 50°C FOR 12 HRS.
 - c) KEPT AT + 60°C FOR 12 HRS.
- PHYSICAL PROPERTIES TO CONFORM
- TO MATERIAL AS PER DRAFT SPECN.
- ADDITION OF COLOUR PIGMENT NOT
- PERMITTED.

MARKING NOTE :-

- MANUFACTURER'S CODE (ON MOULDING)
- Yr. OF Mfg

04-03-11	26518-SA	D.S.CAT.NO. ADDED			
29-11-10	26552-SA	IN ASSY. 1005-560625 WAS CQA(SA)SK-763			
17-11-09	26474-SA	DRG. PROV. SEALED.			
DATE	AUTHY	BRIEF RECORD	ZONE	I/C,D.O.	G.O.
SEALED :- PROV. D.C. No. 26474-SA. DT. 17-11-09					SIGN
DRN. J GOSWAMI	CHD. SKP	TRD.	COMP.	AHSP CQA(SA)ICHAPUR	
SCALE:- 2:1		EST. MASS		ASSY 1005-560625	
DT. 17-11-09	I/C,D.O	APPROVED	FOR CQA(SA)		
MATERIAL :- PHENOLIC RESIN, DARK BLUE GREY COLOUR				DGNR'S REF. 1005-560091	
CODE 695 TO SPECN. IS : 5 : 2007.				PART NO.	
H.T/HARDNESS:-		AS STATED		DRG.NO. CQA(SA)SK-982	
PROTECTIVE FNISH:-		AS STATED		D.S.CAT. NO. 5340-179455	
NOMENCLATURE:- PLUNGER H O D (MOULDING)					