



: "HEVFAC"  
: 044-26843534  
E-mail: steelhvf@ord.gov.in



HEAVY VEHICLES FACTORY  
AVADI, CHENNAI - 600 054,  
A unit of AVNL,  
MINISTRY OF DEFENCE

No. 6005/HVF/TA/STEEL/AVR

Date: 25/04/2022

**TO WHOMSOEVER IT MAY BE CONCERNED**

Sub: CORRIGENDUM FOR ADVANCE VENDOR REGISTRATION (AVR) REGARDING

In continuation to the AVR issued for the subject item, the following terms and conditions are added as corrigendum:

1. Die & Punches will be provided by HVF after submission of necessary Bank guarantee.  
The firm has to collect Dies & Punches from HVF by arranging its own transportation.
2. Suitable clamping arrangements for fixing of Die/Punch on to the press and ejection mechanism are to be done by the vendor separately without modifying the Dies & Punches.
3. Modifications on Dies or Punches are not allowed since die/punch is HVF's property.
4. Firm will be responsible for any kind of damage caused to the Die & Punch and in case of any, firm will have to replace the same at their cost.
5. Firm should have suitable press of capacity to carry out the job. The capacity of press mentioned in VQC is for reference only.
6. On successful completion of supplies, the firm has to return the Dies and Punches in good condition at firm's cost.

  
(S KADIRVEL)  
Jt. GENERAL MANAGER  
For GENERAL MANAGER

N.K.S.R

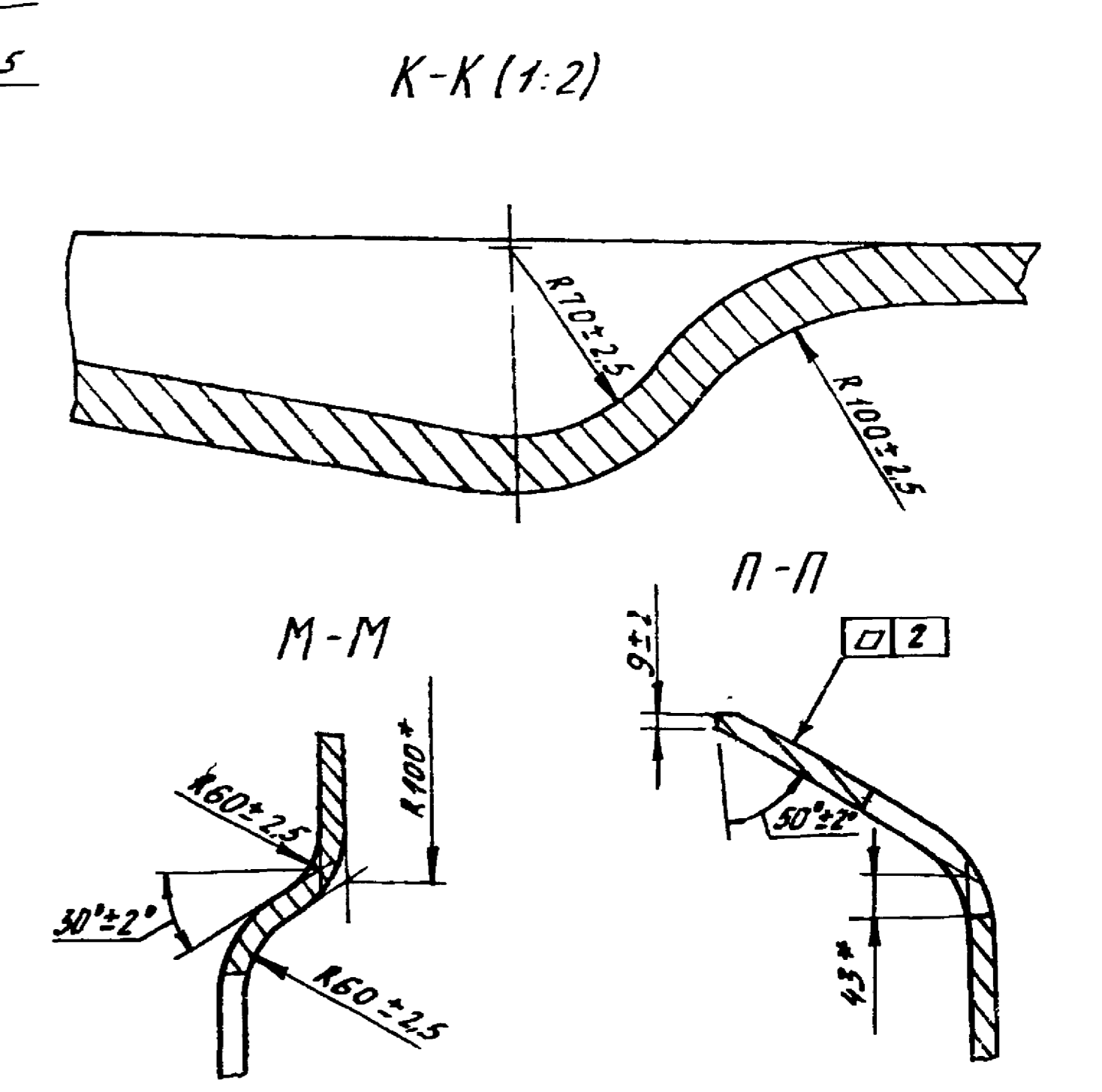
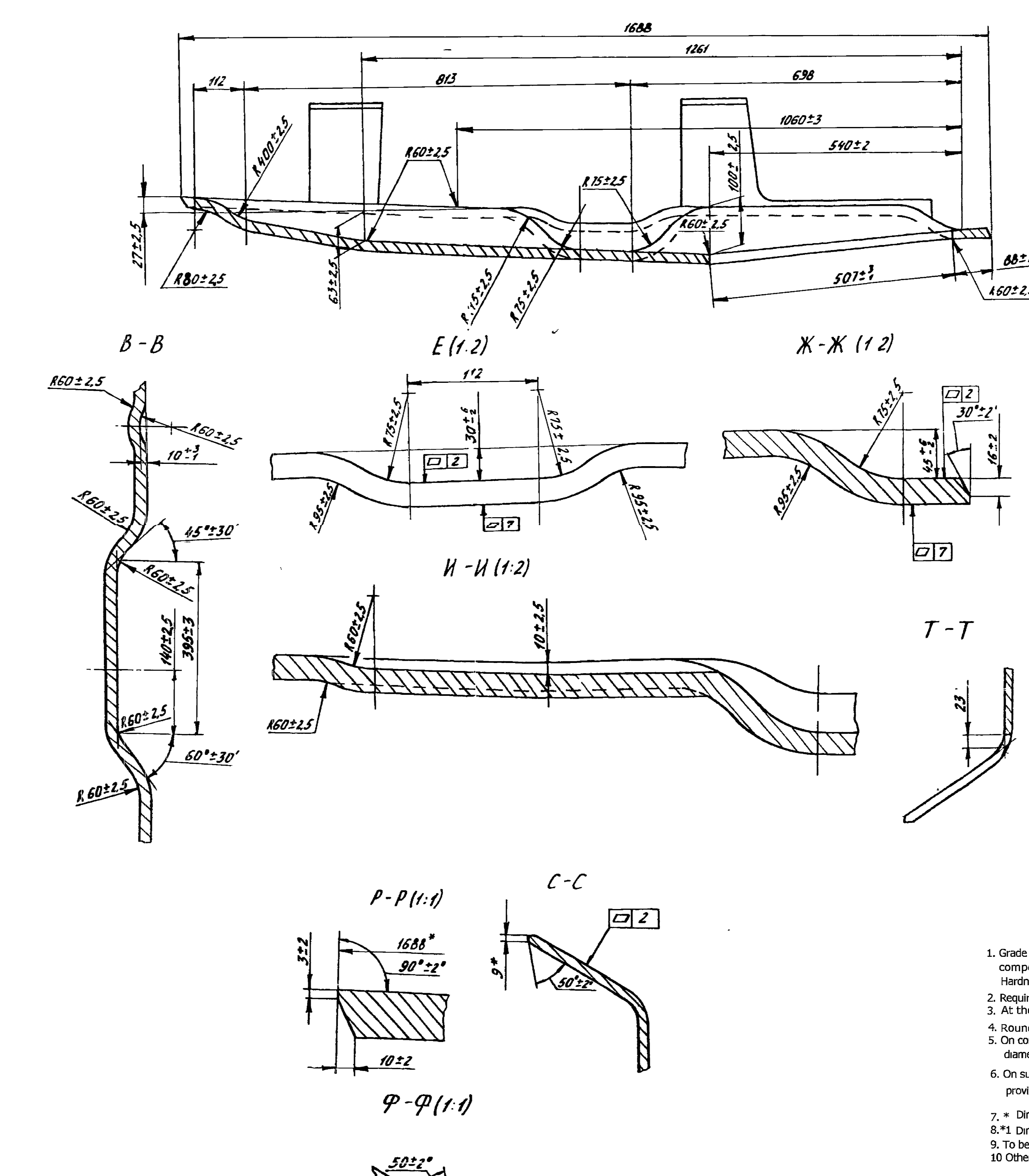
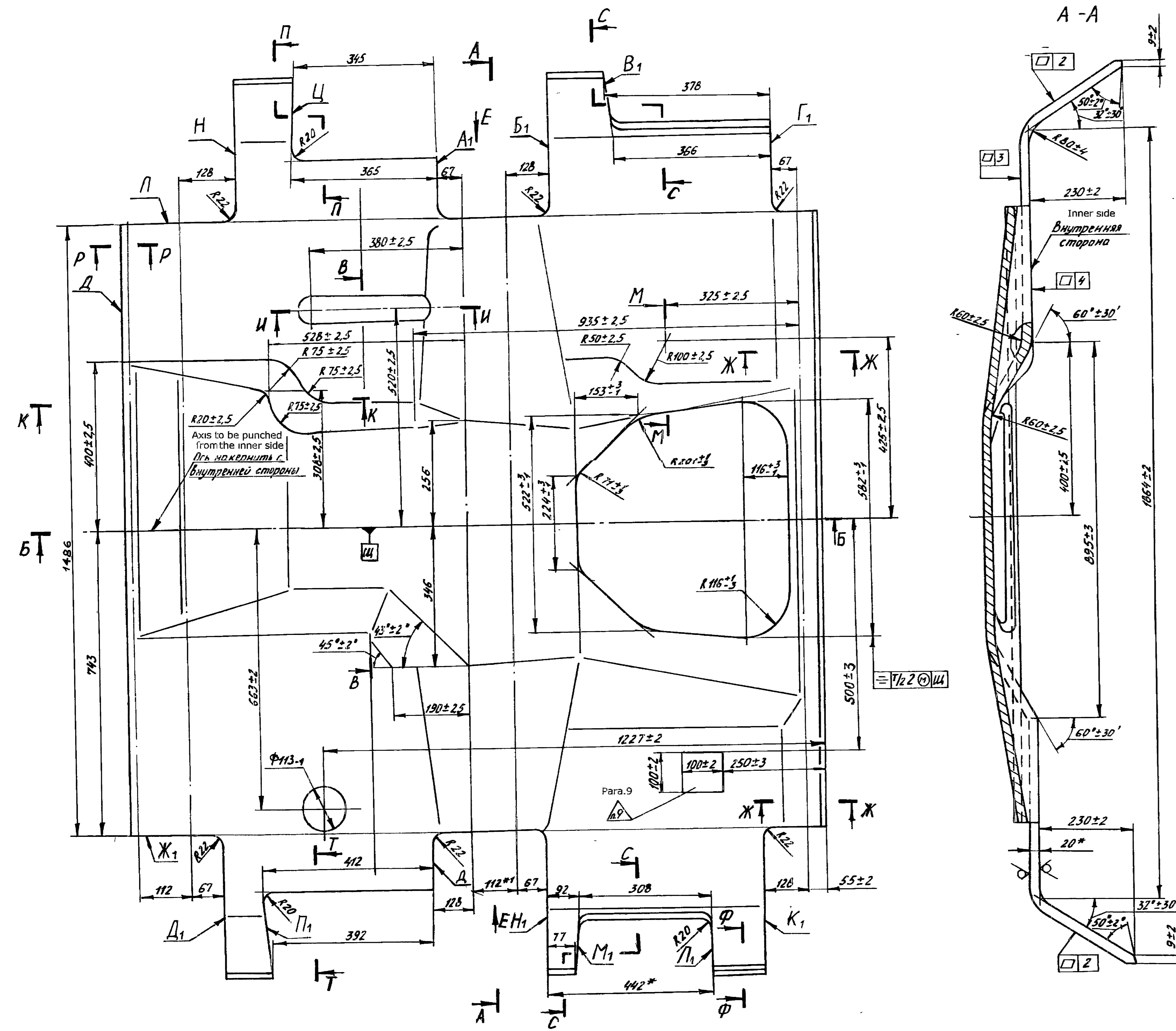

- 1 Марка стали, термообработка, способ приемки и испытаний согласно ведомости на детали из спец. стали
- 2 Требования к качеству газорезных кромок согласно ГОСТ3-4301-89
- 3 В местахгиба допускается утончение металла не более 17 мм
- 4 Допускается скругление углов R 5<sup>mm</sup>
- 5 На поверхности детали допускаются следы от технологических керн глубиной не более 0<sup>3</sup> мм, диаметром не более 6<sup>1</sup> мм
- 6 На поверхностях Д, Л, Н, Ц, А, Б, В, Г, Д, Ж, К, Л, М, Н, П, П1 предусмотреть технологический припуск
- 7 \*Размеры для справок
- 8 \*Размеры обеспечить инструментом
- 9 Клеить с внутренней стороны
- 10 Остальные требования по 520.TY1

1. Grade of steel, heat treatment method of acceptance and testing should comply with the list for components made out of special steel. Hardness - medium.
2. Requirement for quality of gas cutting faces should comply with OCTB3-4301-89.
3. At the place of bending thinning of metal may not exceed 17 mm.
4. Rounding-off radii are allowed by 5<sup>mm</sup>
5. On component surface traces from technological punch may not exceed the depth by 0<sup>3</sup> mm, diameter by not exceed 6<sup>1</sup> mm
6. On surface Д, Л, Н, Ц, А, Б, В, Г, Д, Ж, К, Л, М, Н, П, П1 technological allowance are to be provided.
7. \* Dimension for reference.
- 8.\*1 Dimension are to be ensured by tool.
9. To be stamped from inner side.
- 10 Other requirements as per 520.TY1.

356  
SUPPLY CODE  
U-01-1-2  
D 90057  
F-57  
63  
SI 18 A1x3

PILOT SAMPLE SHOULD BE APPROVED BY A H S P BEFORE BULK PRODUCTION.  
EST. WT. (kg) 443  
TO BE STAMPED OR MARKED WHERE INDICATED THIS # ( LETTERS)

|               |                  |   |         |                         |                  |  |                           |                |      |                      |
|---------------|------------------|---|---------|-------------------------|------------------|--|---------------------------|----------------|------|----------------------|
| DRN           | CHD              | APPD  | DATE    | SCALE                   | DIMENSIONS IN mm | TOLERANCE ON DIMS UNLESS OTHERWISE STATED IS .102-69 | ALL THREADS TO CONFORM TO | ISSUE          | DATE | NATURE OF AMENDMENTS |
| 172.01.009-16 | 8.10.04          | Chausat   | 21.7.04 | 1:5                     |                  |  |                           |                |      |                      |
| MATERIAL:-    | USED ON:-        | CONTROLLERATE OF QUALITY ASSURANCE (HEAVY VEHICLES) AVADI |         | TITLE:-                 |                  | D S CAT NUMBER                                       |                           | DRAWING NUMBER |      |                      |
| SPECIAL STEEL | 172.01.198cb-7Cb |   |         | HULL BOTTEM FRONT PLATE |                  |  |                           | 172.01.009-16  |      |                      |