

DRAWING CONVENTIONS CONFORM TO IS: 696
DIMNS ARE IN m.m. UNLESS OTHERWISE STATED

NOTES :- 1. ALL SHARP EDGES AND BURRS ARE TO BE REMOVED.
2. DIMENSIONS ARE APPLICABLE ON ASSY (DET No. 14)
AFTER SEAM WELDING.

DRG. No. ARDE 2139
DET. No. 15 SHTS. 1 SHTS. 1

GEN. TOL. MEDIUM/COURSE/FINE CLASS TO IS: 2102

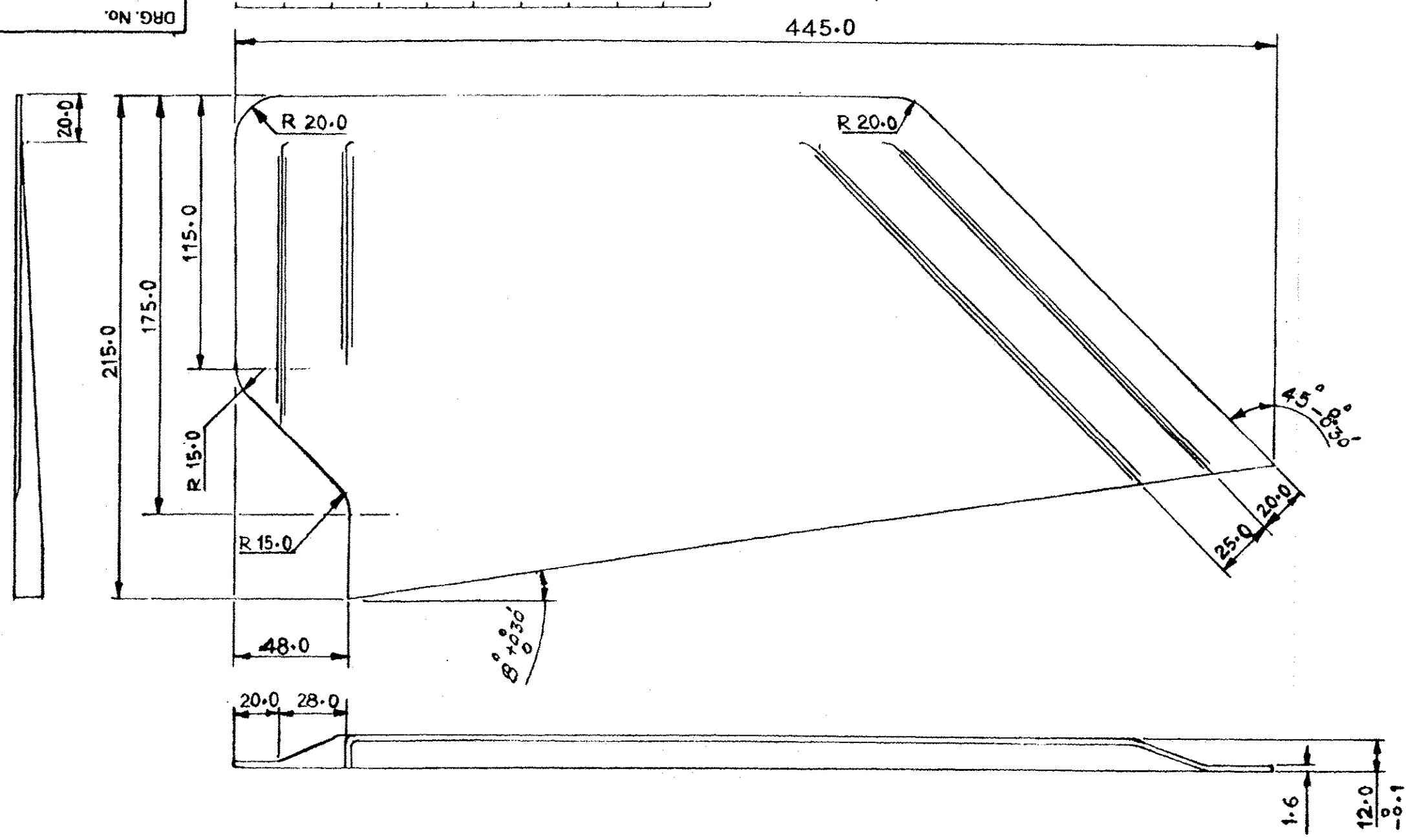

DRN. SKK		CHD. <i>g</i>		TRD.		COMP.		ASSY DRG. ARDE 2139/14	
CD		PASSED		SCALE: 1:2		EST MASS:		DESIGN AUTHORITY	
APPROVED		<i>(R PERUMAL)</i> SC'D FOR DIRECTOR		DATE: 3-5-90		GAUGE SCHD:		ARDE PUNE - 411021	
1		18.10.17		RCMA(AA)1434/3/11.9.17		DRG. AMENDED VIDE AL. NO. 21/2017		MATERIAL	
R. NO.		DATE:		AUTHORITY		BRIEF RECORD		ZONE	
DRG SEALED (PROV)		<i>Arundhan. Arundhan</i>		CRE (AA)		PROTECTIVE FINISH: PHOSPHATED TO IS: 3618 CLASS 'B'		MATERIAL: STEEL TO IS: 513:2008 DESIGNATION CR 2	

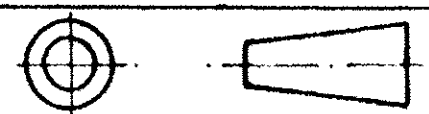

TITLE:

FIN (LEFT)

DRG. No. ARDE 2139		
DET. No. 15	SHTS.	SHT.No.
PART No.		
D. S. CAT. No.		
A.H.SP.		

8

7

6

5

4

3

2

1

PART No. ARDE 2139
 DET No. 16 SHTS. 16
 DRG. No. ARDE 2139

DRAWING CONVENTIONS CONFORM TO IS :
 DIMNS ARE IN m.m. UNLESS OTHERWISE STATED
 GEN. TOL. MEDIUM/COURSE/FINE CLASS TO IS : 2102

NOTES :- 1. ALL SHARP EDGES AND BURRS ARE TO BE REMOVED.
 2. DIMENSIONS ARE APPLICABLE ON ASSY (DET No. 14) AFTER SEAM WELDING.

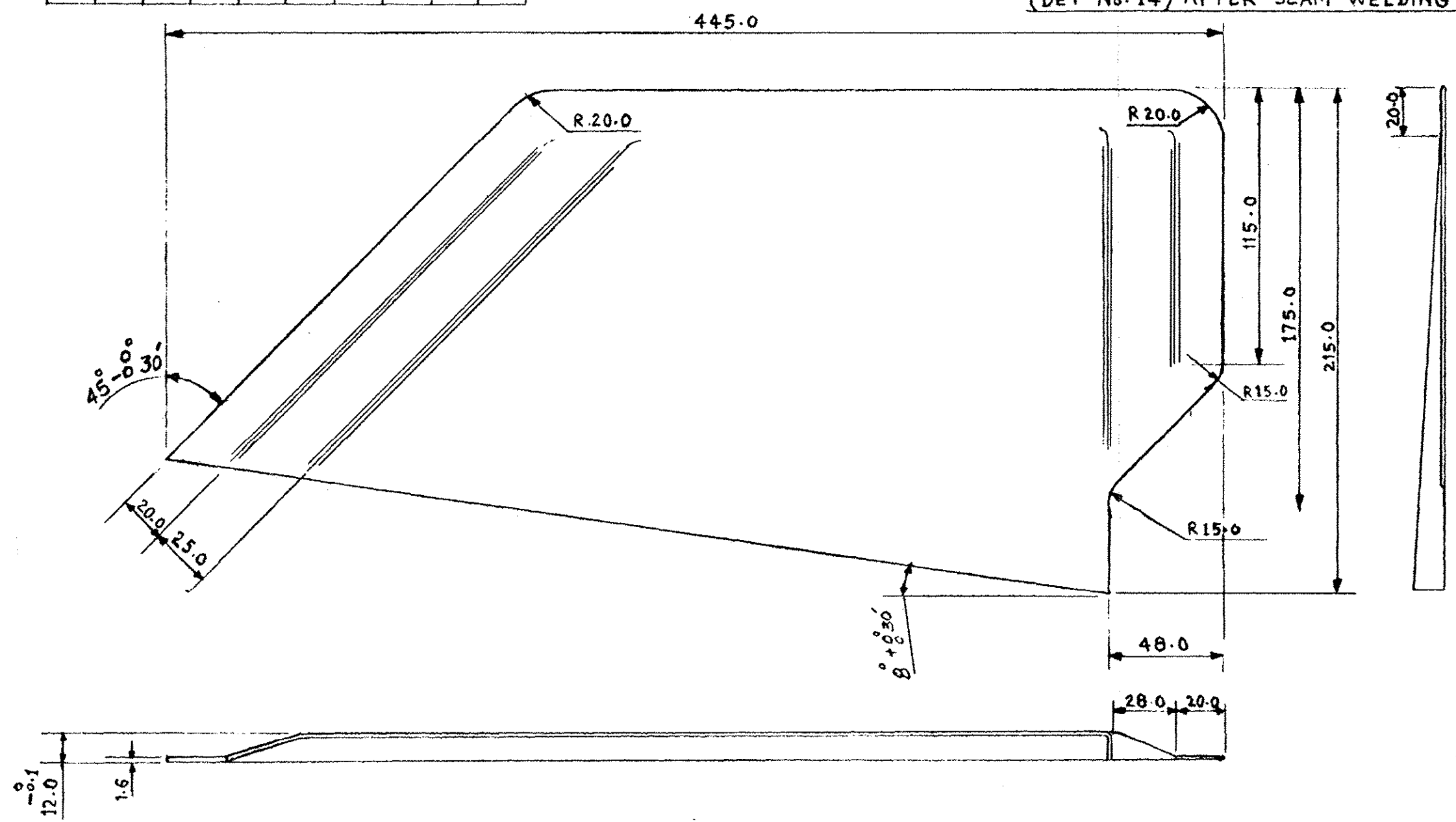

						DRN. B K D	CHD. G	TRD.	COMP.	ASSY DRG. ARDE 2139/14
						CD	PASSED	SCALE: 1:2		DESIGN AUTHORITY
						APPROVED		EST MASS:		ARDE PUNE - 411021
						(R PERUMAL) SC'D FOR DIRECTOR		GAUGE SCHD:		
1	18.10.17	RCMA(AA)1434/3/11.9.17	DRG. AMENDED VIDE AL. NO. 21/2017	MATL.	@num			DATE: 4-5-90		
R. NO.	DATE:	AUTHORITY	BRIEF RECORD	ZONE	CD	GO	MATL: STEEL TO IS:513:2008 DESIGNATION CR 2			
					SIGN					
							PROTECTIVE FINISH: PHOSPHATED TO IS:3618 CLASS 'B'			

TITLE: FIN (RIGHT)
 16-10-92

DRG. No. ARDE 2139
 DET. No. 16 SHTS. SHT. No.
 PART No.
 D. S. CAT. No.
 A.H.S.P.

18

LIST OF COMPONENT

ITEM No.	NOMENCLATURE	No. OFF	MATL.	DRG. No.	DET. No.	PART No.
1	FIN (LEFT)	1		ARDE 2139	15	
2	FIN (RIGHT)	1		ARDE 2139	16	

DRG. No. ARDE 2139		DET. No. 14		SHTS.	
PART No.		DRG. CONVENTIONS CONFORM TO IS: 696			
DIM ARE IN M.M.					

SEAM WELDING TO
IS: 813-1986

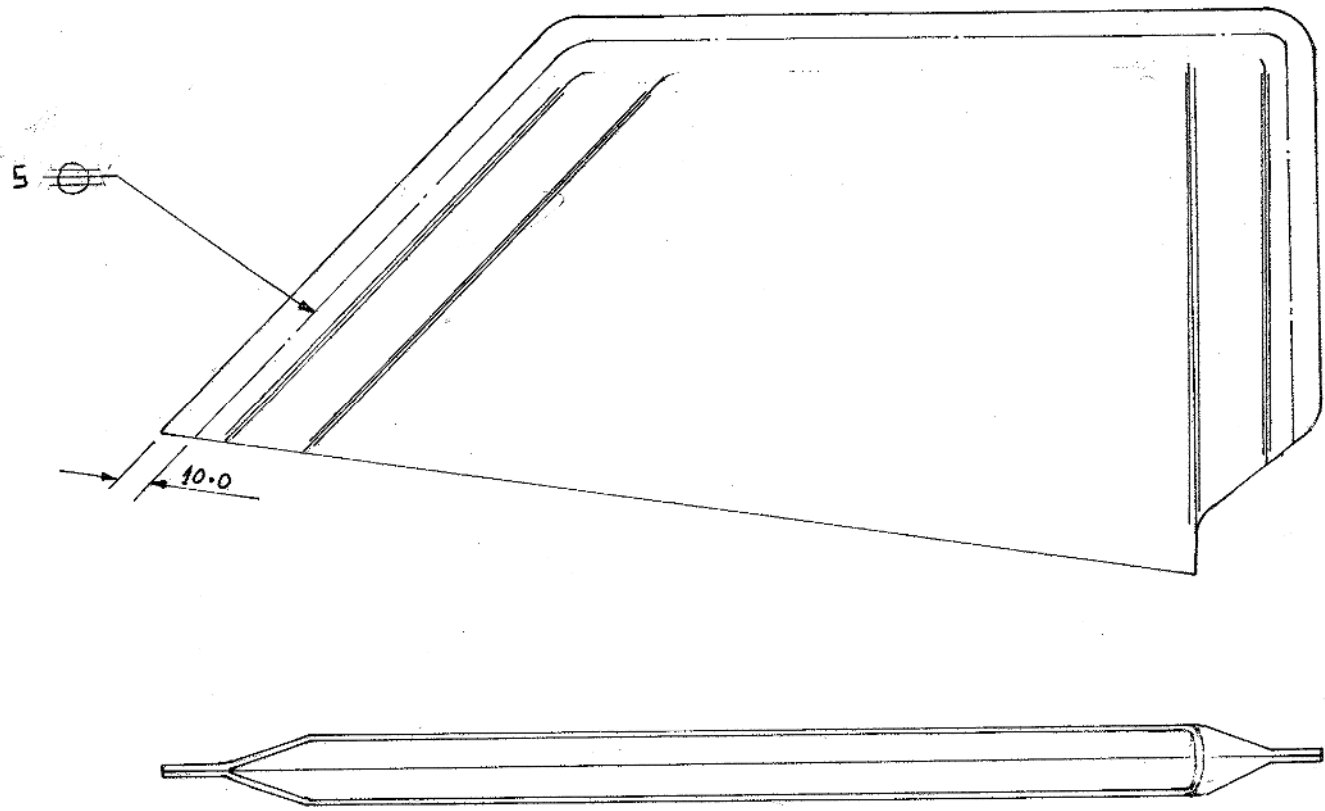

DRN	SKK	CD	TRD	COMP	ASSY DRG. ARDE 2139/2
CD		PASSED	SCALE - 1:2		DESIGN AUTHORITY
			EST WEIGHT		ARDE PUNE 21
			GAUGE SCHD		
			DATE: 11.5.90		
1	11.1.95	DRG. AMENDED VIDE AL. No. 2/95			
R No.	DATE	AUTHORITY	BRIEF RECORD	ZONE	CD GO SIGN
				CRE(AA)	
				16.10.92	
				PROTECTIVE FINISH -	

FIN ASSY

DRG. No. ARDE 2139		
DET No. 14	SHTS.	SHT. No.
PART No.		
D.S. CAT. No.		
AHSP		