

DRG. INDIANISED BASED ON RUSSIAN ORIGINAL ISSUE - NIL  
INTRODUCED VIDE NOTIFICATION No.18817-24-08

DRAWING NUMBER  
**188.41.007**

SHEET No. 1 OF 1

$\sqrt{Rz80}$  (✓)

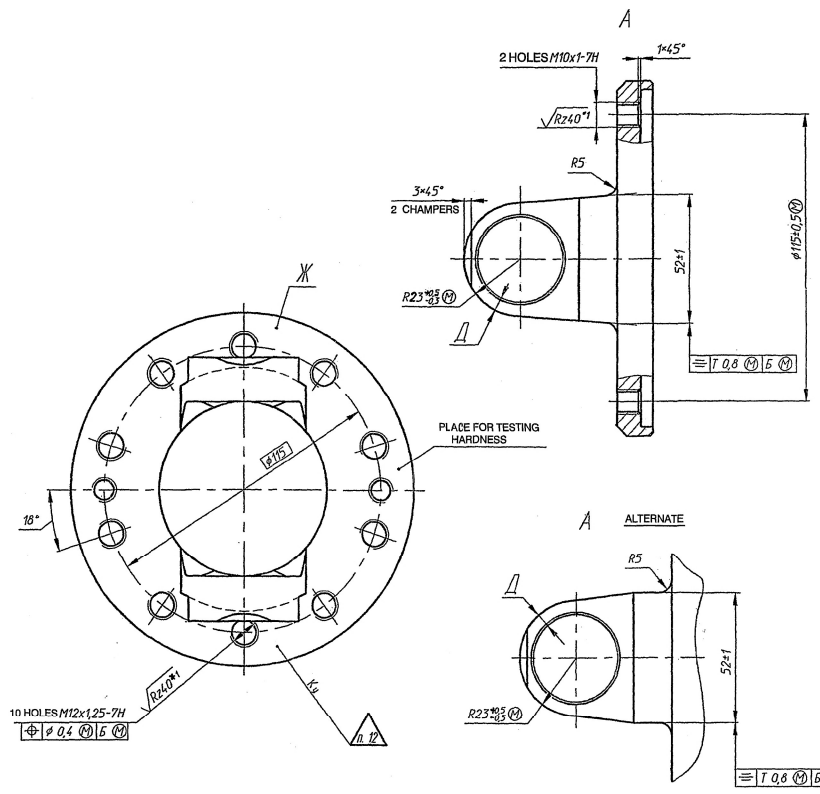
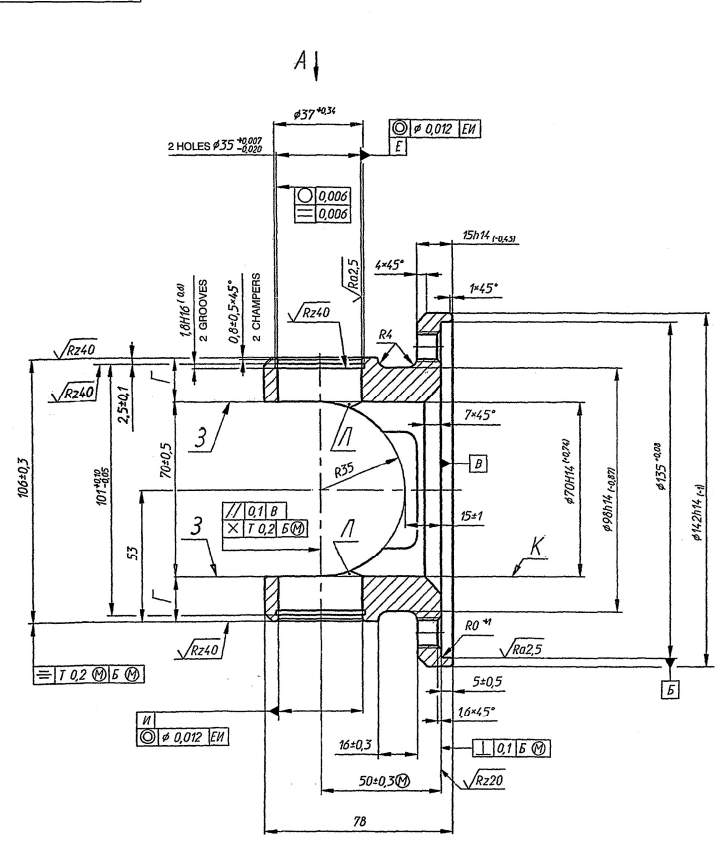

1. 285.....341 BHN.
2. Difference in dimensions Γ not more than 0.5mm, error of measurement ± 0.1mm.
3. Dimension D not less than 5mm, error of measurement ± 0.1mm.
4. \* Dimensions for reference.
5. \*1 Ensure surface finish with tool.
6. On surface XK, projections in height 0<sup>+0.5</sup> mm are allowed.
7. When making hole K marking of tool is allowed on surface 3.
8. On surfaces E and I, notch due to withdrawal of tool is allowed in depth 0<sup>+0.2</sup> mm and width 0<sup>+0.2</sup> mm.
9. While making E and I on surface JI, step in depth 0<sup>+0.5</sup> mm towards increasing diameter is allowed.
10. It is allowed, instead of roundness tolerance and tolerance of longitudinal cross-section to check tolerances of non-stability of diameter in transverse and longitudinal cross-sections as per GOST 3325-85.
11. Coating: Chemical Phosphating . Oxidizing. Oil finish. Absence of coating in holes E and I are allowed.
12. Stamp.
13. Other requirements as per 520.TY1.

356  
SUPPLY CODE  
U-01  
D-90057  
F-78  
80A

PILOT SAMPLE SHOULD BE APPROVED BY A H S P BEFORE BULK PRODUCTION.

|                                                                                                                                                    |                                                           |
|----------------------------------------------------------------------------------------------------------------------------------------------------|-----------------------------------------------------------|
| EST. WT (kg)                                                                                                                                       | TO BE STAMPED OR MARKED WHERE INDICATED THUS # ( LETTERS) |
| 1.4                                                                                                                                                |                                                           |
| ALL SHARP EDGES AND CORNERS TO BE REMOVED UNLESS OTHERWISE STATED MACHINED CORNERS TO HAVE R OUT-SIDE R INSIDE EQUIVALENT CHAMFERS ARE PERMISSIBLE |                                                           |

|                                                          |           |                                                     |                          |
|----------------------------------------------------------|-----------|-----------------------------------------------------|--------------------------|
| DRN                                                      | APPROVED  | MATERIAL: STEEL 38XC                                | USED ON:- 188.41.005cbCb |
| CHD                                                      | APPROVED  | GOST 4543-71                                        |                          |
| APPD                                                     | APPROVED  | CONTROLLERATE OF QUALITY ASSURANCE (HEAVY VEHICLES) |                          |
| DATE                                                     | 27.7.2010 | AVADI                                               |                          |
| DIMENSIONS IN mm                                         |           | TITLE:-                                             |                          |
| SCALE:- 1:1                                              |           |                                                     |                          |
| TOLERANCE ON DIMNS UNLESS OTHERWISE STATED IS : 2102.-09 |           |                                                     |                          |
| ALL THREADS TO CONFORM TO IS : 4218, PART-4.             |           | D S CAT NUMBER                                      | DRAWING NUMBER           |
| ISSUE                                                    | DATE      | NATURE OF AMENDMENTS                                | 188.41.007               |

SIZE A3x3