

FOLLOWING TO BE STENCIL WITH LETTER HEIGHT 25-30mm
 TO, G.M., O.F. KHAMARIA,
 FROM, Sy. G.M. O.F. AMBAJHARI, NAGPUR 76.2mm/C.C., LOT No.

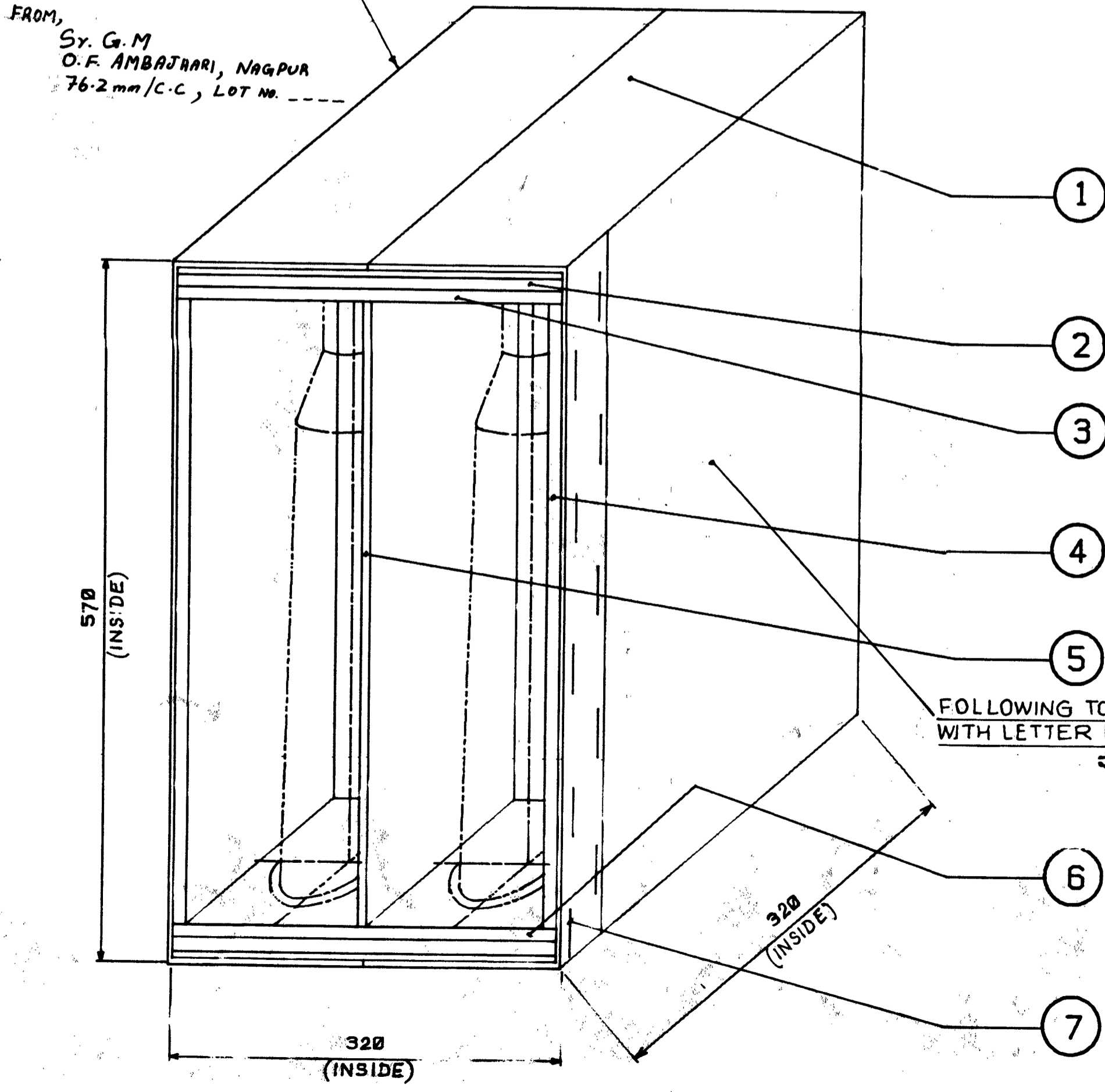

FOLLOWING TO BE STENCIL WITH LETTER HEIGHT 25-30mm
 सेवा में, महाप्रबंधक ऑ.फे. खमरिया द्वारा, वरिष्ठ महाप्रबंधक ऑ.फे. अम्बाजरी, नागपुर 76.2 एम.एम/सी.सी. लॉट नं.

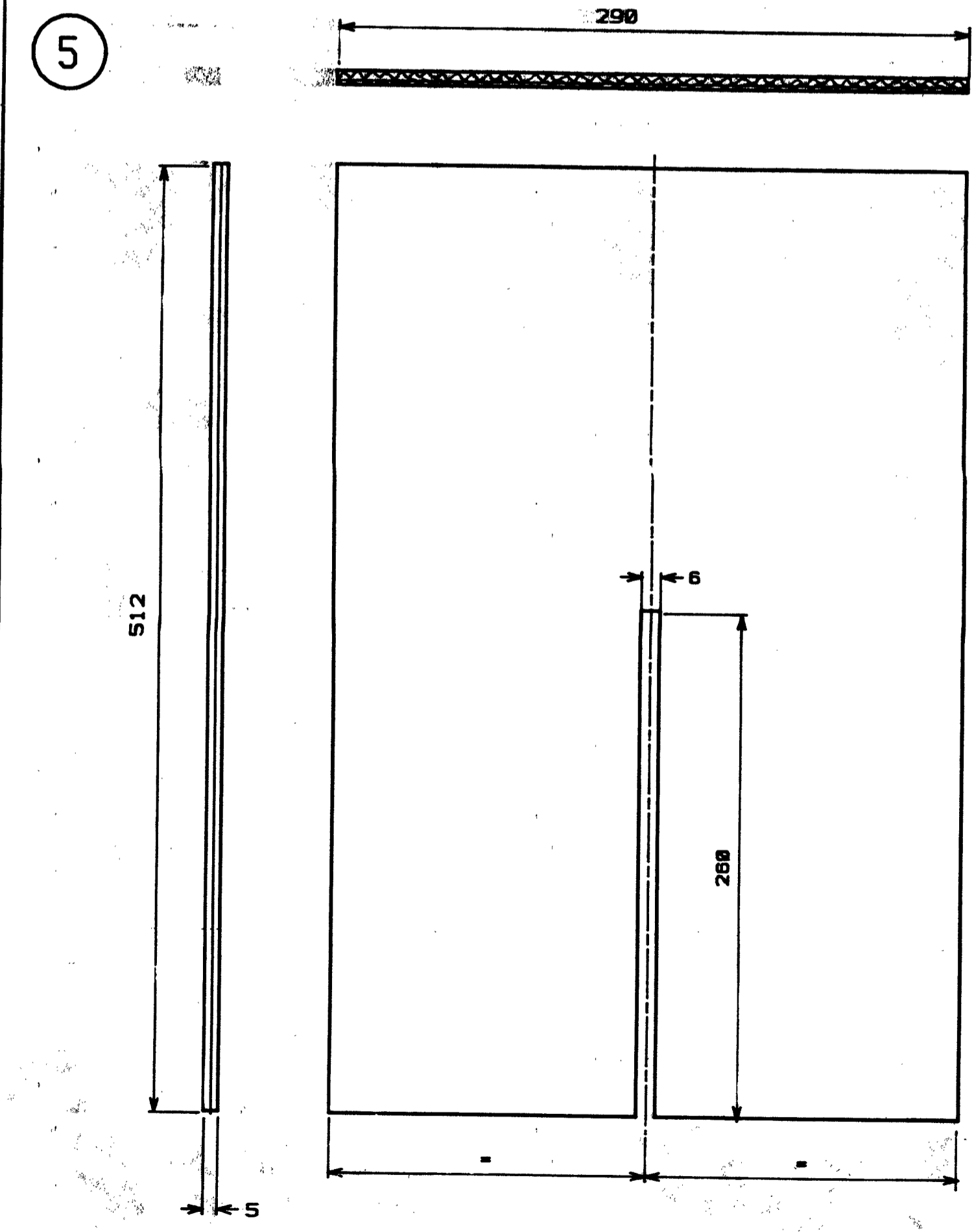

PARTITION NO. OFF- 2

NOTES:
 PART NO. 1: 150 GSM KRAFT PAPER, 5 PLY, DOUBLE WALL, VERTICAL NARROW FLUTTING, 5mm THICK.
 PART NO. 2: 120 GSM KRAFT PAPER, 13 PLY, SIX WALL, NARROW FLUTTING 15mm THICK & CROSS FLUTED, i.e. ALTERNATE FLUTES SHOULD RUN ACROSS EACH OTHER.
 PART NO. 3: 120 GSM KRAFT PAPER, 13 PLY, SIX WALL, NARROW FLUTTING 15mm THICK & CROSS FLUTED, i.e. ALTERNATE FLUTES SHOULD RUN ACROSS EACH OTHER.
 PART NO. 4: 120 GSM KRAFT PAPER, 13 PLY, SIX WALL, VERTICAL NARROW FLUTTING, 15mm THICK.
 EACH BOX IS TO HOLD COMPONENTS OF MASS 14.4 Kg.
 PARTS TO BE MARKED WITH THE MANUFACTURER'S NAME/INITIAL OR TRADE MARK.
 GENERAL WORKMANSHIP & FINISH SHALL BE GOOD THROUGHOUT.
 ALL PARAMETERS ARE GOVERNED BY THE SPECN. IS:2771 (PART-1) LATEST ISSUE & SUBJECTED TO PROPER FITMENT OF ALL THE PARTS.

PART	DESCRIPTION	NO. OFF	BRUISING STRENGTH	REMARK
7	STAPLES, MS GALVANISED 12X308.8 THICK. AS REQD			
6	BASE SUPPORT	1		
5	PARTITION	2		
4	SIDE SHOCK ABSORBER	4		
3	MOUTH SUPPORT	1		
2	SHOCK ABSORBER (TOP & BOTTOM)	2		
1	PACKING BOX	1	10 kg/cm ²	

REV	DATE	DESCRIPTION	SIGN
D	19/07/99	DESIGN UPDATED	
C	28-5-94	PRINTED IN ENGLISH ADDED	
B	16-1-04	SYMBOLS CHANGED ENGLISH TO HINDI	
A	24-11-94	STENCILING NOTE ADDED	

DIMENSIONS ARE IN mm		MATERIAL		ORDNANCE FACTORY	
SCALE	1:1	NOMENCLATURE	AMBAJHARI		
DATE	1994	DATE	DRAWING NO.		
			CC-363E		
			SHEET NO. 1		
			NO. OF SHEETS - 1		
			M/C		
			STORE		
			CC 76.2 NA		
			COMPT. CC-346		