

ITEM NO.	PART NUMBER	DESCRIPTION	QTY.
1	M-8001 FRAME, CARRYING HANDLE (10208112)	FRAME, CARRYING HANDLE, 00W50BMG	1
2	M-8002 POST, CARRYING HANDLE (10208114)	POST, CARRYING HANDLE, 00W50BMG	1
3	M-8003 CARRYING HANDLE (10208113)	CARRYING HANDLE, 00W50BMG	1
4	M-8010 LOCK ASSEMBLY, CARRYING HANDLE (10208115)	LOCK ASSEMBLY, CARRYING HANDLE, 00W50BMG	1
5	M-8004 PIN, SPRING, STRIGHT (10208118)	PIN, SPRING, STRAIGHT, 00W50BMG	1
6	91333A160	LOCKNUT, 5/16-18, NYLON INSERT, 00W50BMG	1
7	16, NARROW (91434A135)	WASHER, FLAT, 5/16, NARROW, 00W50BMG	1

REVISIONS				
ZONE	REV.	DESCRIPTION	DATE	APPROVED
	A	CREATE DRAWING	10/30/2008	J. HERSHBERGER
	B	ADDED MCMASTER CARR PART NUMBERS TO ITEM NUMBERS 6 AND 7	7/6/2012	BAM
	C	CHANGED PART NUMBER ON ITEM 6 FROM 91434A160 TO 91434A135	10/24/2012	BAM

M  
8000

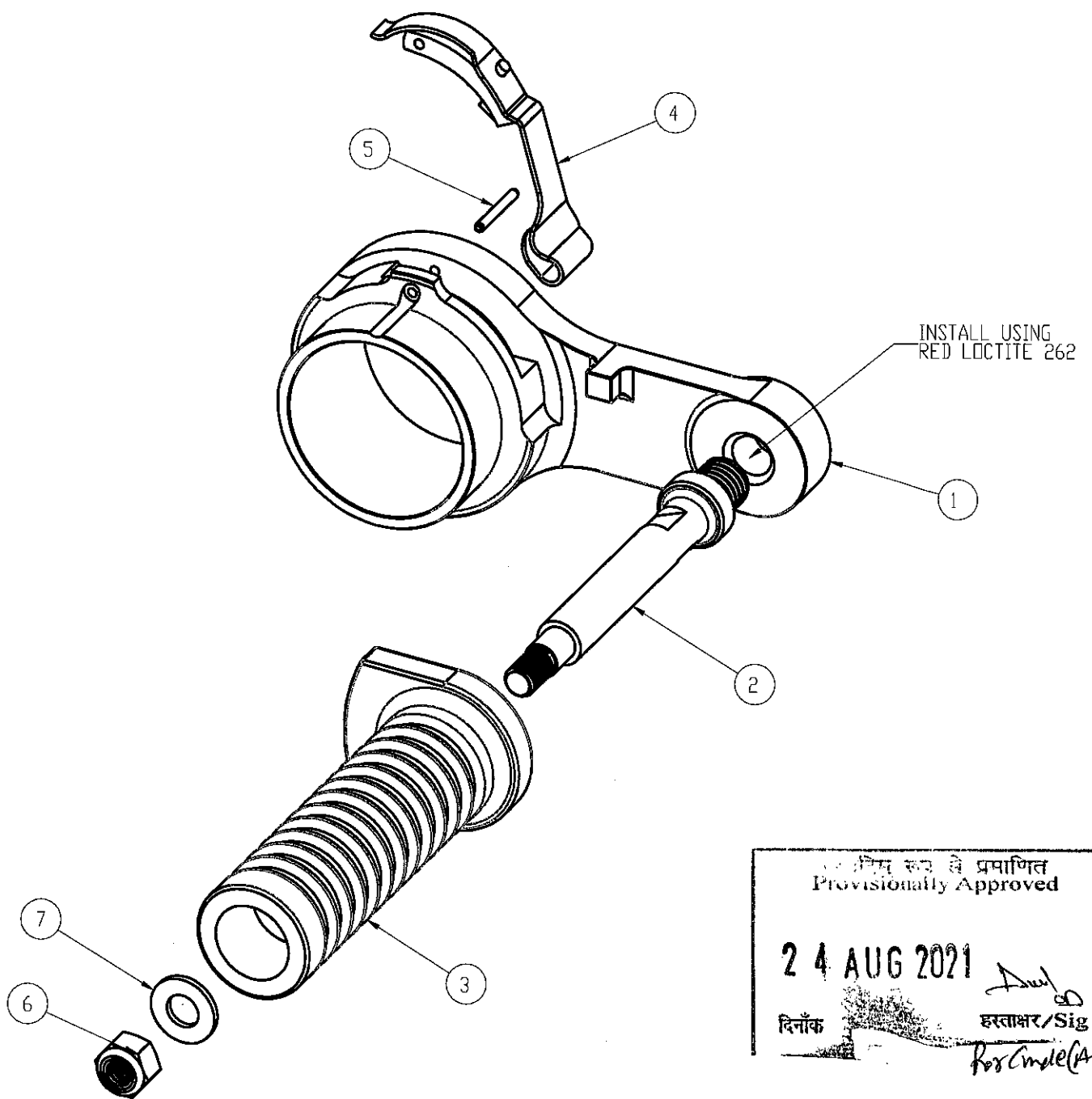
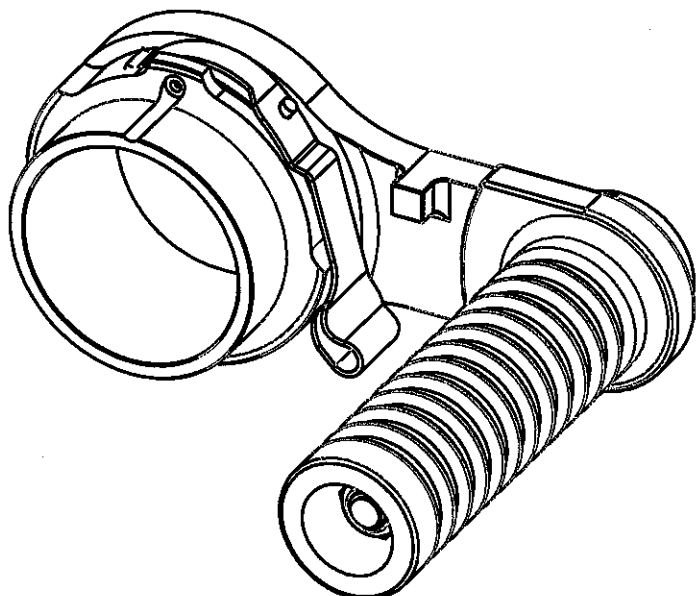

प्रमाणित रूप से प्रमाणित  
Provisionally Approved  
24 AUG 2021  
दिनांक  
हस्ताक्षर/Sig  
For Cmde(AP)

UNLESS OTHERWISE SPECIFIED		NAME	DATE	OHIO ORDNANCE WORKS, INC.
DIMENSIONS ARE IN MM(INCHES) ALL THREAD DIM. ARE IN INCHES		BRAWN	HERSH	
TOLERANCES:		CHECKED		ASSEMBLY, CARRYING HANDLE, 00W50BMG
FRACTIONAL: ±0.015		ENG APPR.		
ANGULAR: EACH 41° BEND TWO PLACE DECIMAL ±0.25 THREE PLACE DECIMAL ±0.127		REG APPR.		
INTERPRET GEOMETRIC TOLERANCING PER		QA		SIZE
MATERIAL		COMMENTS:		C
FINISH				10208111
DO NOT SCALE DRAWING				REV
				C
				SCALE: 1:1
				WEIGHT:
				SHEET 1 OF 1

PROPRIETARY AND CONFIDENTIAL  
THE INFORMATION CONTAINED IN THIS DRAWING IS THE SOLE PROPERTY OF OHIO ORDNANCE WORKS, INC. ANY REPRODUCTION IN PART OR AS A WHOLE WITHOUT THE WRITTEN PERMISSION OF OHIO ORDNANCE WORKS, INC. IS PROHIBITED.



M  
8005

REVISIONS

ZONE	REV.	DESCRIPTION	DATE	APPROVED
	A	CREATE DRAWING	8/24/2018	T. HARDMAN

NOTES:

1. McMASTER-CARR PART NUMBER 91434A135
2. MATERIAL: STEEL
3. FINAL PROTECTIVE FINISH: FINISH 5.3.1.2 OR 5.3.2.2 OF MIL-STD-171, ALT: McMASTER BLACK LUSTER ACCEPTABLE.
4. BREAK SHARP EDGES 0.127 TO 0.381

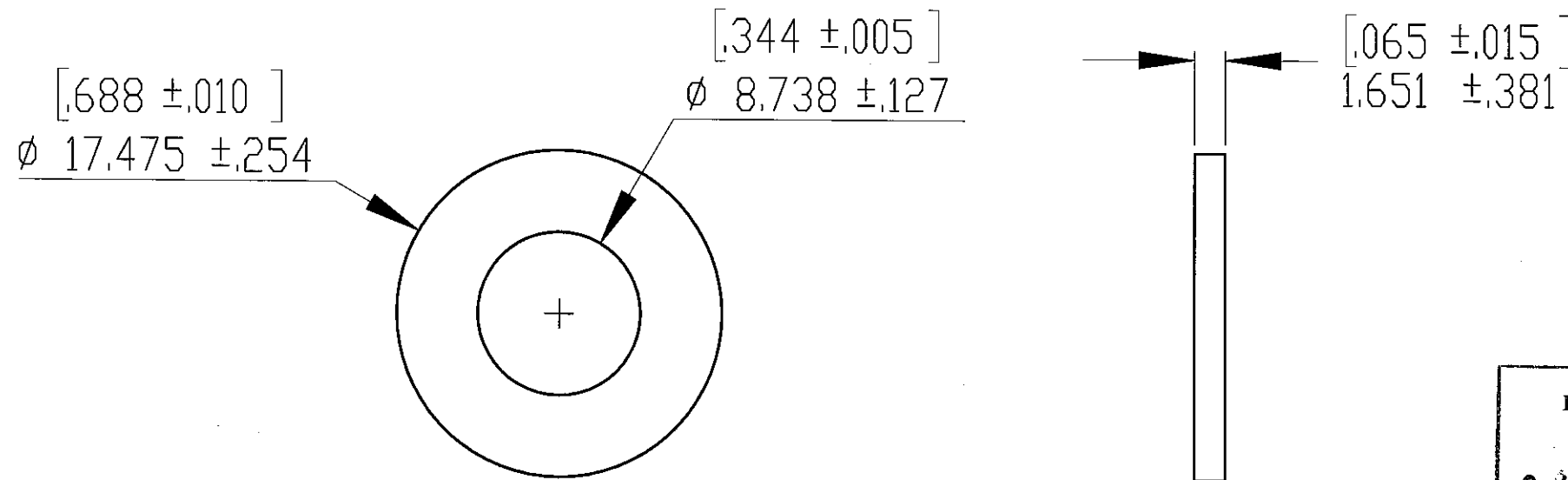

अप्रतिम रूप से प्रमाणित  
 Provisionally Approved

24 AUG 2021

दिनांक  
 हस्ताक्षर/Sig  
 for (Inde (APP))

<p><b>ITAR CONTROLLED</b></p> <p>THIS DOCUMENT IS CONTROLLED UNDER THE ITAR. IT MAY NOT BE PROVIDED TO A NON-U.S. RESIDENT WITHOUT THE WRITTEN APPROVAL OF THE U.S. GOV'T. VIOLATIONS WILL RESULT IN CIVIL OR CRIMINAL PENALTIES.</p>	<p>UNLESS OTHERWISE SPECIFIED:                  DIMENSIONS ARE IN MM/(INCHES)                  ALL THREAD DIM. ARE IN INCHES</p>	NAME	DATE	OHIO ORDNANCE WORKS, INC.	
	<p>TOLERANCES:                  FRACTIONAL                  ANGULAR: MACH ± BEND                  TWO PLACE DECIMAL ±0.254                  THREE PLACE DECIMAL ±0.076</p>	DRAWN	TMH	8/24/18	WASHER, FLAT, 5/16, NARROW, 00W50BMG
<p>PROPRIETARY AND CONFIDENTIAL</p> <p>THE INFORMATION CONTAINED IN THIS DRAWING IS THE SOLE PROPERTY OF OHIO ORDNANCE WORKS, INC. ANY REPRODUCTION IN PART OR AS A WHOLE WITHOUT THE WRITTEN PERMISSION OF OHIO ORDNANCE WORKS, INC. IS PROHIBITED.</p>	<p>INTERPRET GEOMETRIC TOLERANCING PER:</p>	CHECKED		SIZE A 91434A135 SCALE: 2:1 WEIGHT: SHEET 1 OF 1	REV A
	<p>MATERIAL                  STEEL</p>	<p>ENG APPR.</p>			
	<p>FINISH</p>	<p>MFG APPR.</p>			
	<p>DO NOT SCALE DRAWING</p>	<p>Q.A.</p>			
		<p>COMMENTS:</p>			





M  
8003

REVISIONS				
ZONE	REV.	DESCRIPTION	DATE	APPROVED
	A	CREATE DRAWING	10/24/2008	J. HERSHBERGER
E-4	B	DIMENSION WAS $\phi .715 \pm .01$ ADDED NOTE 3	4/2/2012	J. HERSHBERGER
	C	ADDED ALTERNATE MATERIAL	2/13/2017	G. HERSHBERGER
C-5, B-4, 5	D	ADDED $\pm .010$ TOLERANCE TO RIB SPACING AND RADIUS DIMENSIONS	9/17/2019	T. HARDMAN

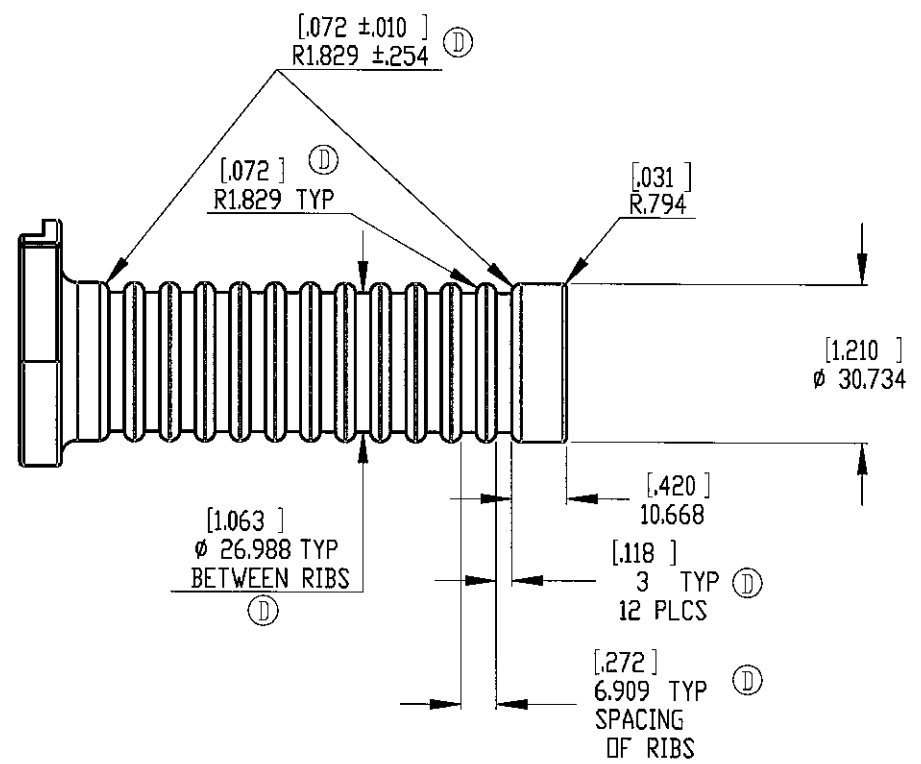
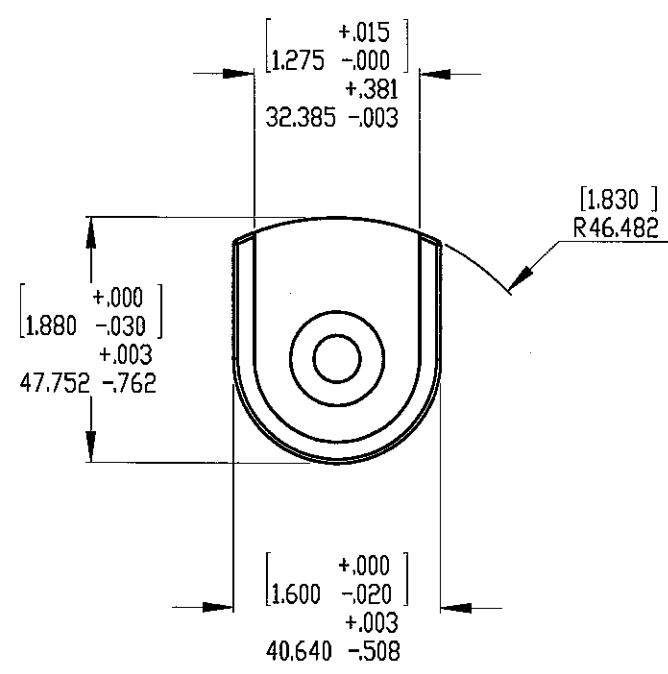
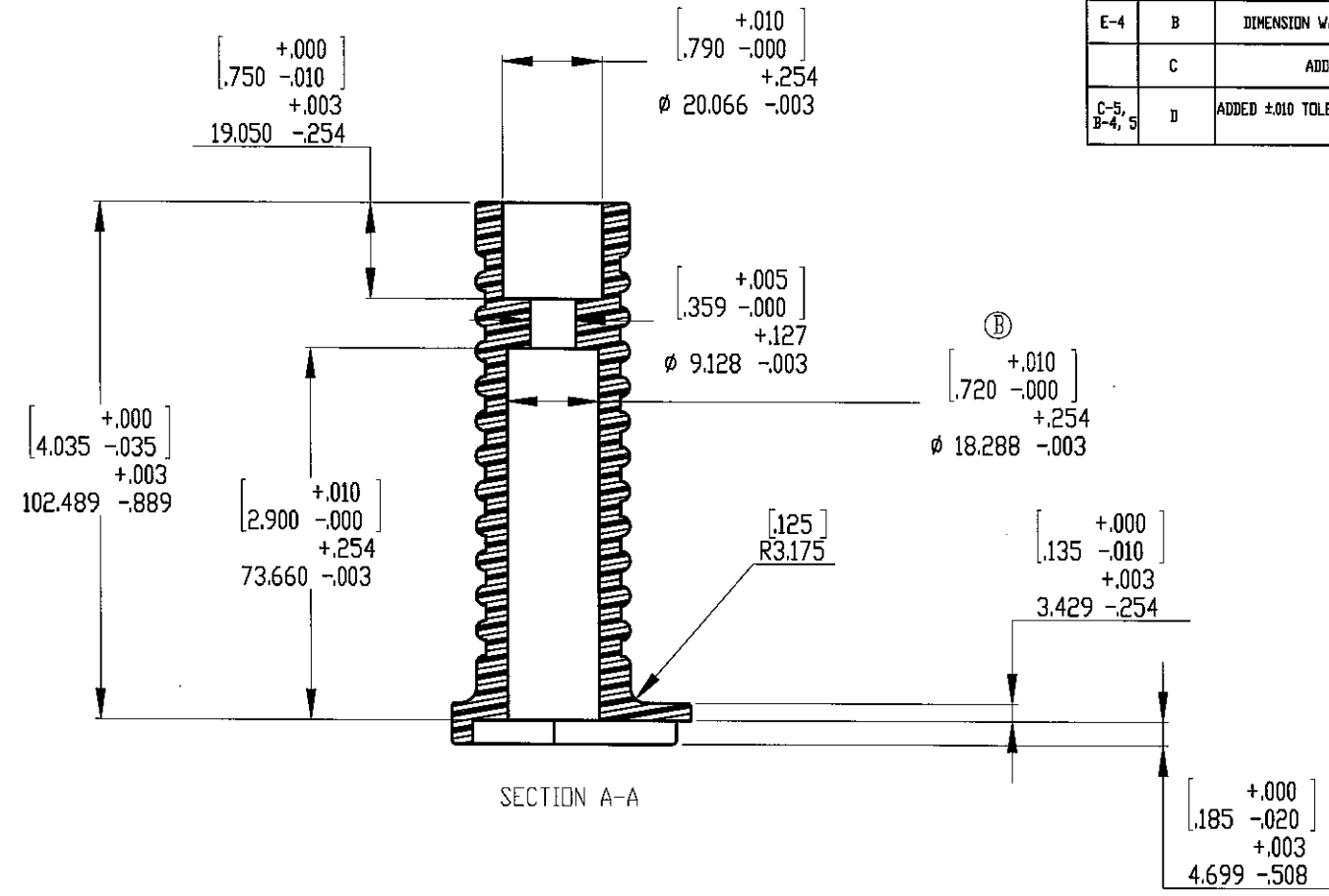
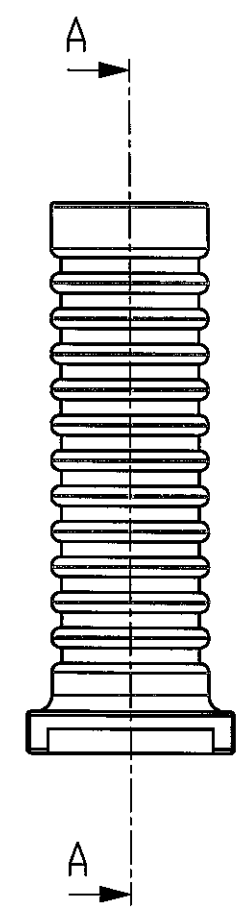

अंतरिम रूप से प्रमाणित  
Provisionally Approved

27 AUG 2021

हस्ताक्षर/Sig  
BooCmde(ADP)

NOTES:

- BREAK EDGES/REMOVE BURRS  $0.076 \pm 0.305$  UNLESS OTHERWISE SPECIFIED
- MATERIAL: PLASTIC, MOLDING, THERMOSETTING, SPEC MIL-M-14, SPEC ASTM D5948, TYPE CFI-20, OR EQUIVALENT. COLOR: BLACK
- ALTERNATE MATERIAL: PLASTIC, INJECTION MOLDING THERMALPLASTIC RESIN, DELRIN 500P BK602.
- APPLICABLE DRAFT ALLOWABLE IF PART IS MOLDED, UP TO 1 PER SIDE.

PROPRIETARY AND CONFIDENTIAL  
THE INFORMATION CONTAINED IN THIS DRAWING IS THE SOLE PROPERTY OF OHIO ORDNANCE WORKS, INC. ANY REPRODUCTION IN PART OR AS A WHOLE WITHOUT THE WRITTEN PERMISSION OF OHIO ORDNANCE WORKS, INC. IS PROHIBITED.

UNLESS OTHERWISE SPECIFIED:		NAME	DATE	OHIO ORDNANCE WORKS, INC.
DIMENSIONS ARE IN MM/INCHES ALL THREAD DIM ARE IN INCHES		DRAWN	HERSH	
TOLERANCES:		CHECKED		
FRACTIONAL .30/15		ENG APPR.		
ANGULAR MAX 45° BEND		MFG APPR.		
TWO PLACE DECIMAL $\pm 0.25$		D.A.		
THREE PLACE DECIMAL $\pm 0.127$		COMMENTS:		
INTERPRET GEOMETRIC TOLERANCING PER:				
MATERIAL: SEE NOTE 2				
FINISH:				
DO NOT SCALE DRAWING				

SIZE	10208113	REV	D
SCALE: 1:1	WEIGHT:	SHEET 1 OF 1	

REVISIONS				
ZONE	REV.	DESCRIPTION	DATE	APPROVED
	A	CREATE DRAWING	10/24/2008	J. HERSHBERGER
B,C-4	B	ADDED WRENCH FLATS	3/28/2012	J. HERSHBERGER
	C	ADDED LOCATION FOR WRENCH FLATS	4/6/2012	J. HERSHBERGER

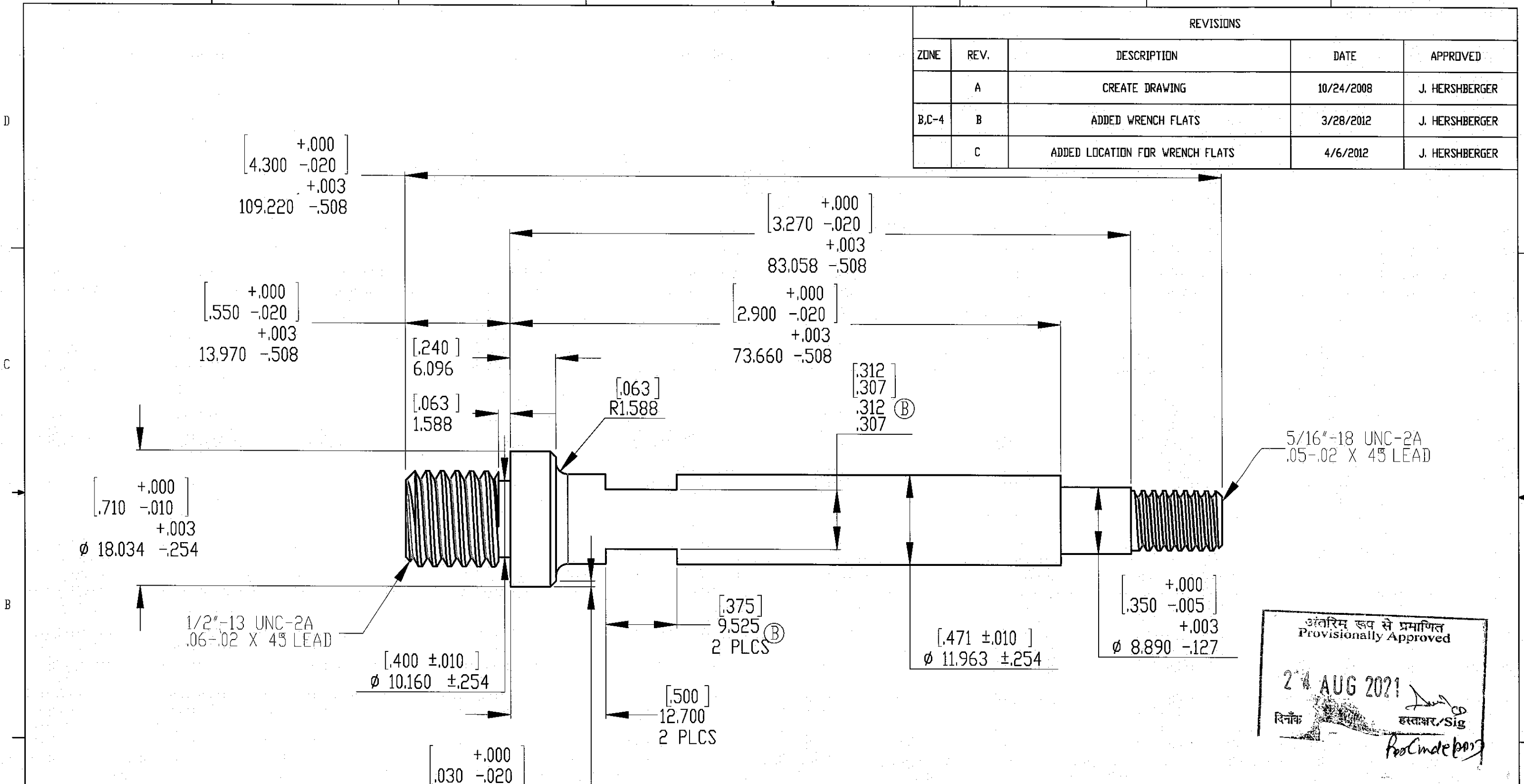

अंतरिम रूप से प्रमाणित  
Provisionally Approved

24 AUG 2021

दिनांक: \_\_\_\_\_ हस्ताक्षर/Sig \_\_\_\_\_  
ProCmde (signature)

- NOTES:
- BREAK EDGES 0.076+0.305 UNLESS OTHERWISE SPECIFIED
  - MATERIAL: STEEL, AISI 1040, 1050, 4140, 4340

<p><b>ITAR CONTROLLED</b></p> <p>THIS DOCUMENT IS CONTROLLED UNDER THE ITAR. IT MAY NOT BE PROVIDED TO A NON-U.S. RESIDENT WITHOUT THE WRITTEN APPROVAL OF THE U.S. GOV'T. VIOLATIONS WILL RESULT IN CIVIL OR CRIMINAL PENALTIES.</p> <p>PROPRIETARY AND CONFIDENTIAL</p> <p>THE INFORMATION CONTAINED IN THIS DRAWING IS THE SOLE PROPERTY OF OHIO ORDNANCE WORKS, INC. ANY REPRODUCTION IN PART OR AS A WHOLE WITHOUT THE WRITTEN PERMISSION OF OHIO ORDNANCE WORKS, INC. IS PROHIBITED.</p>	UNLESS OTHERWISE SPECIFIED	NAME	DATE	<p>OHIO ORDNANCE WORKS, INC.</p> <p><b>POST, CARRYING HANDLE, DDW50BMG</b></p> <p>SIZE B 10208114 REV C</p> <p>SCALE: 2:1 WEIGHT: SHEET 1 OF 1</p>	
	DIMENSIONS ARE IN MM/(INCHES) ALL THREAD DIM. ARE IN INCHES	DRAWN	HERSH		10/24/08
	TOLERANCES:	CHECKED			
	FRACTIONAL ±0.015 ANGULAR: MACH #1° BEND TWO PLACE DECIMAL ±0.25 THREE PLACE DECIMAL ±0.127	ENG APPR.			
INTERPRET GEOMETRIC TOLERANCING PER:	MFG APPR.				
MATERIAL SEE NOTE 2	G.A.				
FINISH PARKERIZE, GRAY	COMMENTS:				
DD NOT SCALE DRAWING					

M  
8010

ITEM NO.	PART NUMBER	DESCRIPTION	QTY.
1	M-8011 LOCK, CARRYING HANDLE (10208116)	LOCK, CARRYING HANDLE, 00W50BMG	1
2	M-8012 SPRING, LOCK, CARRYING HANDLE (10208117)	SPRING, LOCK, CARRYING HANDLE, 00W50BMG	1
3	M-8013 RIVET, LOCK ASSEMBLY, CARRYING HANDLE (10208119)	RIVET, LOCK ASSEMBLY, CARRYING HANDLE, 00W50BMG	1

REVISIONS				
ZONE	REV.	DESCRIPTION	DATE	APPROVED
	A	CREATE DRAWING	10/30/2008	J. HERSHBERGER

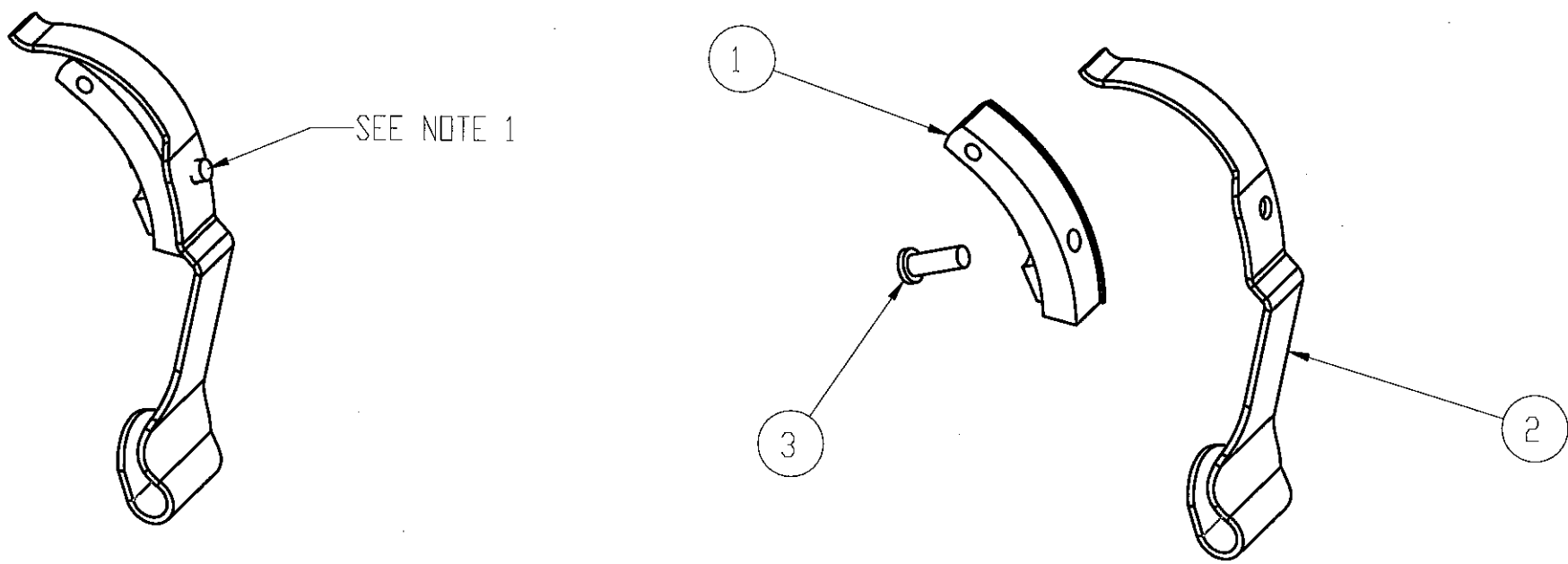

अंतरिम रूप से प्रमाणित  
Provisionally Approved  
24 AUG 2021  
दिनांक  
हस्ताक्षर/Sig  
Pro (male/10/1)

NOTES:

- ENSURE LOCK SPRING IS CLAMPED AGAINST LOCK BODY BEFORE RIVETING THE ASSEMBLY TOGETHER. FORM RIVET TO HAVE A ROUND HEAD.

PROPRIETARY AND CONFIDENTIAL  
THE INFORMATION CONTAINED IN THIS DRAWING IS THE SOLE PROPERTY OF DHIO ORDNANCE WORKS, INC. ANY REPRODUCTION IN PART OR AS A WHOLE WITHOUT THE WRITTEN PERMISSION OF DHIO ORDNANCE WORKS, INC. IS PROHIBITED.

UNLESS OTHERWISE SPECIFIED DIMENSIONS ARE IN MM/[INCHES] ALL THREAD DIM. ARE IN INCHES TOLERANCES: FRACTIONAL ±0.015 ANGULAR: MACH ±1° BEND TWO PLACE DECIMAL ±0.25 THREE PLACE DECIMAL ±0.127		NAME	DATE	DHIO ORDNANCE WORKS, INC.  LOCK ASSEMBLY, CARRYING HANDLE, 00W50BMG
INTERPRET GEOMETRIC TOLERANCING PER:	DRAWN	HERSH	10/30/08	
MATERIAL	CHECKED			
FINISH	ENG APPR.			
DO NOT SCALE DRAWING	MFG APPR.			
	Q.A.			SIZE B
	COMMENTS:			10208115
				REV A
				SCALE: 1:1
				WEIGHT:
				SHEET 1 OF 1



M  
8011

REVISIONS				
ZONE	REV.	DESCRIPTION	DATE	APPROVED
	A	CREATE DRAWING	10/27/2008	J. HERSHBERGER
	B	ADDED GD & T TO CURRENT STANDARDS	3/8/2017	G. HERSHBERGER

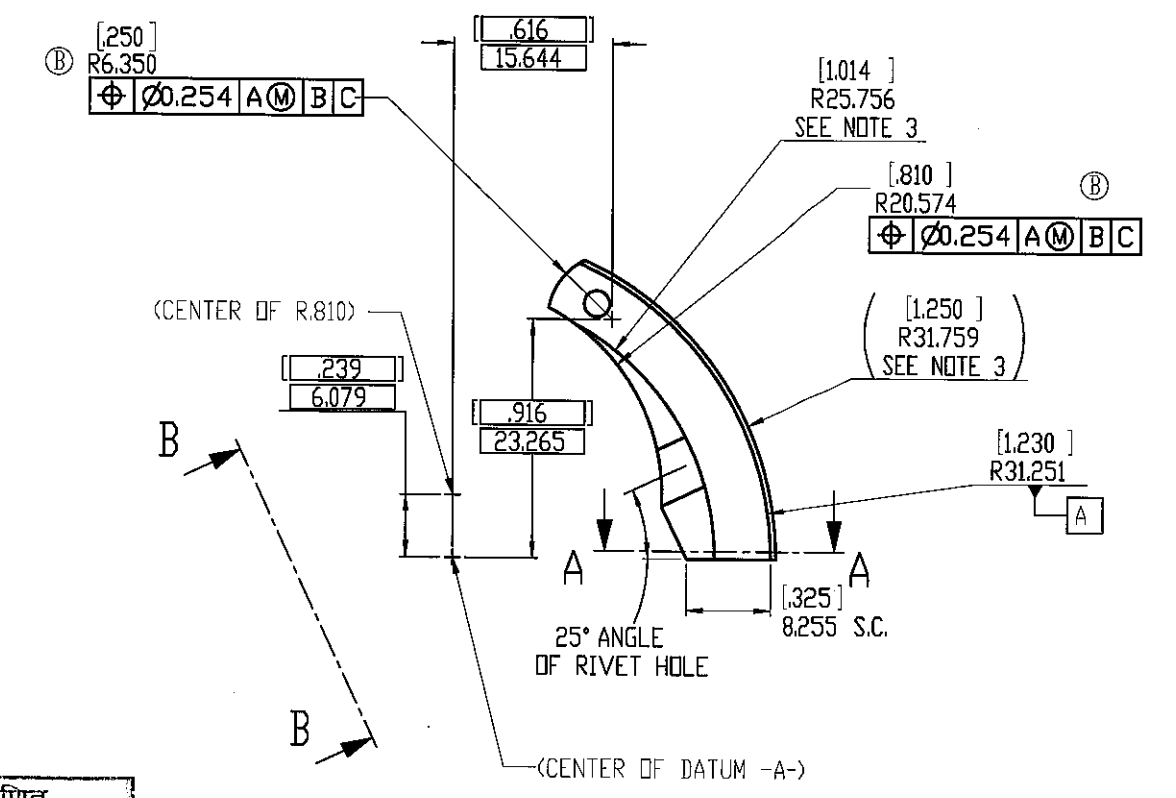
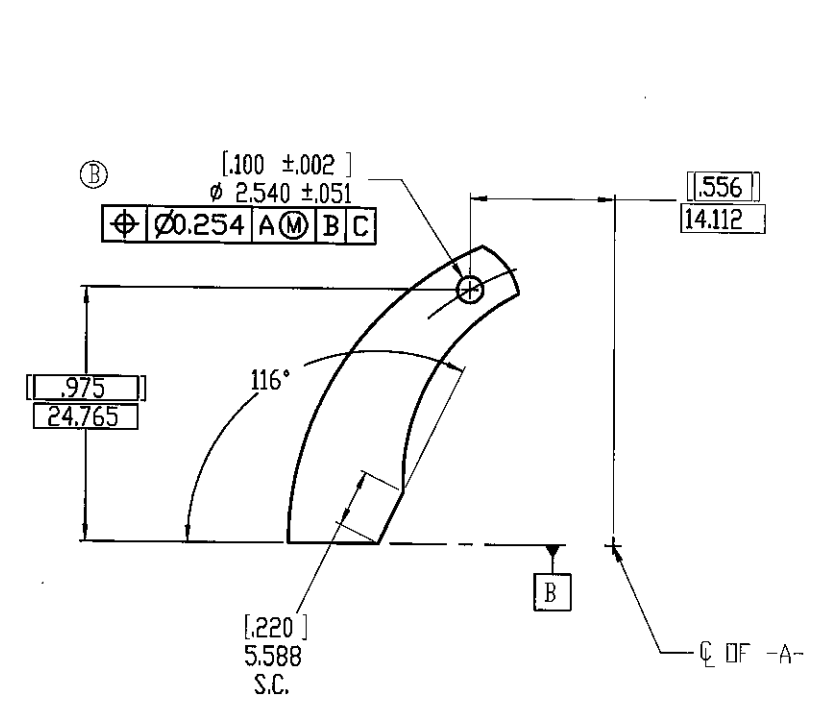
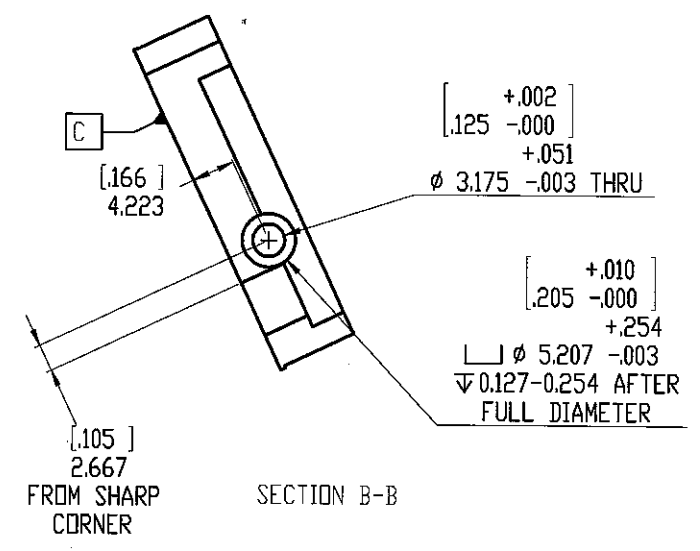
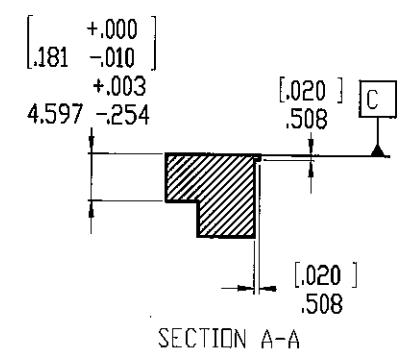

अंतरिम रूप से प्रमाणित  
Provisionally Approved

24 AUG 2021

दिनांक हस्ताक्षर/Sig  
Poo (male/AT/1)

- NOTES:
- BREAK EDGES 0.076+0.305 UNLESS OTHERWISE SPECIFIED.
  - MATERIAL: STEEL, AISI 1040, 1045, 1050, 4140, 4340.
  - THESE RADII SHARE THE SAME CENTERPOINT AS DATUM -A-
  - ASME Y14.5M-1994 APPLIES

PROPRIETARY AND CONFIDENTIAL  
THE INFORMATION CONTAINED IN THIS DRAWING IS THE SOLE PROPERTY OF OHIO ORDNANCE WORKS, INC. ANY REPRODUCTION IN PART OR AS A WHOLE WITHOUT THE WRITTEN PERMISSION OF OHIO ORDNANCE WORKS, INC. IS PROHIBITED.

UNLESS OTHERWISE SPECIFIED	NAME	DATE
DIMENSIONS ARE IN INCHES	DRAWN	HERSH
ALL THREAD DIA ARE IN INCHES	CHECKED	
TOLERANCES:	ENG APPR.	
FRACTIONAL ±0.015	NFG APPR.	
ANGULAR MATCH 41° BEND	D.A.	
TWO PLACE DECIMAL ±0.25	COMMENTS:	
THREE PLACE DECIMAL ±0.127		
INTERPRET GEOMETRIC TOLERANCING PER:		
MATERIAL: SEE NOTE 2		
FINISH: PARKERIZE, GRAY		
DO NOT SCALE DRAWING		

OHIO ORDNANCE WORKS, INC.	
LOCK, CARRYING HANDLE, 00W50BMG	
SIZE C	REV B
SCALE: 2:1	WEIGHT:
SHEET 1 OF 1	

M  
8012

REVISIONS				
ZONE	REV.	DESCRIPTION	DATE	APPROVED
	A	CREATE DRAWING	10/29/2008	J. HERSHBERGER
	B	ADDED SHEETS 2-4 (COMPARATOR CHARTS)	7/5/2012	J. HERSHBERGER

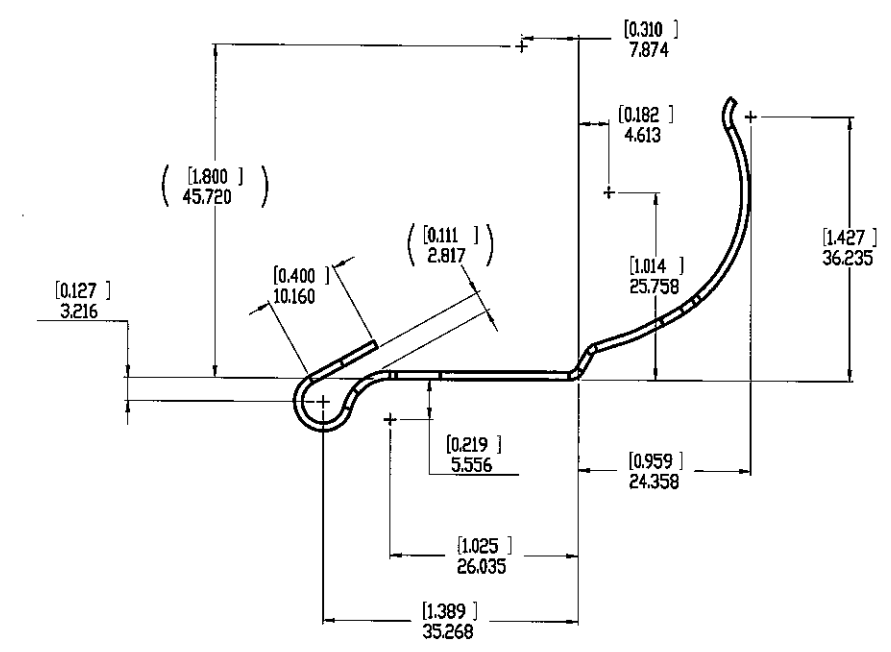
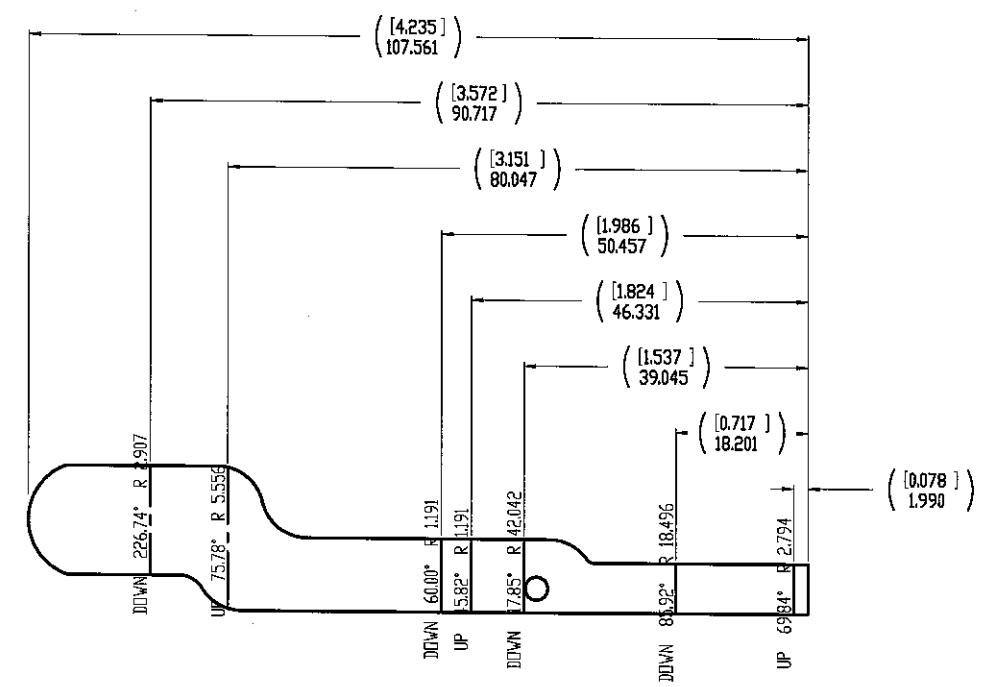

BEND CONFIGURATION

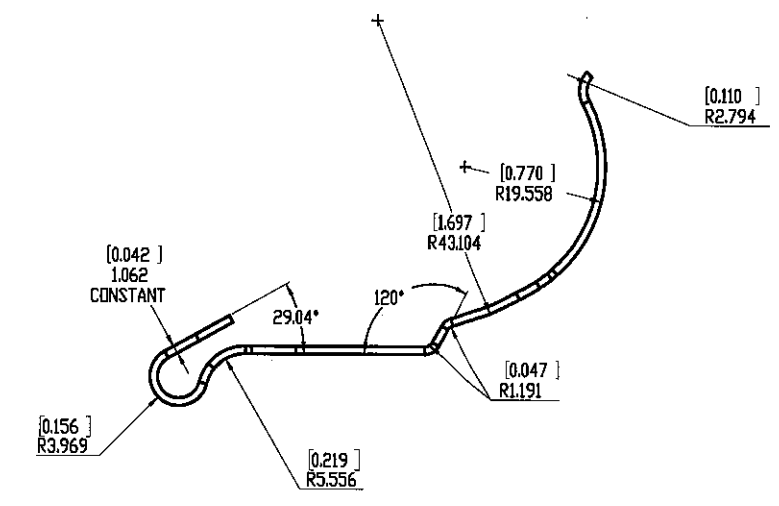
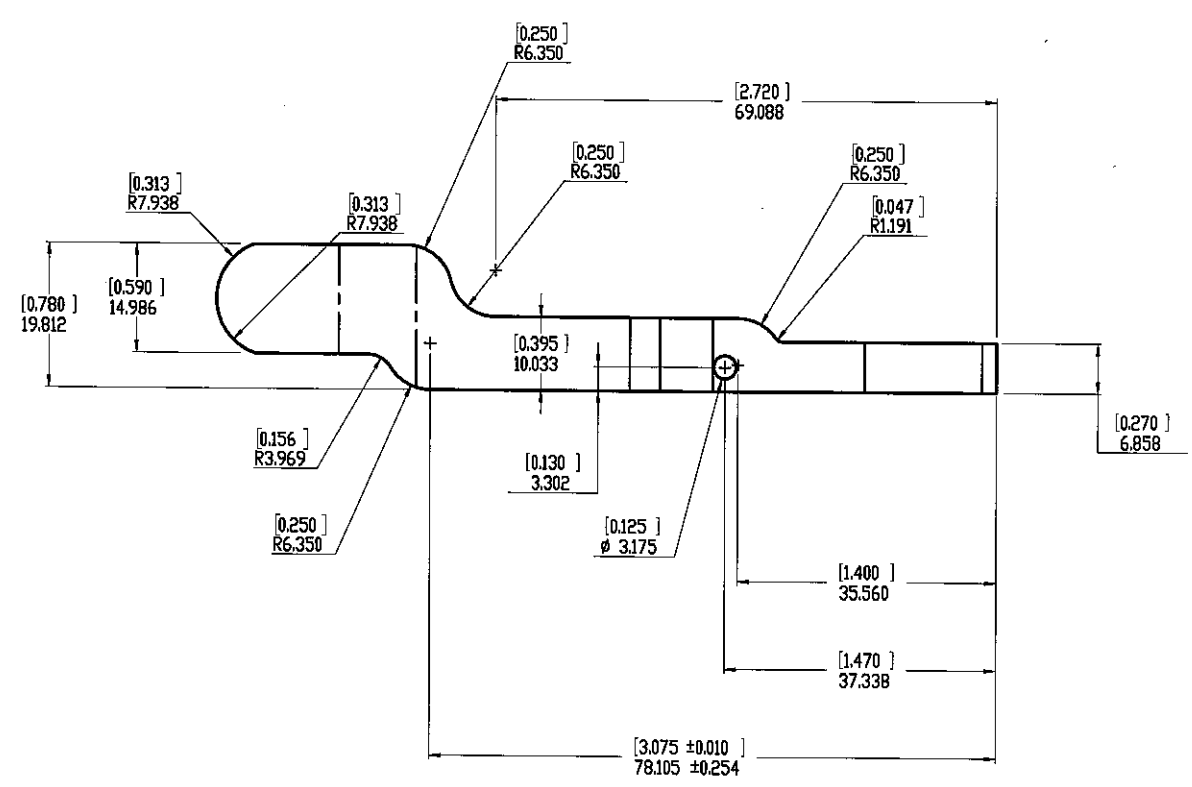
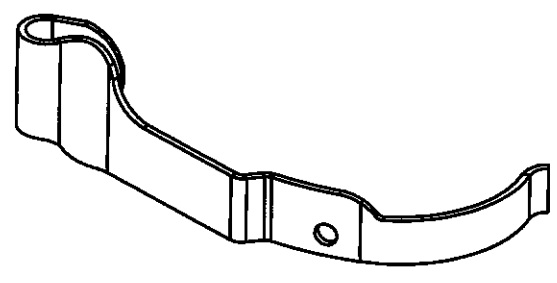

NOTES:  
 1. BREAK EDGES 0.127±0.178 UNLESS OTHERWISE SPECIFIED.  
 MATERIAL: STEEL, A151 1095, 6150.  
 HEAT TREATMENT: FOR 1095 STEEL: HEAT AT 787°-816°C, OIL QUENCH, TEMPER 1 HOUR MINIMUM TO HRC 45-50. FOR 6150 STEEL: HEAT AT 843° TO 871°C, OIL QUENCH, TEMPER 1 HOUR MINIMUM TO HRC 45-50.

प्राथमिक रूप से प्रमाणित  
 Provisionally Approved  
 24 AUG 2021  
 दिनांक  
 हस्ताक्षर/Sig  
 foo (mela@pp)

UNLESS OTHERWISE SPECIFIED		DATE	OHIO ORDINANCE WORKS, INC.	
FINISHES ARE TO PROCEED	DATE	10/29/08	NAME	J. HERSHBERGER
ALL THICK ENDS ARE TO BE	CHECKED		DATE	
FRONT SIDE	ENG APPR.		DATE	
ANGULAR SIDE	ENG APPR.		DATE	
THREE PLACE DECIMAL READ	ENG APPR.		DATE	
INTERPRET GEOMETRIC TOLERANCES PER	COMMENTS			
AS PER	SEE NOTE 2			
FINISH				

SIZE D 10208117 REV B  
 SCALE: 2:1 WEIGHT: SHEET 1 OF 4

D 10208117

M 8012

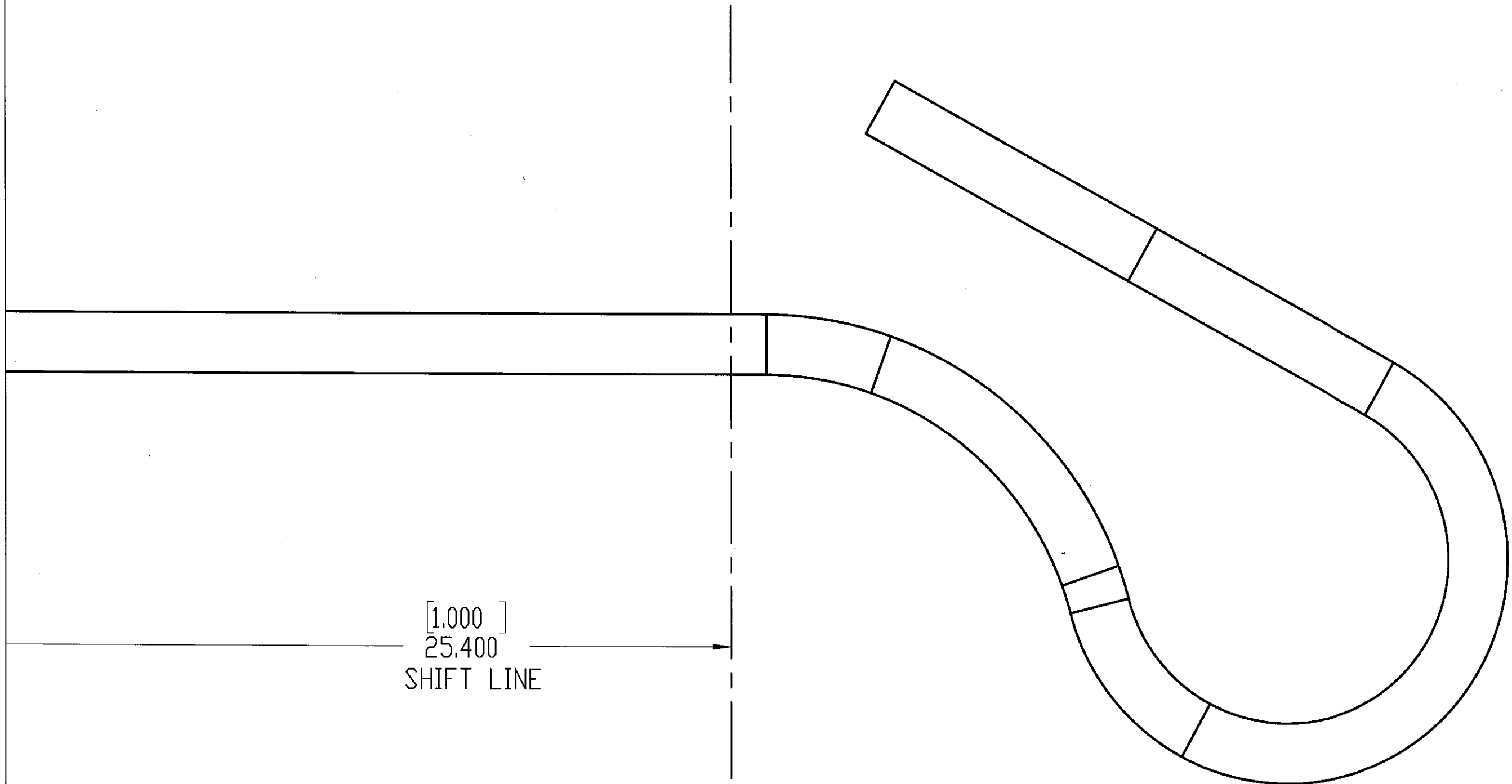

[1.000]  
25.400  
SHIFT LINE

OHIO ORDNANCE WORKS, INC.

SIZE	10208117	REV
A		B
SCALE: 10:1	WEIGHT:	SHEET 2 OF 4

प्रमाणित  
Provisionally Approved

24 AUG 2021

दिनांक  
हस्ताक्षर/Sig  
Poo (mele) (M)

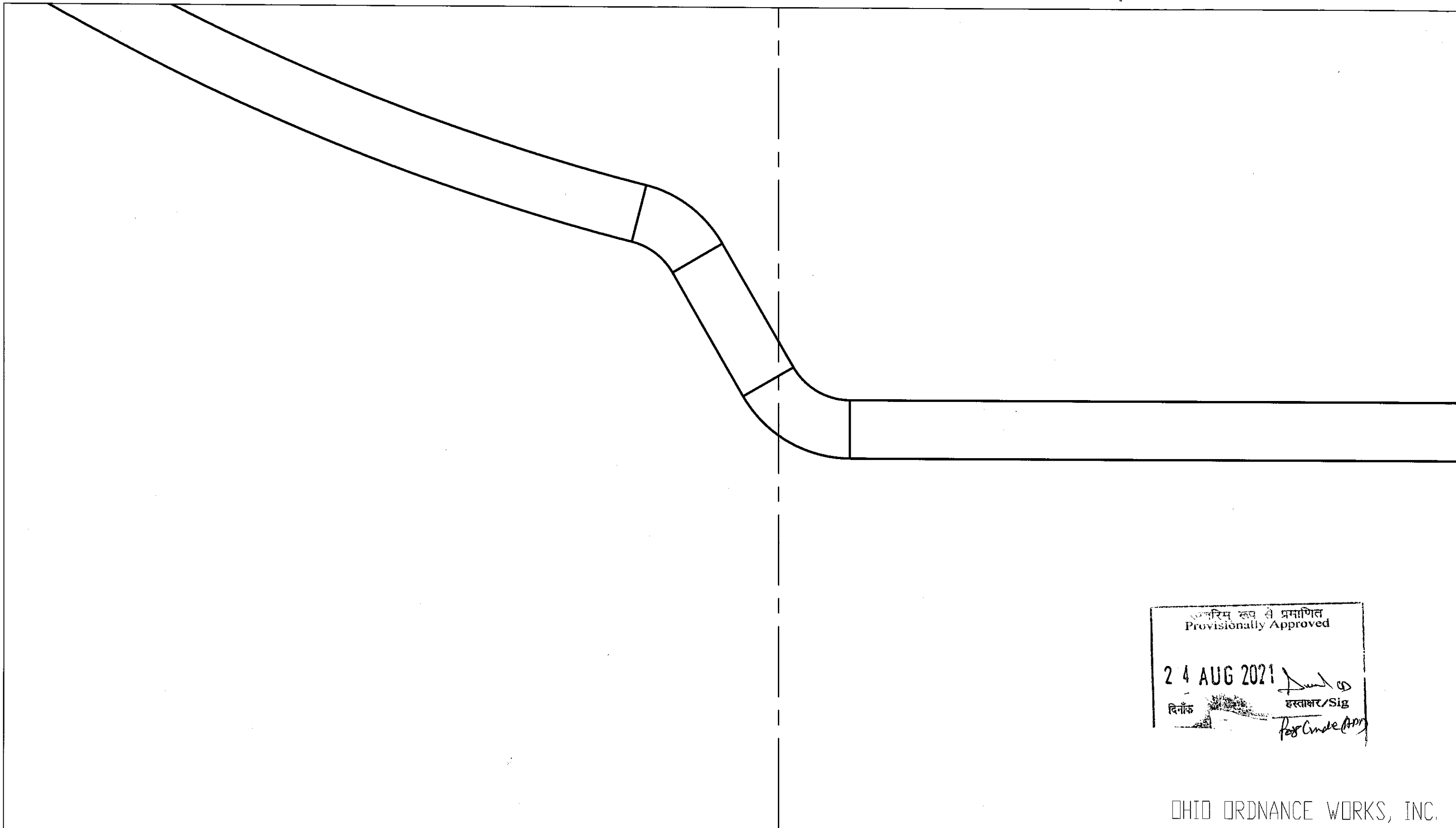

अप्रतिम रूप से प्रमाणित  
Provisionally Approved

24 AUG 2021

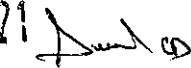
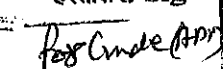
दिनांक  हस्ताक्षर/Sig  

OHIO ORDNANCE WORKS, INC.

SIZE		REV
A	10208117	B
SCALE: 10:1	WEIGHT:	SHEET 3 OF

M  
8012

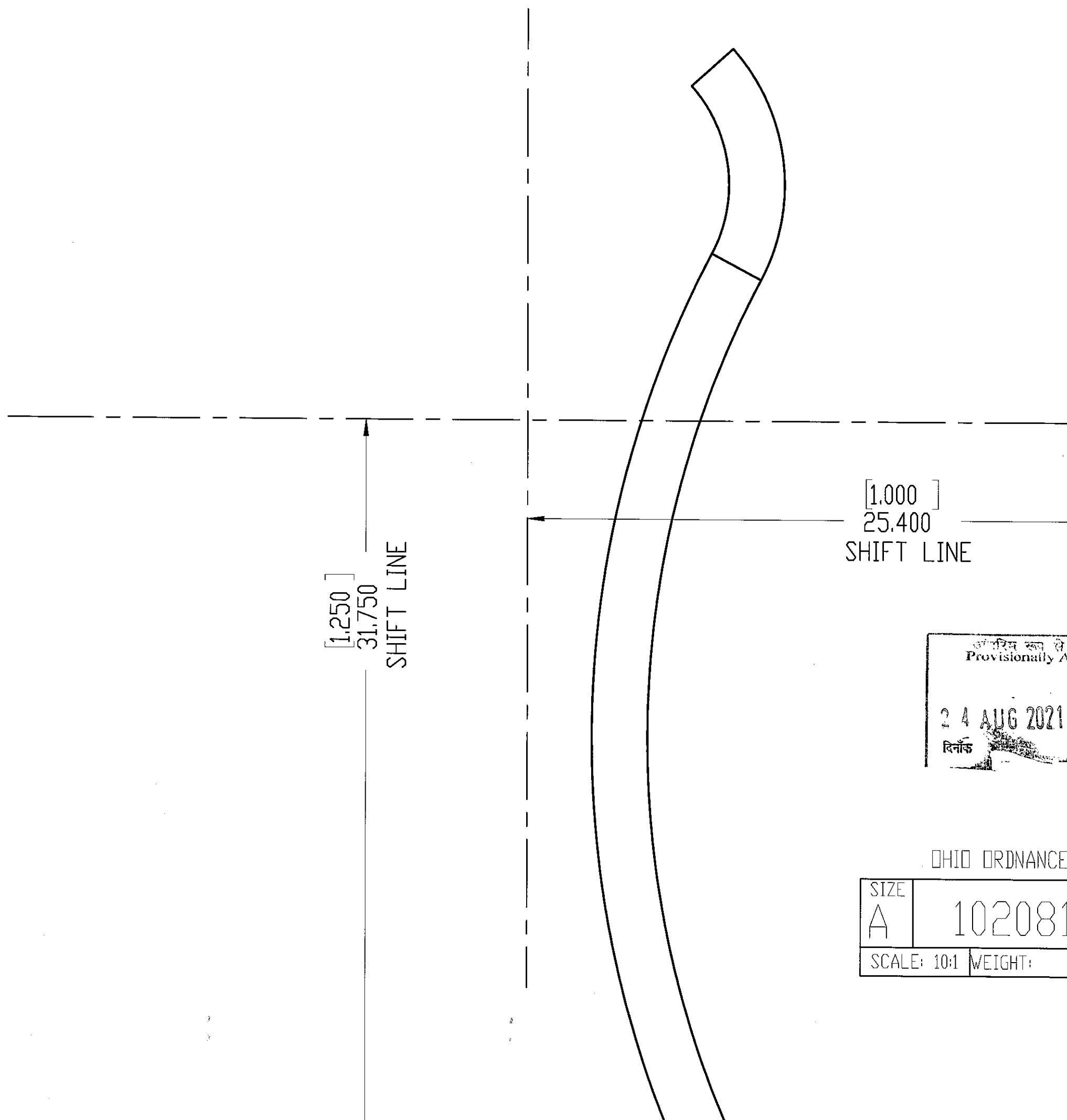

[1.250]  
31.750  
SHIFT LINE

[1.000]  
25.400  
SHIFT LINE

अप्रतिष्ठापित रूप से प्रमाणित  
Provisionally Approved  
24 AUG 2021  
दिनांक  
हस्ताक्षर/Sig  
Roc/mde(AP1)

OHIO ORDNANCE WORKS, INC.

SIZE		REV
A	10208117	B
SCALE: 10:1	WEIGHT:	SHEET 4 OF 4

NOTES:

1. MCMASTER NUMBER - 97855A140.
2. ALT: MS16562-122.

REVISIONS				
ZONE	REV.	DESCRIPTION	DATE	APPROVED
	A	CREATE DRAWING	10/30/2008	J. HERSHBERGER
	B	ADDED NOTE 1	10/24/2012	BAM

M  
8004

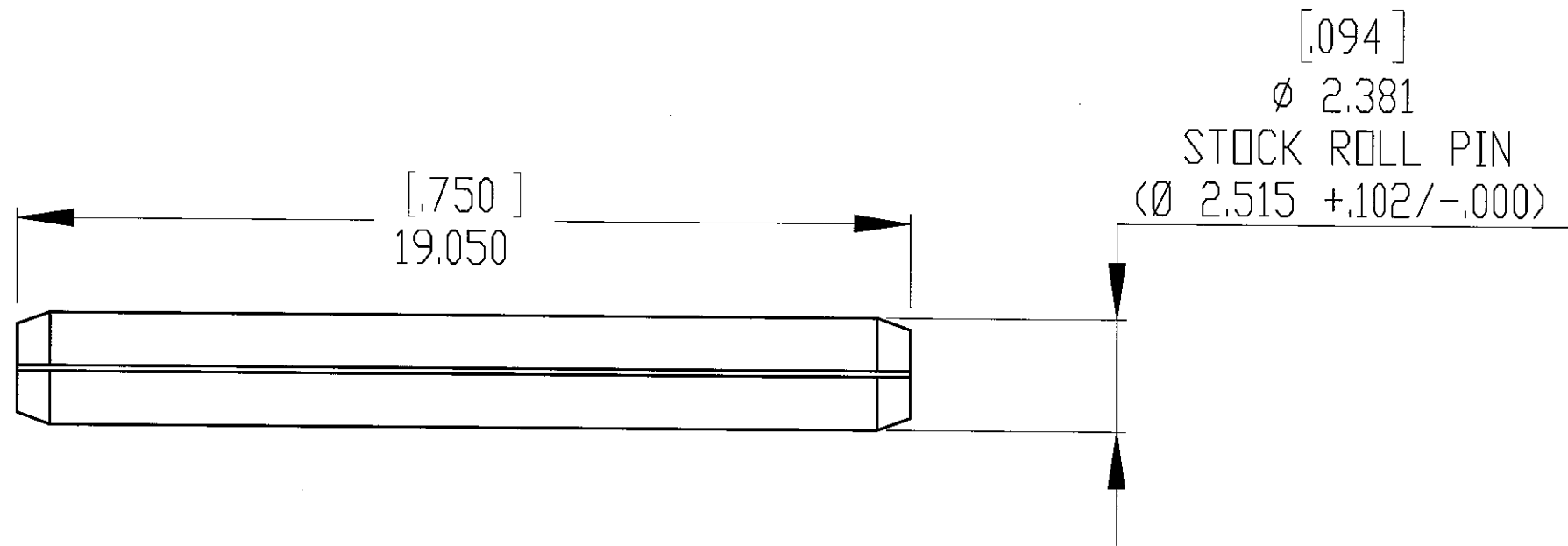

अंतरिम रूप से प्रमाणित  
Provisionally Approved  
24 AUG 2021  
हस्ताक्षर/Sig  
दिनांक

PROPRIETARY AND CONFIDENTIAL  
THE INFORMATION CONTAINED IN THIS DRAWING IS THE SOLE PROPERTY OF OHIO ORDNANCE WORKS, INC. ANY REPRODUCTION IN PART OR AS A WHOLE WITHOUT THE WRITTEN PERMISSION OF OHIO ORDNANCE WORKS, INC. IS PROHIBITED.

UNLESS OTHERWISE SPECIFIED: DIMENSIONS ARE IN MM/[INCHES] ALL THREAD DIM. ARE IN INCHES TOLERANCES: FRACTIONAL ANGULAR: MACH ± BEND TWO PLACE DECIMAL ±0.381 THREE PLACE DECIMAL ±0.127		NAME	DATE	OHIO ORDNANCE WORKS, INC.	
INTERPRET GEOMETRIC TOLERANCING PER:		DRAWN	HERSH	10/30/08	
MATERIAL 1050-1095 SPRING STEEL		CHECKED			
FINISH BLACK PHOSPHATE		ENG APPR.			
DO NOT SCALE DRAWING		MFG APPR.			
		Q.A.			
		COMMENTS:			
SIZE	10208118	REV	B		
A					
SCALE: 5:1	WEIGHT:	SHEET 1 OF 1			

