

GENERAL TOL : FINE / MEDIUM / COARSE
 CLASS TO IS: 2102
 DRG. CONVENTIONS CONFIRM TO INDIAN STANDARDS
 DIMENSIONS ARE IN mm UNLESS OTHERWISE STATED.

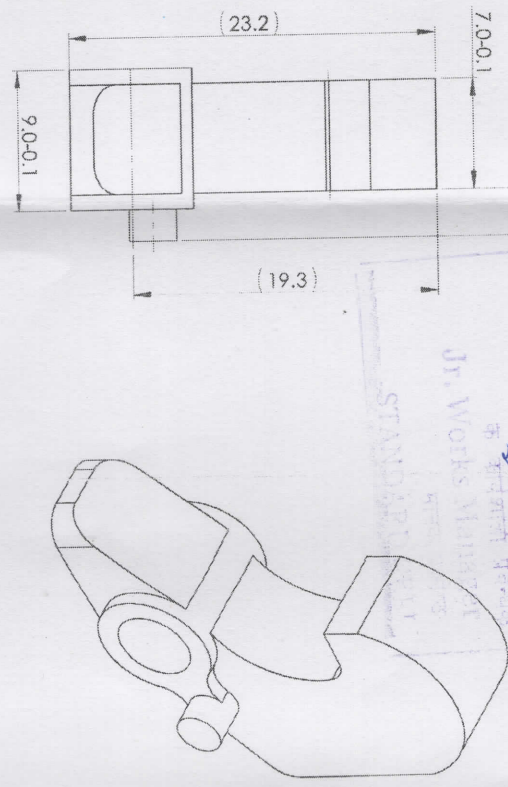
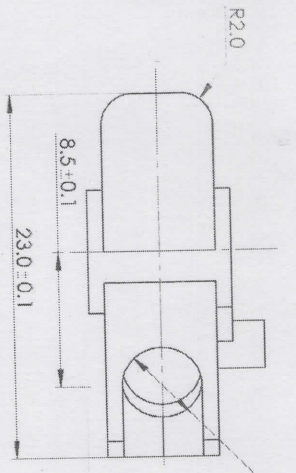
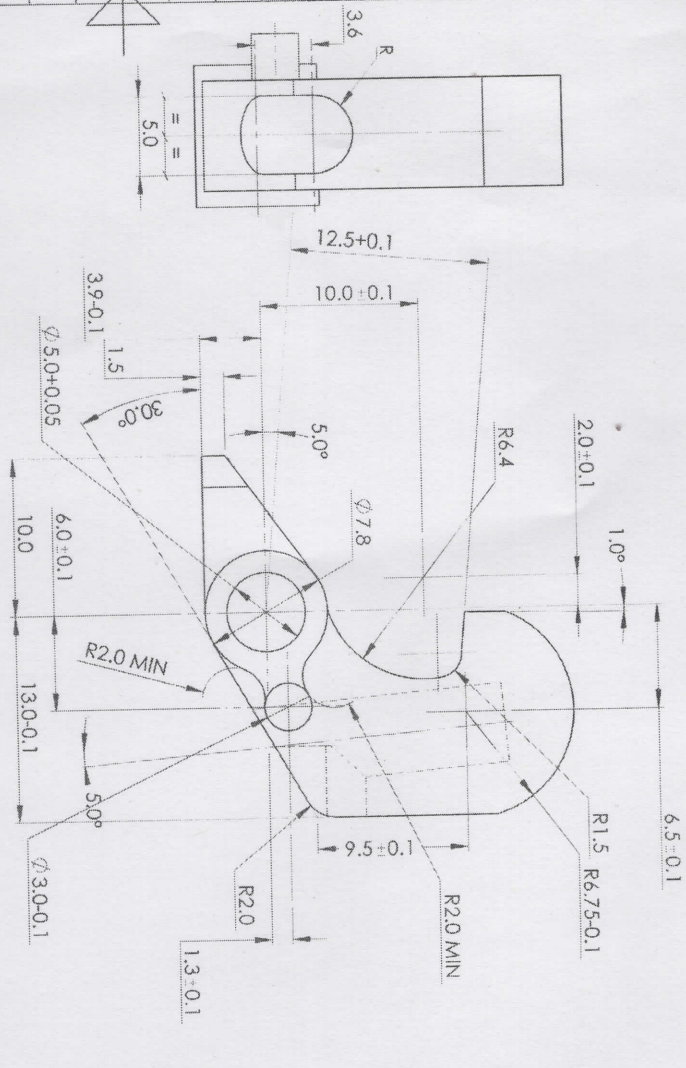

Handwritten signature
 Certified as correct copy
 of the original
 09/09/2019
 Dr. Works Manager
 STANDARDS

NOTES:-

- 1) REMOVE ALL SHARP EDGES AND BURRS.
- 2) TOLERANCE FOR ANGLES = 30° UNLESS OTHER STATED
- 3) HEAT TREATMENT : CASE HARDENED TO A DEPTH OF 0.10 TO 0.30
- 4) HARDENED : 500 TO 600 H.V.
- 5) IF COMPONENT TO BE MANUFACTURED THROUGH MIM ROUTE REFER ARDE SPECN. No. DRDO/ARDE/MIM/TSP/051/2019.
- 6) ALT. PROTECTIVE COATING : PHOSPHATED TO SPECN. IS:3618-1966, CLASS 'B'

Sr. No.	DATE	AUTHORITY	BRIEF RECORD	ZONE	CD	GO
DRN: SOURABH	DATE: 07/03/2019	CHECKED	MATERIAL: STEEL TO IS: 4432, 1988, Gr. 13N113C73			
SIGN: <i>Sourabh</i>	DATE: 07/03/2019	FOR DIRECTOR	PROTECTIVE FINISH: ELECTROLESS NICKEL-BORON NITRIDE (NIBN) COATING AS PER ARDE SPECN. NO. ARDE/SA/2016/COATING-02			
APPD.	DATE: 07/03/2019		TITLE: SEAR			
SCALE: 3:1	SHEET SIZE: A3	EST. MASS 10.69gm				
DESIGN AUTHORITY ARDE PUNE 411021						
DRG No. 0204	IC 03	SS 04	S 02	AA 14	A 010	00DA
JYFC	PART No.	DS CAT No.	AHSP			

1	2	3	4	5	6	7	8
---	---	---	---	---	---	---	---