

CERTIFIED CORRECT COPY
OF APPROVED DRAWINGS
AT THIS DATE.....

17.11.2020

Design & Drawing Office
Ordnance Factory,
Truochirappalli-620016

UN CONTROLLED COPY

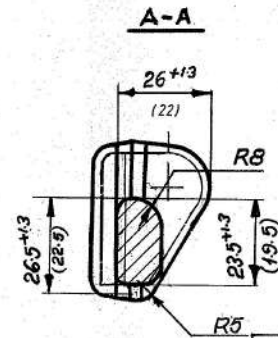
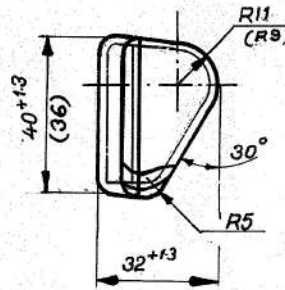
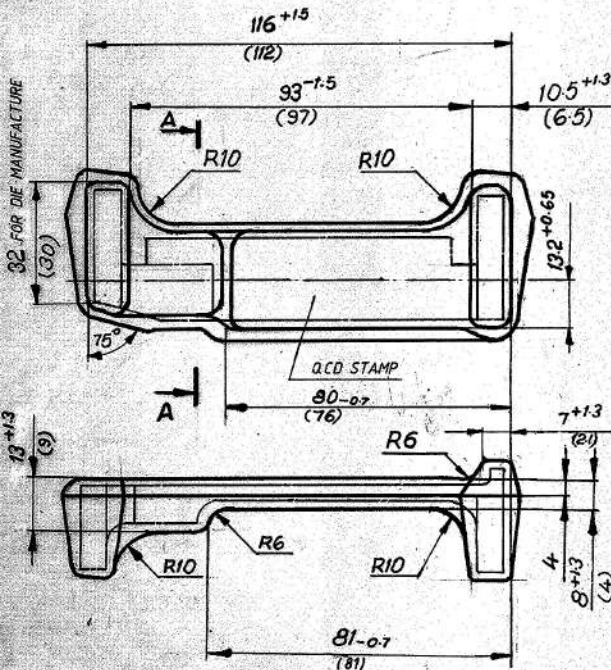

CHEMICAL COMPOSITION AND
MECHANICAL PROPERTIES
OF MATERIAL:- STEEL 45-2a

C	0.42 - 0.50
Si	0.17 - 0.37
Mn	0.5 - 0.80
Cr	0.25 MAX.
Ni	0.25 MAX.
S	0.040 MAX.
P	0.035 MAX.
Cu	0.25 MAX.
HARDNESS	BHN 255 MAX.
TENSILE STRENGTH	61 Kg/mm ²
ELONGATION	16 %
REDUCTION IN AREA	40 %
IMPACT STRENGTH	5 Kgf/cm ²
YIELD POINT	36 Kg/mm ²

NOTES :-

- DIMENSIONS ARE IN mm.
- FIRST ANGLE PROJECTION.
- SCALE:- 1:1
- FORGING OF GROUP II AS PER GOST 8479-70, HB 207 MAX.
- DRAFT ANGLE 7° UNLESS OTHERWISE SPECIFIED.
- UN-SPECIFIED RADII 2 R.
- FLASH REMAINDER UP TO 0.7 mm.
- WARPING UP TO 0.8 mm.
- DIE SHIFTING UP TO 0.5 mm.
- CONVENTIONAL CONTOUR AND DIMENSIONS GIVEN IN BRACKETS PERTAIN TO THE FINISHED PART.
- STAMP PART NO. AND Q.C.D STAMP ON THE FORGINGS.
- 5% OF A BATCH SHOULD BE CHECKED FOR HARDNESS AS PER GOST 8479-70.
- WEIGHT OF THE FORGING 0.375 Kgs.
- STAMP MELTING NO ON THE TAG.

...VETTED FOR MATERIAL ONLY

[Signature]
Principal Scientist (Quality Assurance)
Quality Assurance Officer,
For Senior Quality Assurance Officers,
Senior Quality Assurance Exec. (Process)
Truochirappalli-620016.

CHEMICAL COMPOSITION AND MECHANICAL PROPERTIES OF MATERIAL STEEL 45-2a		
C	0.42 - 0.50	ELONGATION - 19%
Si	0.17 - 0.37	REDUCTION IN AREA - 45 %
Mn	0.50 - 0.80	IMPACT STRENGTH - 6 Kg/mm ²
Cr	0.25 MAX.	YIELD POINT - 34 Kg/mm ²
Ni	0.25 MAX.	
R	0.035 MAX.	
S	0.04 MAX.	
Cu	0.25 MAX.	
HARDNESS	- BHN 255 MAX.	
TENSILE STRENGTH	- 58 Kg/mm ²	

HEAT-TREATMENT:-FORGINGS ARE NORMALIZED.
FOR HEAT-TREATMENT SCHEDULE REFER DRAWING
NO: M 881 SHEET NO: 1 TO 3 AND SHEET NO: 4 SL NO: 3

MATERIAL FOR INDIA:-
85-978-PT.1-1983 GR.000 H-50 (UNNARMALISED)
IS: 5517-1983, DESIGN 45C8 - (C)

COMPONENT DRG. NO. 6P11-2-5
BRACKET ROCKING BAR

DS.CAT No. 1005007335

MATERIAL:- STEEL 45-2a GOST 1050-76
ALTERNATE MATERIAL:- STEEL 40-2a GOST 1050-76

DRAWING PROVISIONAL

REDRAWN	CHECKED	APPROVED	I/C. D&DO	DIV.OFFICER
---------	---------	----------	-----------	-------------

ORDNANCE FACTORY, TRUOCHIRAPPALI-16	DRG. NO: 62 C 2105 200 BC3
--	-------------------------------