

42011  
7490312606

2

THIS DOCUMENT AND THE INFORMATION CONTAINED IN IT ARE PROPRIETARY AND CONFIDENTIAL TO OFT. NO PERSON OR ENTITY IS ALLOWED TO COPY, REPRODUCE, REPRODUCE OR PUBLISH ANY PART OF THIS DOCUMENT, NOR DISCLOSE ITS CONTENTS TO OTHERS, NOR MAKE ANY USE OF IT, NOR ALLOW OR ASSIST OTHERS TO MAKE ANY USE OF IT UNLESS BY THE PRIOR WRITTEN EXPRESS AUTHORIZATION OF OFT AND THEN ONLY TO THE EXTENT AUTHORIZED.  
COPYRIGHT © FT.

**NOTES:**

1. INTERPRET THIS DRAWING IAW ASME Y14.100M.
2. MATERIAL: CRES BAR TYPE 17-4PH PER AMS-5643. PURCHASED IN CONDITION H1150.
3. UNLESS OTHERWISE SPECIFIED, UNDEFINED MACHINED FILLET RADII SHALL BE 0.2...0.3.
4. DEBURR AND REMOVE SHARP EDGES, APPROX. 0.2X45 Deg.
5. GENERAL TOLERANSEC ACCORDING TO ISO 2768-m.
6. PASSIVATION TREATMENT PER AMS-2700 METHOD 1 TYPE 8.
7. BAKE PART AFTER PLATING WITHIN 3 HOURS PER AMS-2759/9 TABLE 1 FOR 3 HOURS MINIMUM AT 191°C.
8. QUALITY ASSURANCE PROVISIONS:
- 8.1. QUALITY ASSURANCE PROVISIONS FOR THIS ITEM PER RDMQD0012P.
- 8.2. MAJOR CHARACTERISTICS NRS 101 TO 103. PARENTHEICAL FIGURES ARE FOR REFERENCE ONLY.
9. PACKAGING AND PACKING:
10. THE FINISHED PART SHALL BE PRESERVED AND PACKAGED IN ACCORDANCE WITH MANUFACTURERS BEST COMMERCIAL PRACTICE.
11. IDENTIFY PER MIL-STD-130 PARA 4.1.B. BY LABELING ITS CONTAINER WITH THE PART NUMBER. CHARACTER MINIMUM TEXT HEIGHT 1.25 MM.

B

A



(WEIGHT APPROX.: 0.018 kg)

2

DWG NO: 077855A-00	
SHEET REV RECORD	
ALL SHEETS ARE THE SAME REVISION	

REV	ECO	DESCRIPTION	DATE	APVD
01		Freeze	01-Dec-13	
02		Freeze	07-Apr-14	M. Levin
03		Freeze	25-Jun-14	L. Goldstein
	T00095	Identical To Previous	09-Apr-18	L. Goldstein

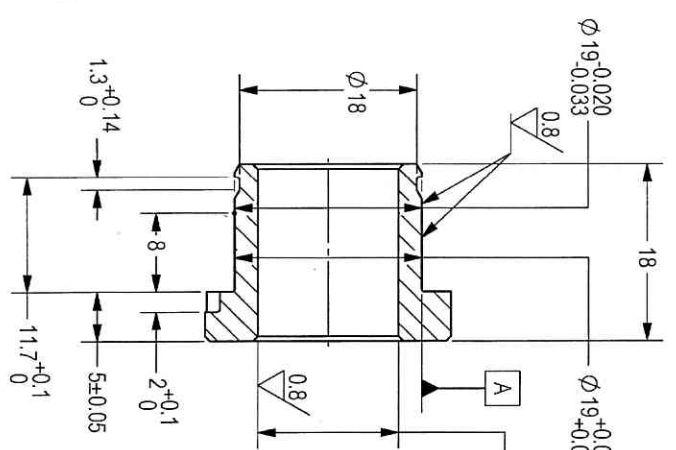

SECTION A-A

1.6 / (0.8)

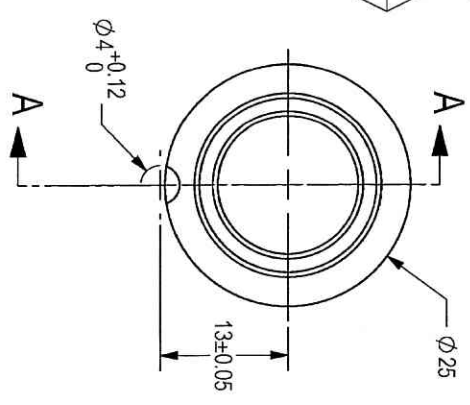

B

A

SEE ATTACHED MEDIA

UNLESS OTHERWISE SPECIFIED		DRAWN		SIGNATURE		DATE	
DIMENSIONS ARE IN MM PER ASME Y14.5M-1994		CHECKED		[Signature]		11/12	
TOLERANCES		ANGULAR		HOS/DDO		3/1/20	
SEE NOTE 5		SEE NOTE 5		OFFICER/PROD			
1st ANGLE PROJECTION		OFFICER/ID		OFFICER/ID			
PROJECT OFFICER		SURFACE TEXTURE IN Micro METER		OFFICER/ID		PLM Control	
PROJECT OFFICER [Signature]		SURFACE TEXTURE IN Micro METER		OFFICER/ID		PLM Control	
TITLE				ORDNANCE FACTORY			
BUSHING FRONT 1				TRUCHIRAPPALLI			
SCALE 2:1				FOR: CRADLE MOBILE ASSY			
CAGE CODE 2291A				OF: 12 TMM SRCG			
SIZE B				DWG NO 077855A-00			
AUTOMATED DRAWING (SW)				SHEET 1 OF 1			

30-11-2020

[Signature]

ORDNANCE FACTORY TRUCHIRAPPALLI