

नियंत्रित प्रति सं. 2
CONTROLLED COPY NO.
 Certified True Copy as
 on 27.11.06 ...
[Signature]
 Ordnance Factory Delta Road

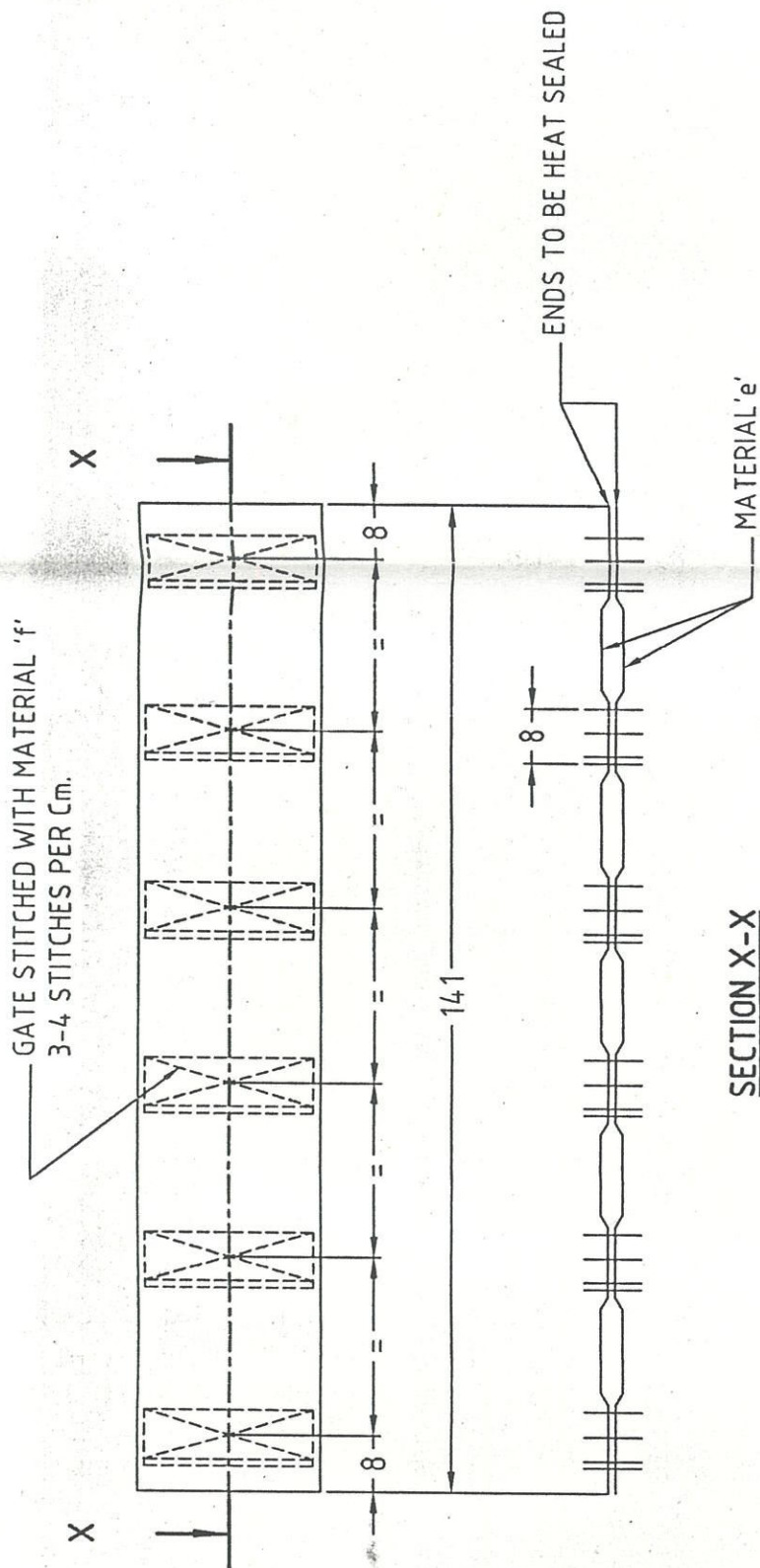

LIST OF MATERIALS

SRL	NOMENCLATURE	SPECN./DRG.No.
e	WEBBING NYLON, 25.4 mm U/D	ADRDE/SPECN/1983/11
f	THREAD SEWING NYLON LIGHT, OG/UD VARIETY No.13 (BS 40N)	IS:4229-1978

NOTE:- SPECN/DRG No. MENTIONED IN THE 'LIST OF MATERIALS' UNDER THE COLUMN SPECN./DRG.No. SHALL BE TAKEN AS A REFERENCES TO THE LATEST SPECN./DRG.No.

1-OFF

Tracee & checked
(R-0100)

DESIGN AUTHORITY ADRDE, AGRA	DRAWING CONVENTIONS CONFORM TO IS:696 DIMNS. ARE IN mm UNLESS OTHERWISE STATED	GEN. TOL:-	DRAWING NAME: PARACHUTE SYSTEM FOR 84 mm CARL GUSTAF ILLUMINATING AMMUNITION (LOOP BAND)
	SCALE:- 1:1	SHEET NO :- 7 OF 9	REF: ADRDE/543-A3 (b)
TRACED WITH ADRDE DRAWING NO. ADRDE/543-A3 (5)			

नियंत्रित प्रति सं.
CONTROLLED COPY NO. 2

Certified in the City as
on 27/11/06
Jyoti Bhandari
Ordnance Factory Delhi Road

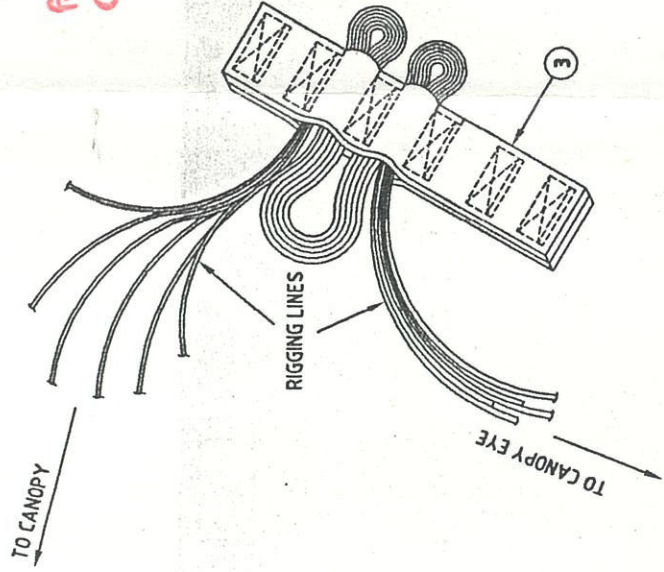

VIEW SHOWING STOWAGE OF RIGGING LINES IN THE LOOP BAND

SCHEDULE

SRL.	DETAIL No.	SHEET No.	NOMENCLATURE	No. OFF	SPECN/DRG.No.
1	-	1-2	GENERAL, ASSEMBLY	-	ADRDE/543(b)
2	1	3-5	CANOPY	1	ADRDE/543-A-1(a)
3	2	6	RISER	1	ADRDE/543-A-2(a)
4	3	7	LOOP - BAND	1	ADRDE/543-A-3(a)
5	4	8	STEEL RING	1	ADRDE/543-A-1/SA-1
6	5	9	WIRE ROPE	1	ADRDE/543-A-2/SA-1

ROWS OF DOUBLE ZIG-ZAG STITCHINGS WITH MATERIAL 'f' 3-4 STITCHES PER Cm TO BE DONE AFTER PASSING RISER END THROUGH CANOPY EYE.

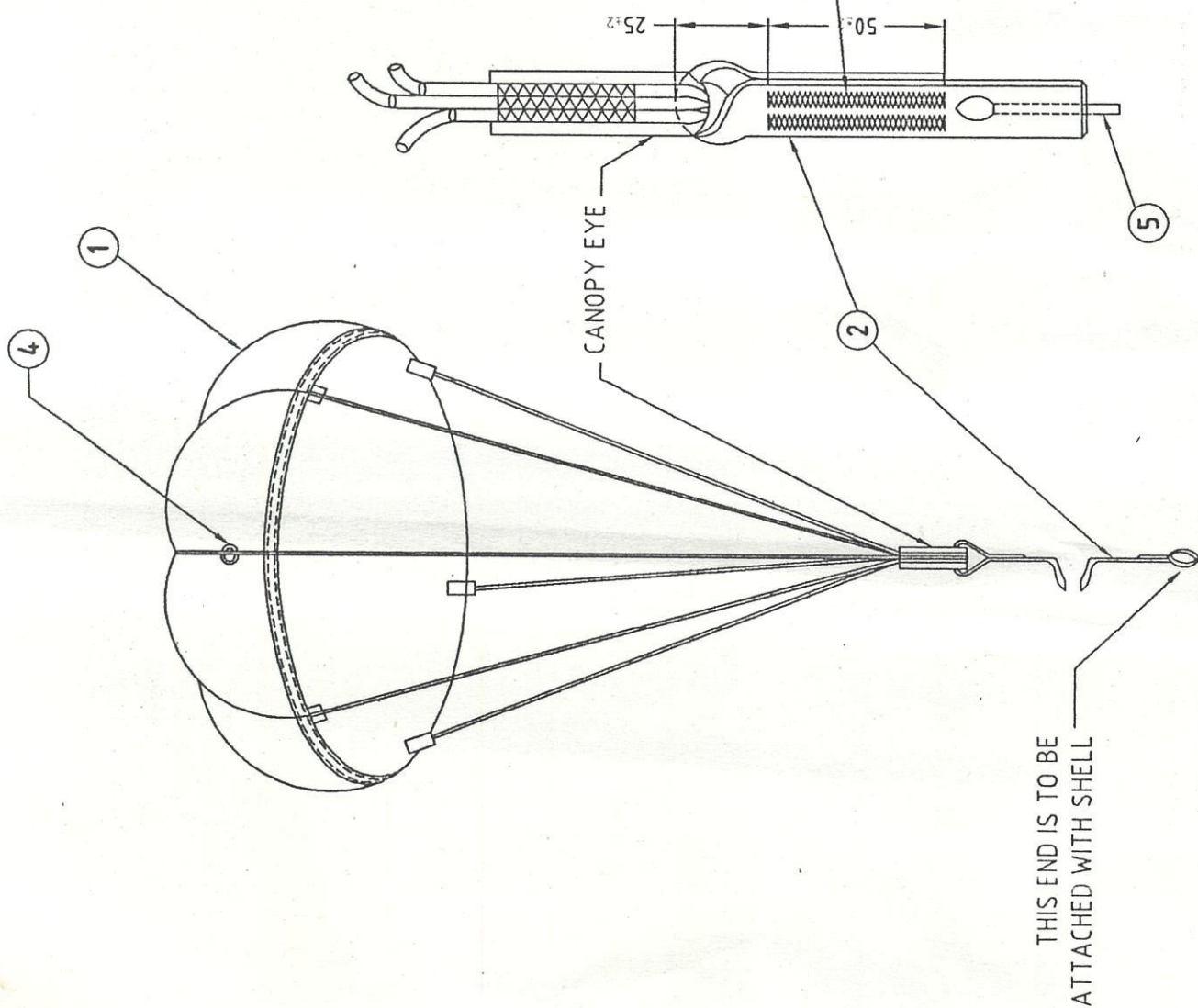

VIEW SHOWING ATTACHMENT OF CANOPY EYE WITH RISER LOOP

DRAWING CONVENTIONS CONFORM TO IS:696 DIMNS. ARE IN mm UNLESS OTHERWISE STATED

WORKING TOLERANCES ON DIMNS :-AS SPECIFIED

SCALE:- NTS

SHEET NO :- 1 OF 9

REF: ADRDE/543 (b)

TRACED WITH ADRDE DRAWING HC. ADRDE/543 (b)

DESIGN AUTHORITY

ADRDE, AGRA

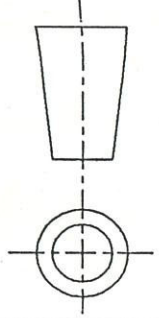

Free Sheet
Jyoti Bhandari
27/11/06

GENERAL ASSEMBLY

DRAWING NAME: PARACHUTE SYSTEM FOR
84 mm CARL GUSTAF
ILLUMINATING AMMUNITION
(GENERAL ASSEMBLY)

निम्नलिखित प्रतिकोपि
 COPIED COPY NO. 2

LIST OF MATERIALS/COMPONENTS

SRL.	NOMENCLATURE	NO. OF COMP	DETAIL-REF	SPECN./DRG.No.
a	FABRIC NYLON, 75 G, U/D			ADRDE/SPECN/1980/5(a)
b	TAPE TUBULAR NYLON BRAIDED, 3.5mm U/D			ADRDE/SPECN/1981/6
c	TAPE TUBULAR NYLON, 14mm U/D			ADRDE/SPECN/1981/6
d	TAPE NYLON, 19mm, U/D			ADRDE/BP/3(a)
e	WEBBING NYLON, 25.4 mm,U/D			ADRDE/SPECN/1983/11
f	THREAD SEWING NYLON LIGHT. OG/UD, V.NO. L3 (BL=40 N)			IS:4-229-1978
g	INK BLACK			IND/SL SERIES
h	STEEL RING			ADRDE/543-A-1/SA-1
j	WIRE ROPE			ADRDE/543-A-2/SA-1

DESCRIPTION :- THE PARACHUTE IS USED IN THE 84mm ILLUMINATING ROUND FFV545. THE PARACHUTE MAINLY CONSISTS OF CANOPY RIGGING LINES AND RISER. ITS PURPOSE IS TO GIVE THE ILLUMINATING ASSEMBLY A SUITABLE RATE OF DESCENT AFTER BURST.

PACKING :- ONE PARACHUTE WILL BE PACKED IN A POLYTHENE BAG OF SUITABLE SIZE. AN APPROPRIATE NUMBER OF SUCH BAGS SHALL BE PLACED IN A CCBC OF SIZE 38 Cm X 38 Cm X 45.5 Cm. THE EMPTY SPACES IF ANY, IN THE CCBC SHALL BE FILLED WITH CUSHIONING MATERIAL TO AVOID DAMAGE IN TRANSIT. THE FLAPS OF THE CCBC SHALL BE SECURED BY LACING TWINE JUTE 3 PLY THROUGH EYELETS PROVIDED FOR THIS PURPOSE.

- BEFORE DESPATCH EACH BOX SHALL BE LEGIBLY AND INDELIBLY MARKED WITH THE FOLLOWING:-
- (i) NOMENCLATURE AND CAT.NO. OF THE STORE.
 - (ii) QUANTITY PACKED IN EACH BOX.
 - (iii) SRL.NO. OF THE BOX.
 - (iv) MONTH & YEAR OF THE PACKING.
 - (v) NAME & TRADEMARK OF THE MANUFACTURE.
 - (vi) MASS OF THE BOX IN Kg.
 - (vii) NAME AND ADDRESS OF CONSIGNEE.
 - (viii) NAME AND ADDRESS OF CONSIGNOR.
 - (ix) INSPECTION NOTE NO. AND DATE.

NOTE:- SPECN/DRG No. MENTIONED IN THE 'LIST OF MATERIALS/COMPONENTS' UNDER THE COLUMN SPECN./DRG.No. SHALL BE TAKEN AS A REFERENCES TO THE LATEST ISSUE OF THAT SPECN./DRG.No.

Certified True Copy as
 on 22/11/06
 J. P. Singh
 Ordnance Factory Delhi Road

Traced by
 (S. P. Singh)

DESIGN AUTHORITY ADRDE, AGRA	DRAWING NAME: PARACHUTE SYSTEM FOR 84 mm CARL GUSTAF ILLUMINATING AMMUNITION (GENERAL ASSEMBLY)
SHEET NO. - 2 OF 9	REF: ADRDE/543 (b)
SCALE - NTS	TRACED WITH ADRDE DRAWING NO. ADRDE/543 (c)

नियंत्रित प्रतिलिपि
CONTROLLED COPY NO. 2

LIST OF MATERIAL/COMPONENTS

SRL	NOMENCLATURE	No.OFF COMP.	SPECN./DRG.No.
a	FABRIC NYLON, 75 g. U/D	-	ADRDE/SPECN/1980/5(a)
b	TAPE TUBULAR NYLON BRAIDED, 3.5 mm U/D	-	ADRDE/SPECN/1981/6
d	TAPE NYLON, 19 mm, U/D	-	ADRDE/BP/3(a)
f	THREAD SEWING NYLON LIGHT, OG/UD VARIETY NO. L3(BL-40 N)	-	IS:4229-1978
g	INK BLACK	-	IND/SL SERIES
h	STEEL RING	1	ADRDE/543-A-1/SA-1

NOTE:- SPECN/DRG No. MENTIONED IN THE 'LIST OF MATERIALS/COMP. UNDER THE COLUMN SPECN./DRG.No. SHALL BE TAKEN AS A REFERENCE TO THE LATEST ISSUE OF THAT SPECN./DRG.No.

DETAIL INDEX

DETAIL No.	SHEET No.	NOMENCLATURE	No.OFF
1	3	CANOPY, ASSEMBLY	1
-	4	CANOPY(OUTER FLAT VIEW)	-
-	5	CANOPY, CUTTING TEMPLATE	2

Certified True Copy as on 07.11.06
(Signature)
 Ordinance Factory, Dabra Road

DRAWING NAME: PARACHUTE SYSTEM FOR 84 mm CARL GUSTAF ILLUMINATING AMMUNITION (CANOPY)

WORKING TOLERANCES ON DIMS :- LESS THAN 50 mm - ±2mm, 51 mm UPTO 250 mm - ±3mm, EXCEPT WHERE OTHERWISE SPECIFIED

DRAWING CONVENTIONS CONFORM TO IS:696 DIMS. ARE IN mm UNLESS OTHERWISE STATED

SCALE:- NTS & 1:1

SHEET NO :- 3 OF 9

REF: ADRDE/543-A-1 (b)

DESIGN AUTHORITY
ADRDE, AGRA

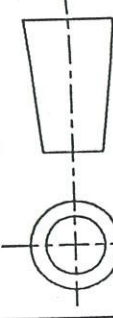

Traced & checked
(Signature)
 02/05/06

ASSEMBLY

2-ROWS OF DOUBLE ZIG-ZAG STITCHINGS WITH MATERIAL 'f', 3-4 STITCHES PER Cm.

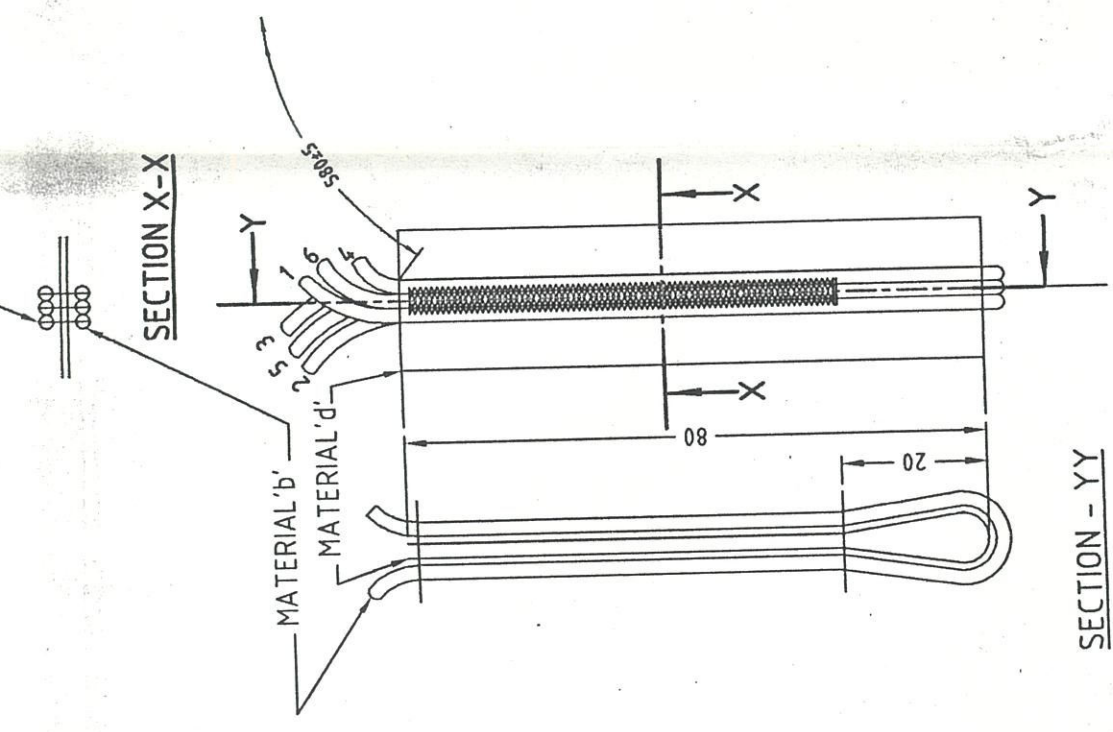

SECTION - YY

DETAIL OF FORMATION OF EYE (MARKED - 'P')

SCALE: 1:1

PLACE FOR MARKING NOMENCLATURE OF THE STORE, CAT.NO. MANUFACTURER'S NAME OR RECOGNISED TRADE MARK, MONTH & YEAR OF MANUFACTURE AND INSPECTOR'S STAMP WITH INK MATERIAL 'g'.

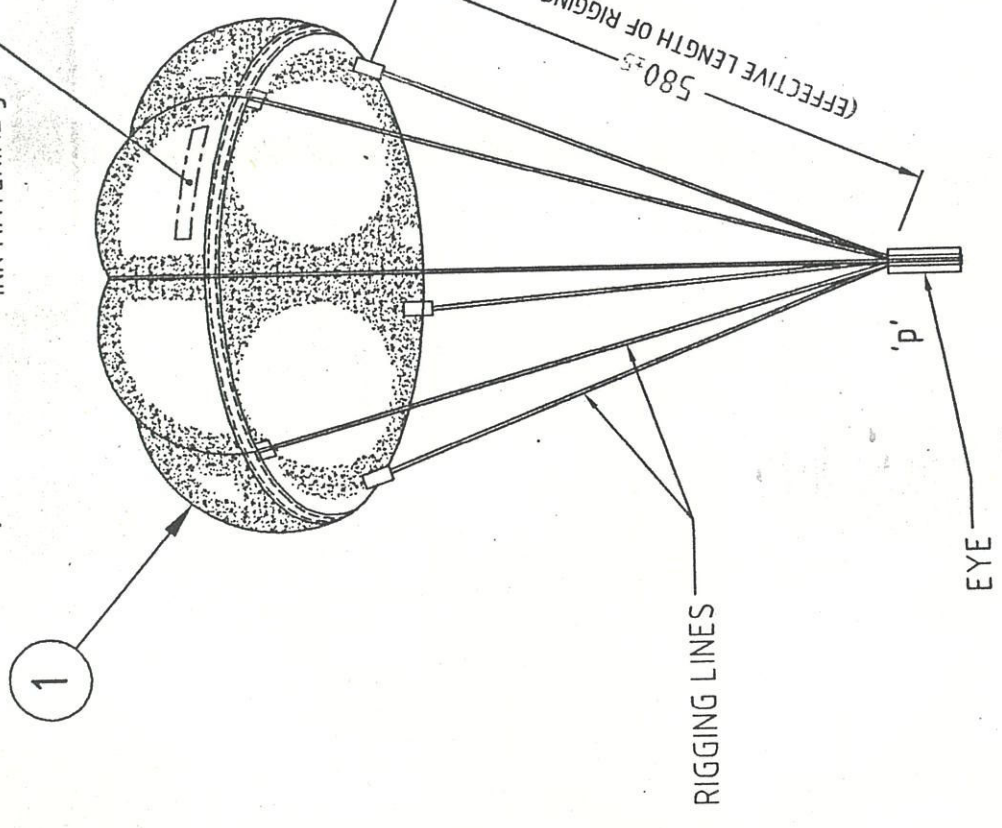

Handwritten notes and signatures at the top right of the page.

नियंत्रित प्रतिलिपि सं. 2
CONTROLLED COPY NO.

Certified True Copy as
on 27/11/06...
Dr. P. S. Singh
Ordinance Factory Dehra Doon

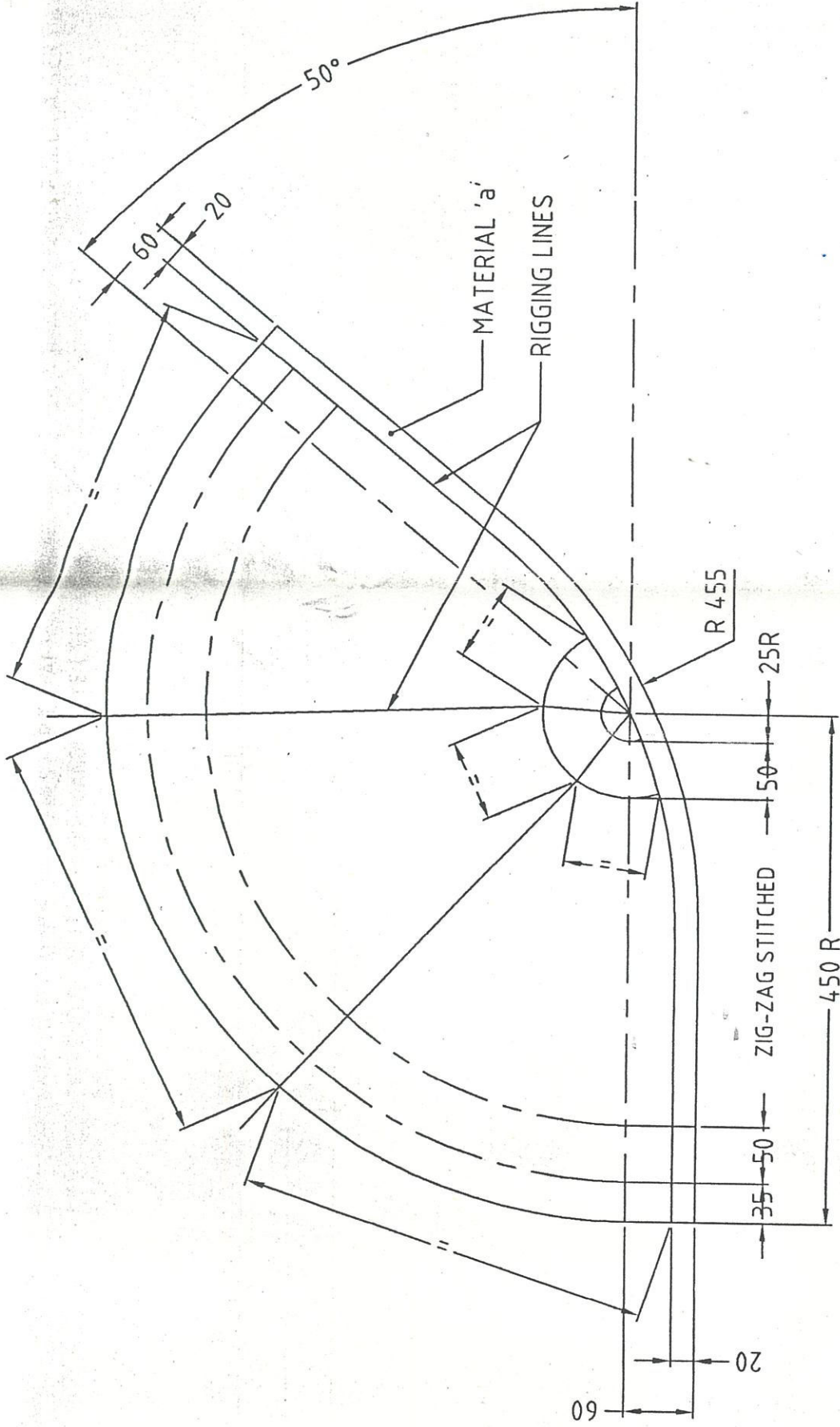

CANOPY, CUTTING TEMPLATE OF CANOPY

2-OFF

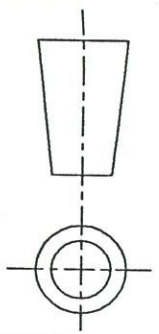
DESIGN AUTHORITY ADRDE, AGRA 	DRAWING NAME: PARACHUTE SYSTEM FOR 84 mm CARL GUSTAF ILLUMINATING AMMUNITION (CANOPY)
DRAWING CONVENTIONS CONFORM TO IS:695 DIMNS. ARE IN MM UNLESS OTHERWISE STATED	WORKING TOLERANCES ON DIMNS. --LESS THAN 50 mm-- ± 2 mm, 51 mm UPTO 250 mm-- ± 3 mm, 251 mm UPTO 750 mm-- ± 6 mm,
SCALE:- 1:5 SHEET NO:- 5 OF 9	REF: ADRDE/543-A3 - A-1 (b)
TRACED WITH ADRDE/DRAWING HO. ADRDE/543-A3 - A-1 - (b)	

Traced & checked by
 (Signature)
 ADRDE, AGRA

नियंत्रित प्रती सं. 2
CONTROLLED COPY NO.
 Certified True Copy as
 on 27/11/2006
[Signature]
 Ordnance Factory Dehra Doon

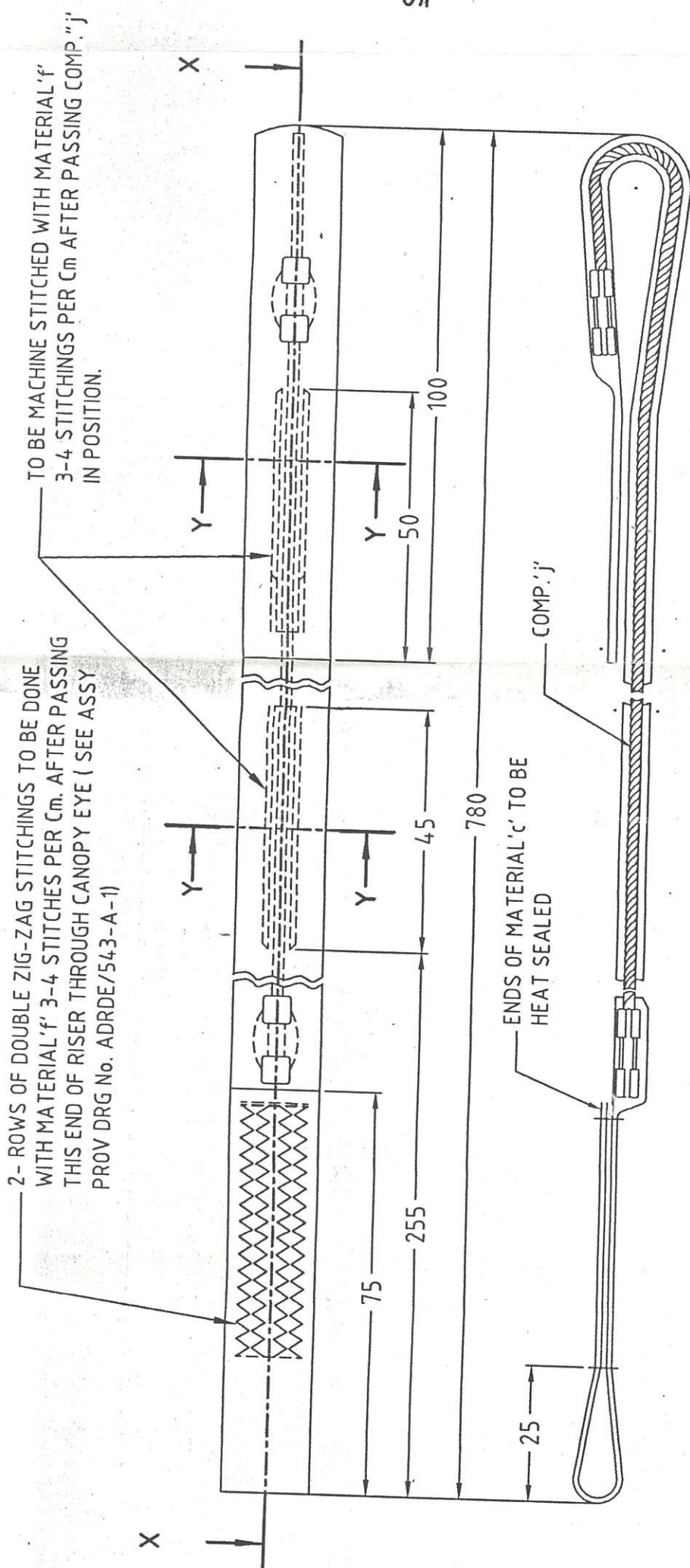

NOTE:- SPECN/DRG No. MENTIONED IN THE 'LIST OF MATERIALS' UNDER THE COLUMN SPECN./DRG.No. SHALL BE TAKEN AS A REFERENCES TO THE LATEST ISSUE OF THAT SPECN./DRG.No.

LIST OF MATERIAL/COMPONENTS

SRL	NOMENCLATURE	No.OFF COMP.	SPECN./DRG.No.
c	TAPE TUBULAR NYLON, 14 mm U/D	-	ADRDE/SPECN/1981/6
f	THREAD SEWING NYLON LIGHT OG/UD VARIETY No.L3 (BS 40N)	-	IS:4229-1978
g	INK BLACK	-	IND/SL SERIES
j	WIRE ROPE	1	ADRDE/543-A-2/SA-1

ASSEMBLY

DESIGN AUTHORITY ADRDE, AGRA	DRAWING CONVENTIONS CONFORM TO IS:696 DIMS. ARE IN mm UNLESS OTHERWISE STATED	WORKING TOLERANCES ON DIMS --LESS THAN 50 mm - ±2mm, 51 mm UPTO 250 mm - ± 3mm, 251 mm UPTO 750 mm - 6mm, ABOVE 751 mm UPTO 1520 mm - ±10mm,	DRAWING NAME: PARACHUTE SYSTEM FOR 84 mm CARL GUSTAF ILLUMINATING AMMUNITION (RISER)
	SCALE:- 1:1	SHEET NO :- 6 OF 9	REF: ADRDE/543-A2 (b)
TRACED WITH ADRDE DRAWING NO. ADRDE/543-A2 (b)			

[Handwritten signatures and initials]
 27/11/2006

नियंत्रित प्रति सं. **2**
CONTROLLED COPY NO.

Certified True Copy as
 on 27.11.06 ...
[Signature]
 Ordnance Factory Delta Kood

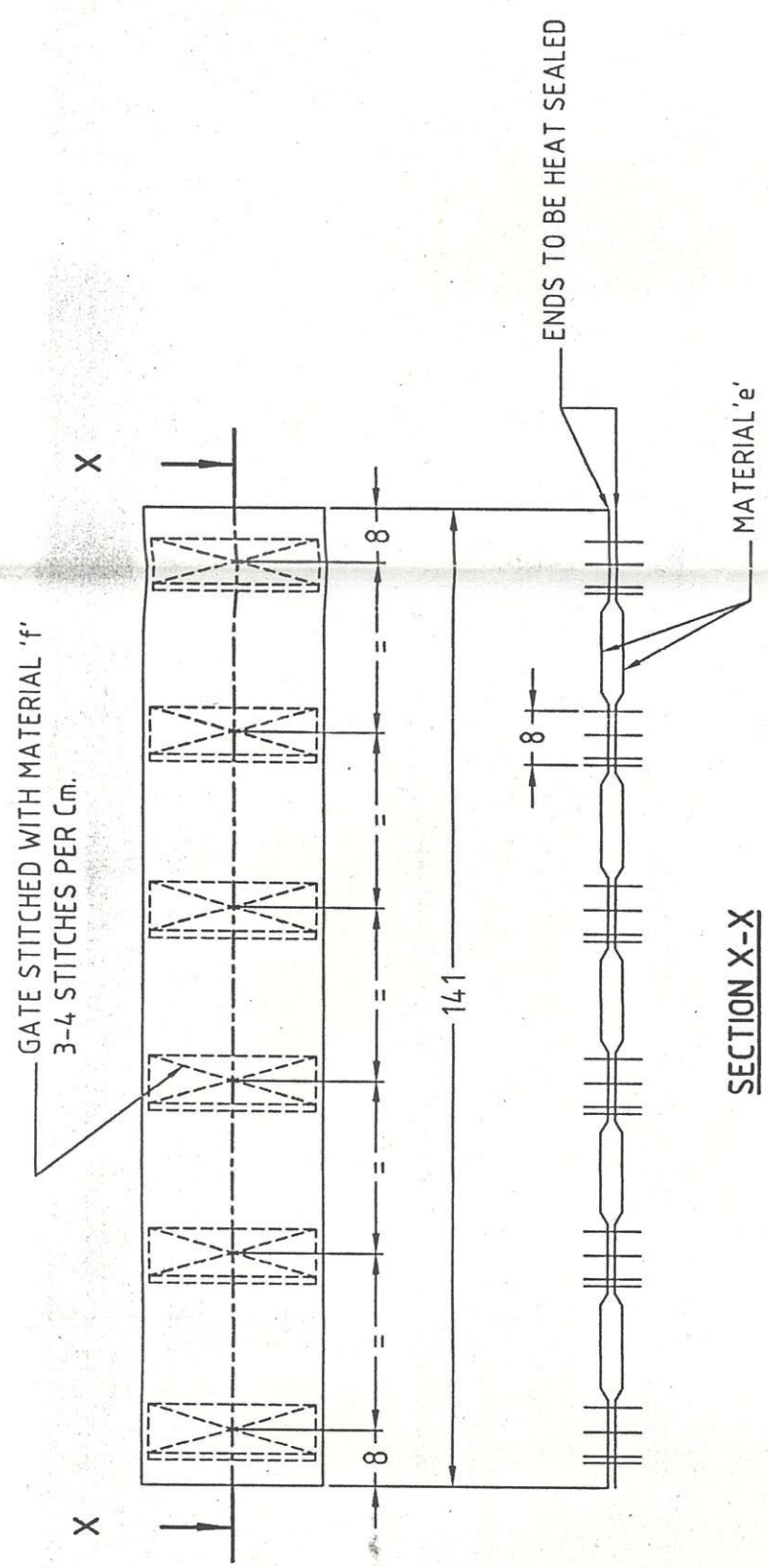

LIST OF MATERIALS

SRL	NOMENCLATURE	SPECN./DRG.No.
e	WEBBING NYLON, 25.4 mm U/D	ADRDE/SPECN/1983/11
f	THREAD SEWING NYLON LIGHT, OG/UD VARIETY No.13 (BS 40N)	IS:4229-1978

NOTE:- SPECN/DRG No. MENTIONED IN THE 'LIST OF MATERIALS' UNDER THE COLUMN SPECN./DRG.No. SHALL BE TAKEN AS A REFERENCES TO THE LATEST SPECN./DRG.No.

1-OFF

Tracee & checked
[Signature]
 27.11.06

DESIGN AUTHORITY	ADRDE, AGRA	DRAWING CONVENTIONS CONFORM TO IS:696 DIMNS. ARE IN mm UNLESS OTHERWISE STATED	GEN. TOL:-	DRAWING NAME:
		SCALE:- 1:1	SHEET NO :- 7 OF 9	PARACHUTE SYSTEM FOR 84 mm CARL GUSTAF ILLUMINATING AMMUNITION (LOOP BAND)
		TRACED WITH ADRDE DRAWING NO. ADRDE/543-A3 (5)		REF: ADRDE/543-A3 (b)

BOTH ENDS OF THE WIRE ROPE TO BE HELD FIRMLY BY PRESSING SUITABLE COPPER FERRULE CUT ROPE ENDS FLUSH TO THE FERRULE ENDS.

GALVANISED STEEL WIRE ROPE PREFORMED, ϕ 2 MM, 7X7 CONSTRUCTION, MIN. BREAKING LOAD 2450 N (250 KG)

THE FERRULES HELD IN SUITABLE GRIPS WHEN SUBJECTED TO LOAD OF 200 N (20 Kg) IN THE DIRECTION SHOWN, SHALL SHOW NO. SIGN OF SLIPPAGE/DAMAGE.

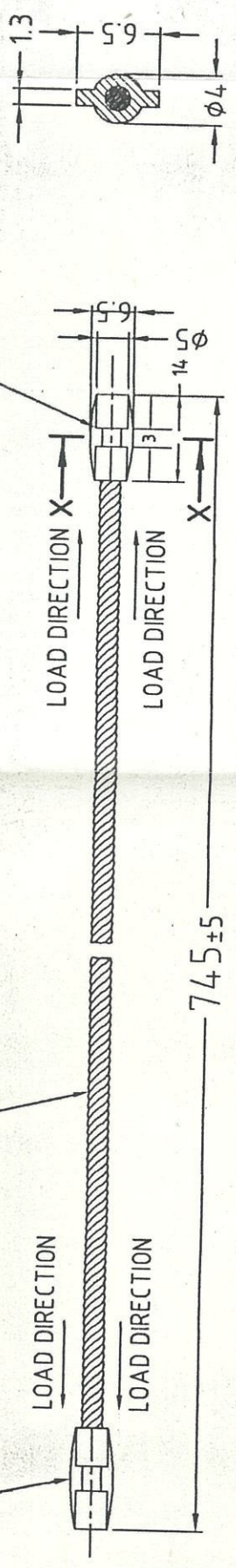

SECTION - XX
SCALE : 2:1

Certified True Copy as on 27/11/06
[Signature]
28/10/06

नियंत्रित प्रतिसं.
CONTROLLED COPY NO. 2

PACKING:- EACH WIRE ROPE SHALL BE ROLLED TO A COIL OF SUITABLE DIAMETER. EACH COIL SHALL BE PUT IN A POLYTHENE BAG AND SEALED 20 SUCH BAGS BE PACKED IN A SUITABLE CARTON. 20 SUCH CARTONS SHALL BE PACKED IN A CWP DULY LINED WITH PAPER PACKING WATER PROOF. ONE SAMPLE IN EACH CARTON SHALL BE IDENTIFIED BY A LABEL SHOWING THE NOMENCLATURE OF THE STORE AND YEAR OF MANUFACTURE. EACH CARTON SHALL BE MARKED WITH THE INITIALS OF THE MANUFACTURER BEFORE DESPATCH. EACH PACKING CASE SHALL BE LEGIBLY AND INDELIBLY MARKED WITH THE FOLLOWING DETAILS:-

- (i) NOMENCLATURE, CAT NO. OF THE STORE AND THE YEAR OF MANUFACTURE.
- (ii) TOTAL NO. OF THE PACKING CASES AND THE NO. OF THE INDIVIDUAL PACKING CASE IN A CONSIGNMENT.
- (iii) NO. OF CARTONS IN EACH PACKING CASE AND THE QUANTITY IN EACH CARTON.
- (iv) MASS OF THE PACKING CASE IN Kg.
- (v) ADDRESS OF THE CONSIGNEE.
- (vi) ADDRESS OF THE CONSIGNOR.

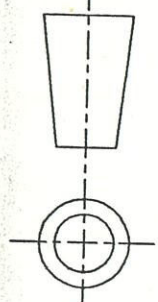
DESIGN AUTHORITY ADRDE, AGRA 	DRAWING CONVENTIONS CONFORM TO IS:696 DIMNS. ARE IN mm UNLESS OTHERWISE STATED SCALE:- 1:1 & 2:1	GEN TOL:- ±0.2 MM UNLESS OTHERWISE SPECIFIED	DRAWING NAME: PARACHUTE SYSTEM FOR 84 mm CARL GUSTAF ILLUMINATING AMMUNITION (WIRE ROPE) REF: ADRDE/543-A-2/SA-1(b)
TRACED WITH ADRDE DRAWING NO. ADRDE/543-A-2/SA-1 (b)		SHEET NO :- 9 OF 9	REF: ADRDE/543-A-2/SA-1(b)

Prepared by Chandra Mohan
[Signature]
(R. P. Singh)