

TRIPPLICATE  
T-905.

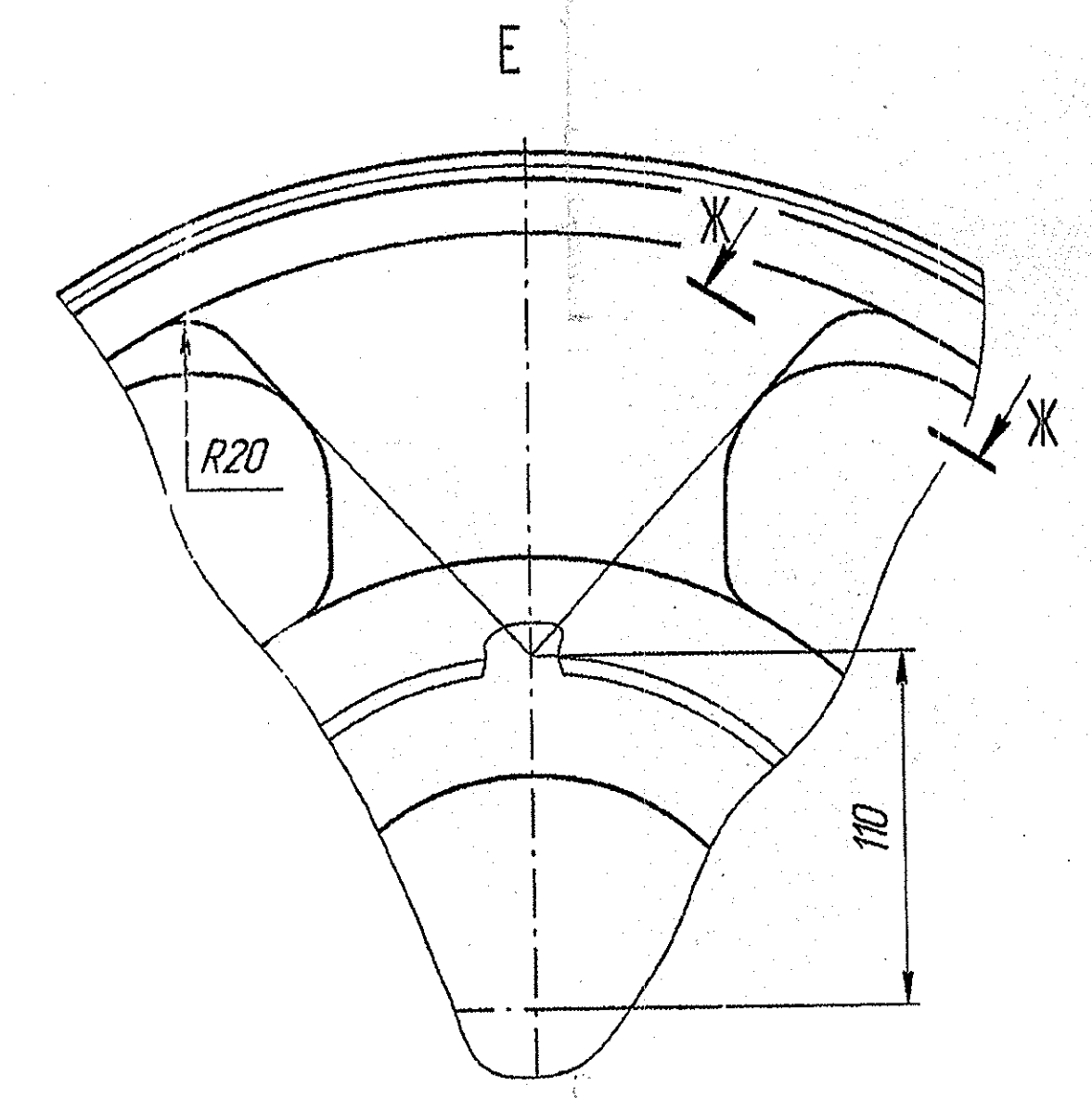

1. GRADE OF STEEL HEAT TREATMENT METHOD OF ACCEPTANCE AND TESTING SHOULD COMPLY WITH THE LIST OF COMPONENT MADE OUT OF SPECIAL STEEL MEDIUM HARDNESS.
2. REQUIREMENTS FOR CASTING SHOULD COMPLY WITH 172TY5.
3. ACCURACY OF CASTING 11-0-0-10 GOST 26645-85.
4. EXTERNAL DRAFT UP TO 1:20.
5. UNSPECIFIED RADI 5MM.
6. DATUM SURFACE SHOULD BE CLEAN.
7. MARK THE GRADE OF STEEL MELT No, DRAWING No OF COMPONENT.
8. UNEVENNESS CUT RAISER  $^{+5}_{-3}$  MM.
9. DIMENSION FOR REFERENCE.
10. CASTING WEIGHT 70.2 KG.
11. SCALES 1:2.

B-B (1:1) ○

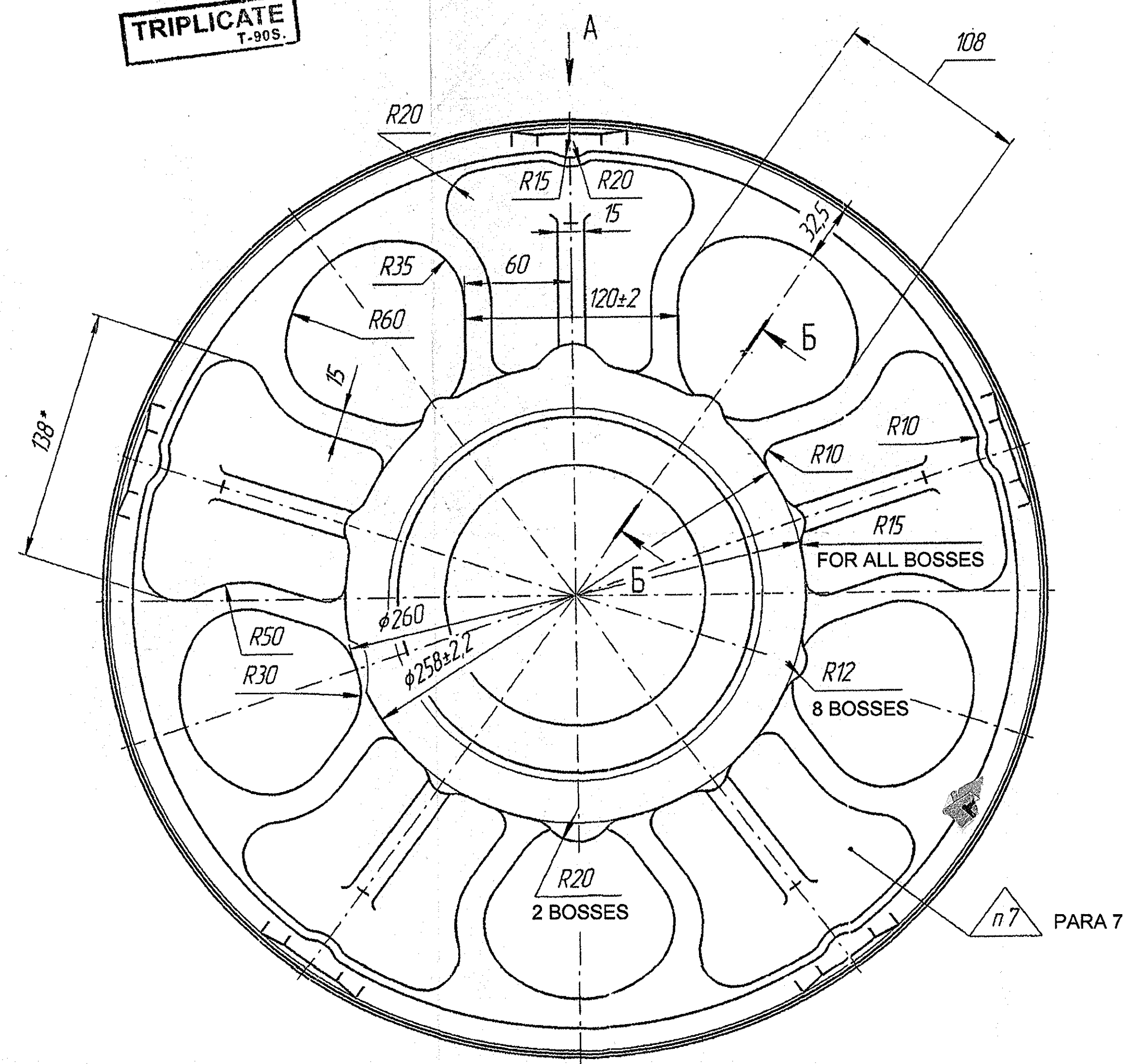
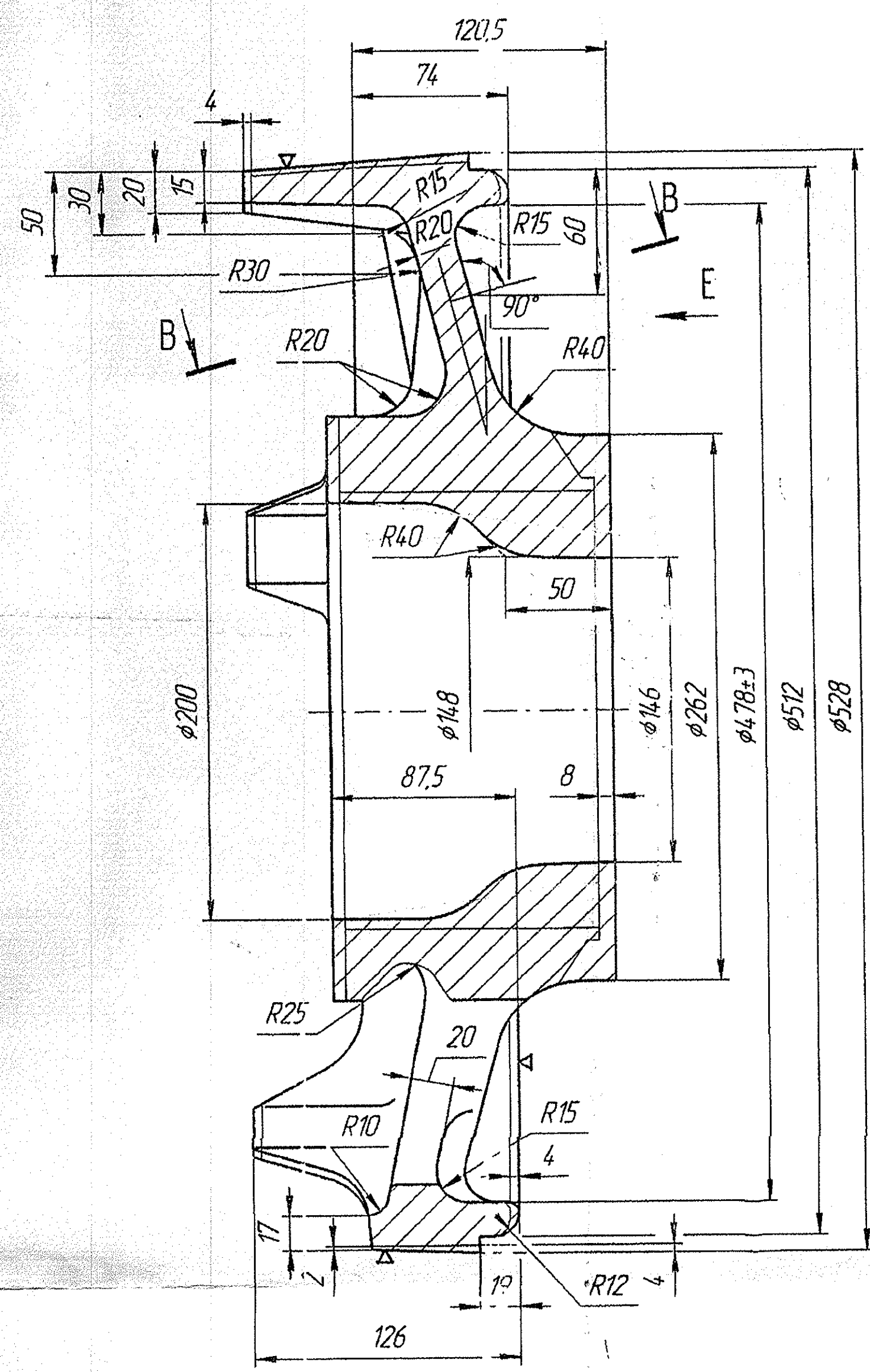
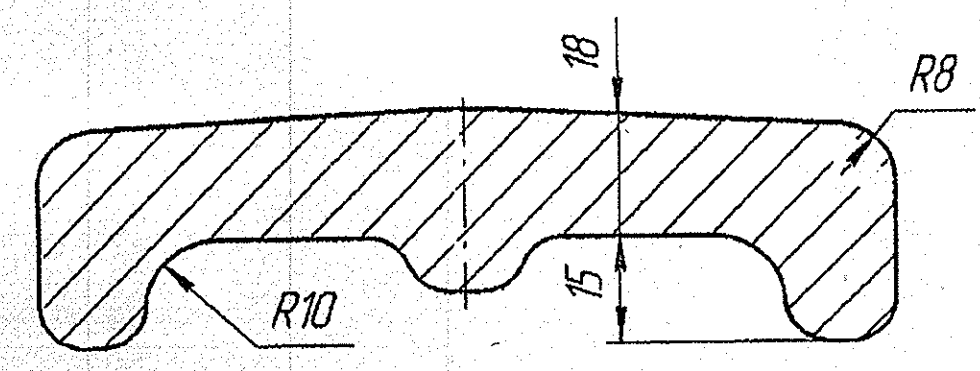

B-5 (1:1) ○

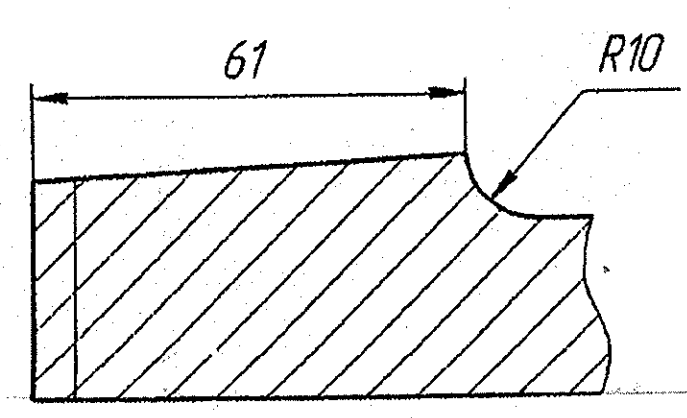

A Q

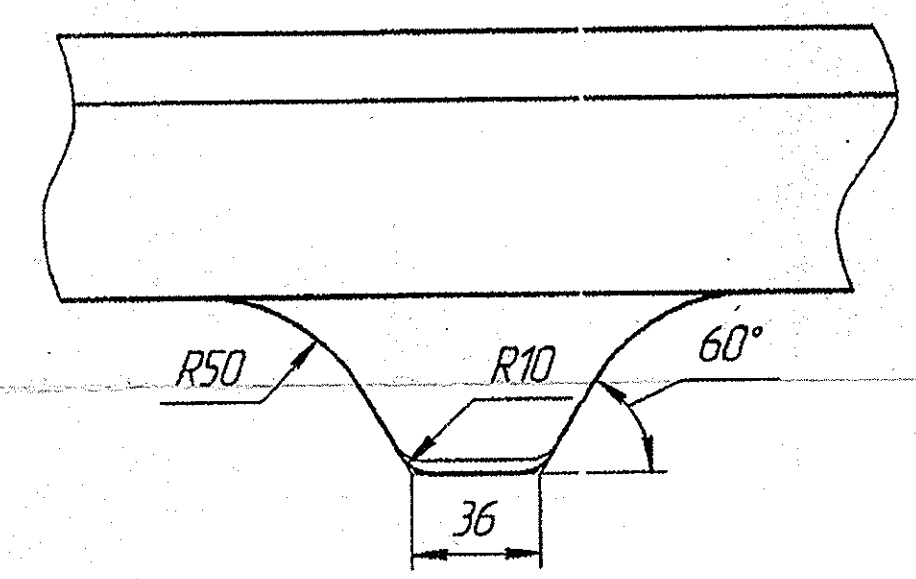

X-X (1:1) ○

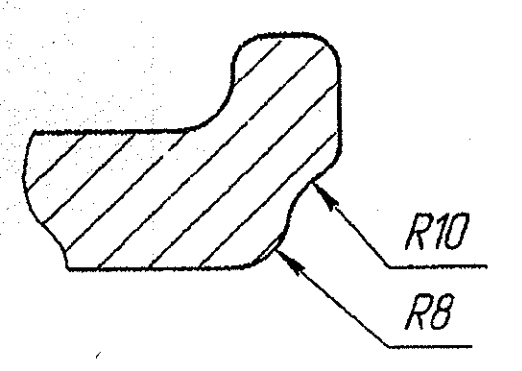

Approved  
JRM/RG  
15/12

MATERIAL		CASTING WT.	T 90
11-0-0-10 GOST 26645-85		70.2 KG	
ALT. MATERIAL	HAMMER	SCALE	
		1:2	
DRAWN	CHECKED	APPROVED	
DRAWING NO. 172-56-0085 / C			
NOMENCLATURE: EXTERNAL DISK			
HEAVY VEHICLES FACTORY AVADI, CHENNAI			

RC