

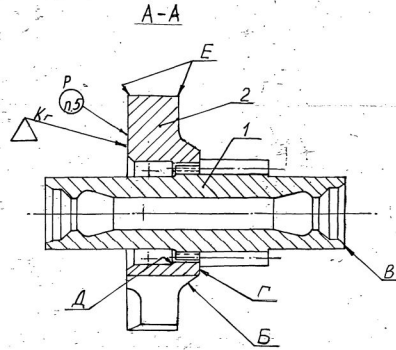

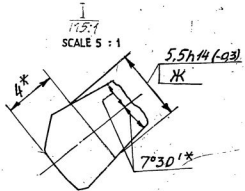

CB 3338-410-3

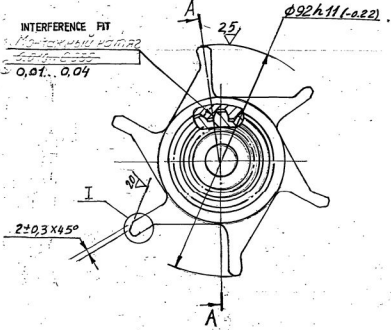

TECHNICAL REQUIREMENTS IN RUSSIAN

1. Балансировать статически до безразличного состояния, металл снимать не более чем с 33 первых в местах Е фаской не более 3,5 мм под углом $(45 \pm 5)^\circ$.
2. После балансировки на поверхностях Б и В нанести метку шероховатости против зуба шестерни.
3. Трещины на поверхностях Г и Д поводка не допускаются, проверку производить на магнитном дефектоскопе по ТТ УВ-17.
4. Допускается увеличение размера Ж до 5,7 мм.
5. Маркировать гравированием порядковый номер обратной единицы.
6. Размеры для построения мерительного инструмента.
7. Детали поз 1 и поз 2 устанавливать одноименных групп.
8. Сборочную единицу сдавать с паспортом.

TECHNICAL REQUIREMENTS - TRANSLATED

1. TO BE BALANCED STATICALLY TILL EQUILIBRIUM STATE IS OBTAINED, THE METAL SHOULD BE REMOVED FROM NOT MORE THAN ON 3 BLADES IN PLACES 'E' BY CHAMFER 3.5 mm, $(45 \pm 5)^\circ$.
2. AFTER BALANCING IN THE PLACES MARKED Б AND В THE PAIRING MARK SHOULD BE PUT AGAINST A TOOTH OF GEAR.
3. CRACKS ON SURFACES Г AND Д, OF GUIDE ARE NOT ALLOWED, TO BE CHECKED ON MAGNETIC FIELD FLAW DETECTOR AS PER TTUB-17.
4. DIMENSION Ж MAY BE INCREASED UP TO 5.7 mm.
5. SERIAL NUMBER OF ASSEMBLY UNIT IS TO BE MARKED BY ETCHING.
6. * DIMENSIONS FOR CONSTRUCTION OF GAUGE.
7. COMPONENTS 1 AND 2 OF THE SAME GROUP ARE TO BE INSTALLED.
8. THE UNIT TO BE ACCEPTED SHOULD BE ACCOMPANIED BY CERTIFICATE.

PILOT SAMPLE SHOULD BE APPROVED BY A H S P BEFORE BULK PRODUCTION.

EST. MASS TO BE STAMPED OR MARKED WHERE INDICATED THUS: **0.885 Kg** (LETTERS)

ALL SHARP EDGES AND CORNERS TO BE REMOVED UNLESS OTHERWISE STATED. MATCHED CORNERS TO HAVE R. OUTSIDE R IN-WIDE EDWARDS CHAMFERS ARE IMPOSSIBLE.

812 16883-619 7 15016883-619 812 16883-619	EST. MASS TO BE STAMPED OR MARKED WHERE INDICATED THUS: 0.885 Kg (LETTERS) ALL SHARP EDGES AND CORNERS TO BE REMOVED UNLESS OTHERWISE STATED. MATCHED CORNERS TO HAVE R. OUTSIDE R IN-WIDE EDWARDS CHAMFERS ARE IMPOSSIBLE.	PER: <i>S. B. B.</i> CD: <i>S. B. B.</i> APD: <i>S. B. B.</i> DATE: 12-7-88 SCALE: 1:1 DIMENSIONS IN mm UNLESS OTHERWISE STATED. ALL THREADS CONFORM TO	MATERIAL: - USED ON: CB 3338-412-2 CONTROLLERATE OF QUALITY ASSURANCE "HEAVY" VEHICLES A V A D I TITLE: ASSY. TRAIN SMALL GEAR D S CAT NUMBER:
A 12-1-96 AUTHY NOTN NO. BK. 82-87 ISSUE / DATE NATURE OF AMENDMENTS	DRAWING NUMBER CB 3338-410-3	A-9 50	



