

DRAWING NO.
172.40.328/F

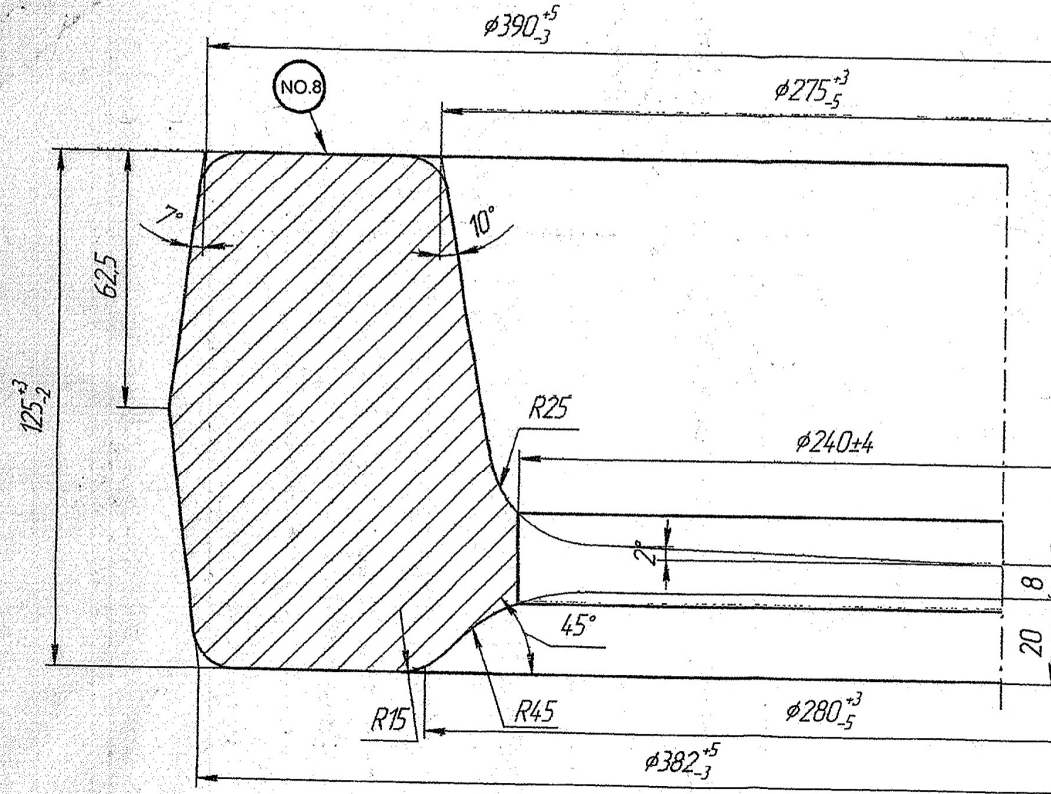

TECHNICAL REQUIREMENTS

01. SURFACE DEFECTS SHOULD BE WITHIN TOLERANCE LIMITS.
02. IMPRESSION DUE TO CLAMPS SHOULD BE REMOVED COMPLETELY BY CONTROL CUTTING.
03. SHIFT OF AXIS OF DIE IS UPTO 2.0 MM.
04. PROJECTIONS DUE TO CUTTING OF BURR IS UPTO 2.5 MM.
05. ECCENTRICITY OF BROACHING HOLE IS UPTO 3.0 MM.
06. UN-SPECIFIED FILLET RADII R 10
07. DIMENSIONS WITHOUT TOLERANCES NEED NOT BE CHECKED.
08. MARK THE PART NO. "328" AND CODE OF CHIEF
09. PAINT RED OXIDE.

FIRST OPERATION(FORGING)

(SHEET 1 OFF 2)

FORGING IS COMMON FOR
COMPT. NO. 172.40.330/F

T 90

| MATERIAL | FORGING WT. | | |
|-------------------------------------------------|----------------------------|-----------------------------------------|--|
| 20X2H4A GOST 4543-71 | 68.0 KGS | | |
| ALT. MATERIAL | HAMMER | SCALE | |
| | | NTS | |
| DRAWN | CHECKED | APPROVED | |
| <i>L. Ruff</i> 18/8/03 | <i>M. R. R.</i> 18/8/03 | <i>S. J. R.</i> | |
| DRAWING NO. 172.40.328/F | | NOMENCLATURE: R-H EXTREME ENGAGING RING | |
| HEAVY VEHICLES FACTORY AVADI, CHENNAI | | | |

DRAWING NO.
172.40.328/F

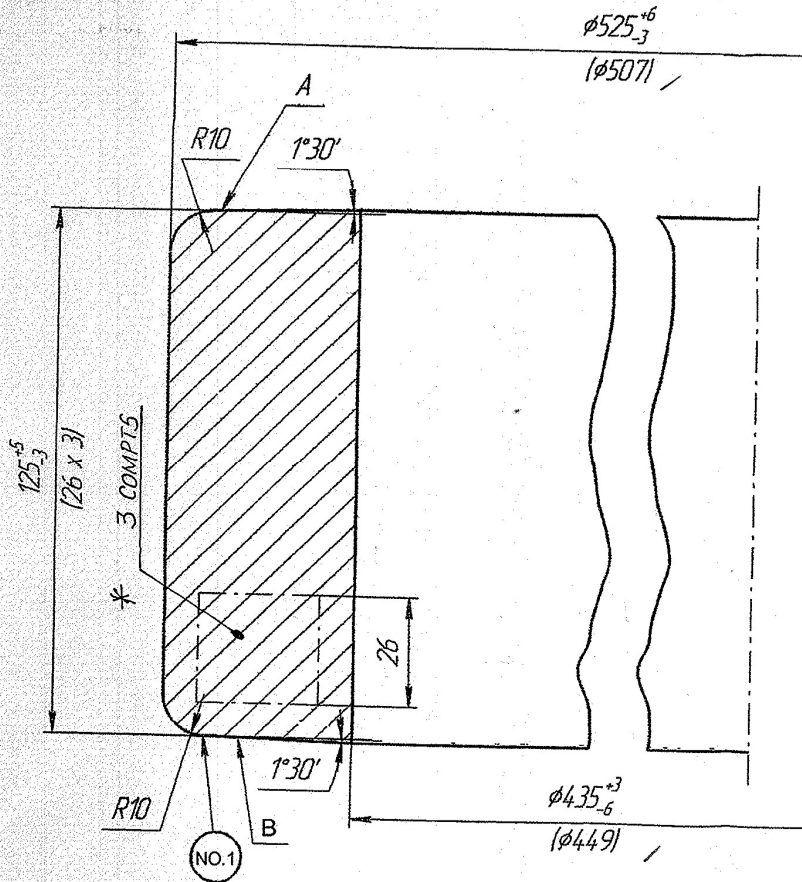

TECHNICAL REQUIREMENTS.

01. MARK THE PART NO. "328" AND CODE OF CHIEF.
02. ≤ 256 HB
03. DESCALES (SHOT BLASTING)
04. ON SURFACE OF FORGING, OCCASSIONAL DEFECTS WITHOUT THEIR REMOVAL IS ALLOWED, IF THEIR DEPTH IS DETERMINED BY CONTROL CUTTING AND DOESN'T EXCEED 0.5 OF ACTUAL SINGLE SIDED MACHINING ALLOWANCE.
05. ON SURFACES 'A' AND 'B', DRAFTS 3 IS ALLOWED.
06. ALONG THE PARTING LINE OF GAUGES BURRS ARE ALLOWED.
07. DEVIATION FROM CIRCLE AND CYLINDRICITY SHOULD BE WITHIN TOLERANCE LIMITS.
08. IN-COMPLETENESS IN JOINT OF GAUGE SHOULD NOT EXCEED R 15.00 MM
09. PAINT RED OXIDE.

SECOND OPERATION (ROLLING)

(SHEET 2 OFF 2)

FORGING IS COMMON FOR COMPT. NO.
172.40.330/F

T 90

| MATERIAL | FORGING WT. | |
|-----------------------------------------|-----------------|-----------------|
| 20X2H4A GOST 4543-71 | 68.0 KGS | |
| ALT. MATERIAL | HAMMER | SCALE |
| | | NTS |
| DRAWN | CHECKED | APPROVED |
| <i>L. Ruff</i> 12/18/03 | <i>M. J. P.</i> | <i>S. J. S.</i> |
| DRAWING NO. | 172.40.328/F | |
| NOMENCLATURE: RH EXTREME ENGAGING RING. | | |
| FORGING | | |
| HEAVY VEHICLES FACTORY | | |
| AVADI, CHENNAI | | |

NOTE:-

01. THE FORGING TECH. REQUIREMENTS CALL FOR DIE FORGING OPERATION AS WELL AS ROLLING OPERATION. INSPECTION IS REQUIRED AT EVERY STAGE.

02. EACH FORGING Caters FOR THREE COMPTS.