

THIS DOCUMENT AND THE INFORMATION CONTAINED IN IT ARE PROPRIETARY AND CONFIDENTIAL TO OFT. NO PERSON OR ENTITY IS ALLOWED TO COPY, REPRINT, REPRODUCE OR PUBLISH ANY PART OF THIS DOCUMENT, NOR DISCLOSE ITS CONTENTS TO OTHERS, NOR MAKE ANY USE OF IT, NOR ALLOW OR ASSIST OTHERS TO MAKE ANY USE OF IT UNLESS BY THE PRIOR WRITTEN EXPRESS AUTHORIZATION OF OFT AND THEN ONLY TO THE EXTENT AUTHORIZED.

SHEET REV STATUS
ALL SHEETS ARE THE SAME REVISION

REVISION RECORD				
REV	ECO	DESCRIPTION	DATE	APVD
01		Freeze	08-Jul-19	I. Arbitman
-		Identical To Previous	13-Aug-19	M. Dafner
A-	LG0029/00	Released	04-Nov-19	L. Goldshtein

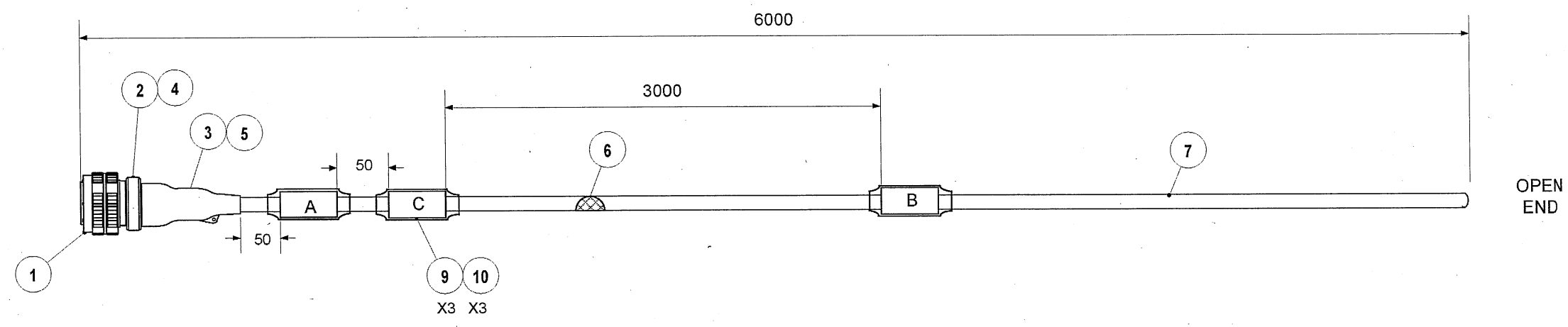

NOTES:
1. MANUFACTURING ACCORDING TO ELBIT 03711A-00

STAMPING REQUIREMENTS:

A	B	C
WNH3A_P1 TO DSS	ELBIT DSS_WNH3A Y30372A-XX S/N__MM/YY REV:___	PART OF CABLE WNH3A Y20103

SEE SEPARATE PARTS LIST

UNLESS OTHERWISE SPECIFIED		SIGNATURE	DATE	ORDNANCE FACTORY TIRUCHIRAPPALLI	
DIMENSIONS ARE IN MM PER ASME Y14.5M -1994		DRAWN	<i>[Signature]</i>	<i>[Date]</i>	
TOLERANCES LINEAR ANGULAR		CHECKED			
3rd. ANGLE PROJECTION		HOS/DDO	<i>[Signature]</i>		
SURFACE TEXTURE IN Micro INCH		OFFICER/PRODN			
		OFFICER/OC			
		OFFICER/DDO			
TITLE			CABLE ASSY, DSS_WNH3A OF: 12.7mm SRCG		
SIZE	CAGE CODE	DWG NO			
C	2291A	Y30372A-00	A-		
SCALE 1:1			SHEET 1 OF 2		

[Signature]
PROJECT OFFICER

DWG NO
Y30372A-00
SH
1

THIS DOCUMENT AND THE INFORMATION CONTAINED IN IT ARE PROPRIETARY AND CONFIDENTIAL TO OFT. NO PERSON OR ENTITY IS ALLOWED TO COPY, REPRINT, REPRODUCE OR PUBLISH ANY PART OF THIS DOCUMENT, NOR DISCLOSE ITS CONTENTS TO OTHERS, NOR MAKE ANY USE OF IT, NOR ALLOW OR ASSIST OTHERS TO MAKE ANY USE OF IT UNLESS BY THE PRIOR WRITTEN EXPRESS AUTHORIZATION OF OFT AND THEN ONLY TO THE EXTENT AUTHORIZED.

DSS_WNH3A

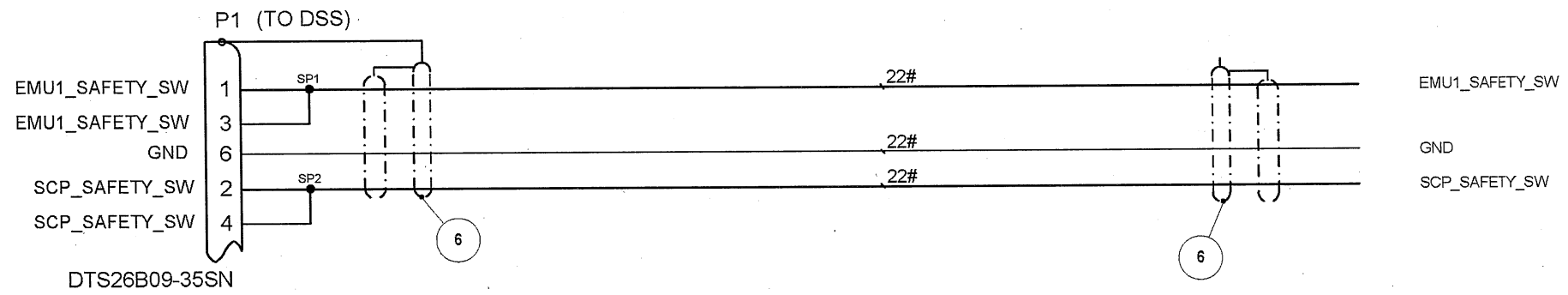

SIZE C	CAGE CODE 2291A	DWG NO Y30372A-00	REV A-
SCALE 1:1		SHEET 2 OF 2	

DWG NO
 Y30372A-00
 SH
 2

OFT

ASSEMBLY PARTS LIST

Assembly Parts List For: Y30372A-00

Rev: A-

Status: Released

Description: CABLE ASSY, DSS_WNH3A

FN	CMD	PART NUM	ECO	DESCRIPTION	MB	QTY	U/M	REF. DES./REMARKS	MFG. PN / CUSTOMER	LA	LI
1	PO	00150473N		PLUG CIRC 6 S NO.09 MARIN.BRON	P	1.000	EA	P1	44163-DTS26B09-35SN		
2	PO	00150368N		BACKSHELL CONN #09 38999-3,4 S	P	1	Each	BS P1	56194-BTH1-09-04-2-Z		
3	VW	20008549L		BOOT SHRINK STR .92 TO .41	P	1	Each		58034-202K121-100		
4	PO	00015525N		BAND CLAMP ID.8 W.120 F/BCKSHL	P	1	Each	BAND P1	47017-600-057-1		
5	YR	00003356N		ADHESIVE EPOXY POLYAMID KIT FO	P	30.000	GM		20012-S1125 KIT-8		
6	VW	20009486L	LG0029	BRAID TUBE .078ID CU/TIN(.125X	P	6.000	MR		59319-A-A-59569R36T0078		
7	VW	20516811900 (34356506M)		TUBE SHRINK .187/.093 BLK F.R.	P	6.000	MR		55386-DR-25-3/16-0-SP		
8	YR	22016520877 (99620607M)		TAPE ELECT. TEFLON 0.5IN WIDE	P	39.370	IN		53011-60-0.5IN WIDTH		
9	VW	40687010377 (99963630M)		MARKER SLEEVE 1/4DIAx2.0 WHT	P	3	Each		58011-TMS-SCE-1/4-2.0-9		
10	VW	40687012377 (99941579M)		TUBE SHRINK .250/.125 CLR F.R.	P	0.210	MR		20012-M23053/18-206-C		
11	VW	99931061M		SPLICE CRIMP BUTT 26-20AWG 1TO1	P	2	Each		60830-D-436-36		
12	WO	99934665M	LG0029	CABLE ELECT 3X 22 AWG WHT ETFE	P	6.000	MR		60016-M27500-22SB3 T23		