

FOLLOWING TO BE STENCIL IN ENGLISH
WITH LETTER HEIGHT 20 TO 25mm

TO,
G.M. O. F. KHAMARIA
TO,
Sr. G.M. O. F. AMBAJHARI, NAGPUR
84mm CG, LOT No.: _____, QTY: _____
TPT / HEAT, H.E. / ILLU

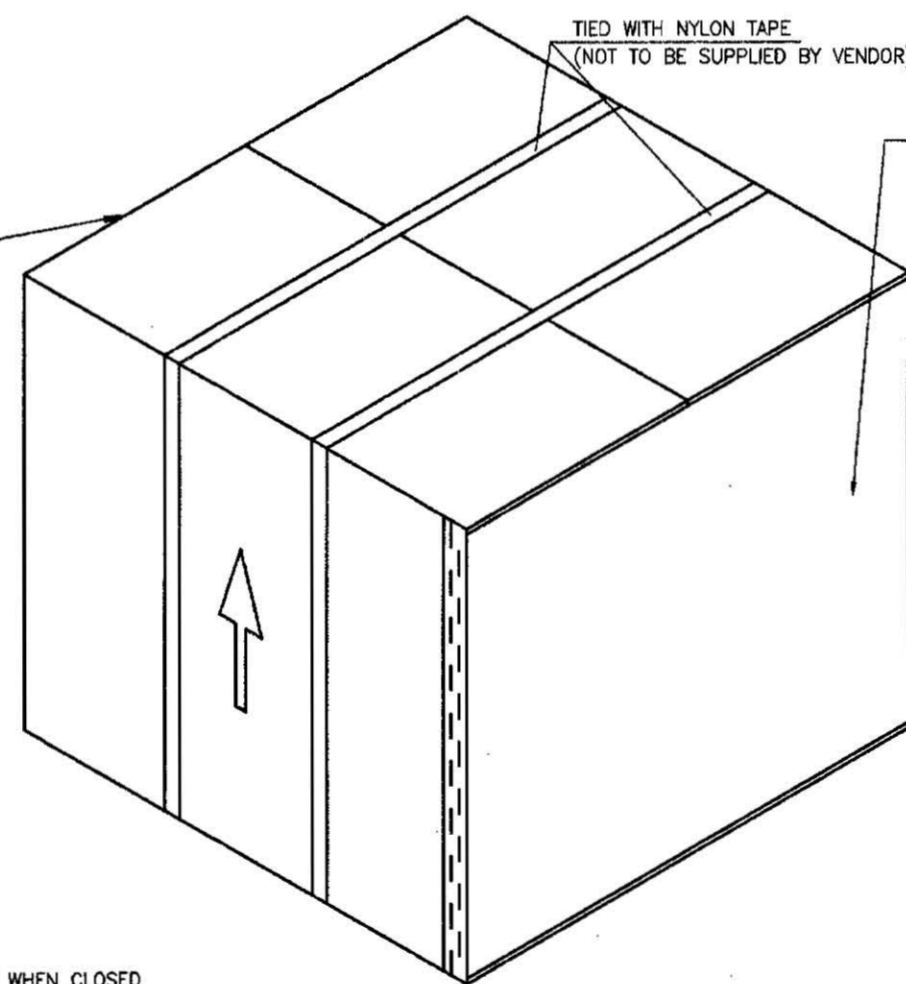

BOX IN CLOSED CONDITION

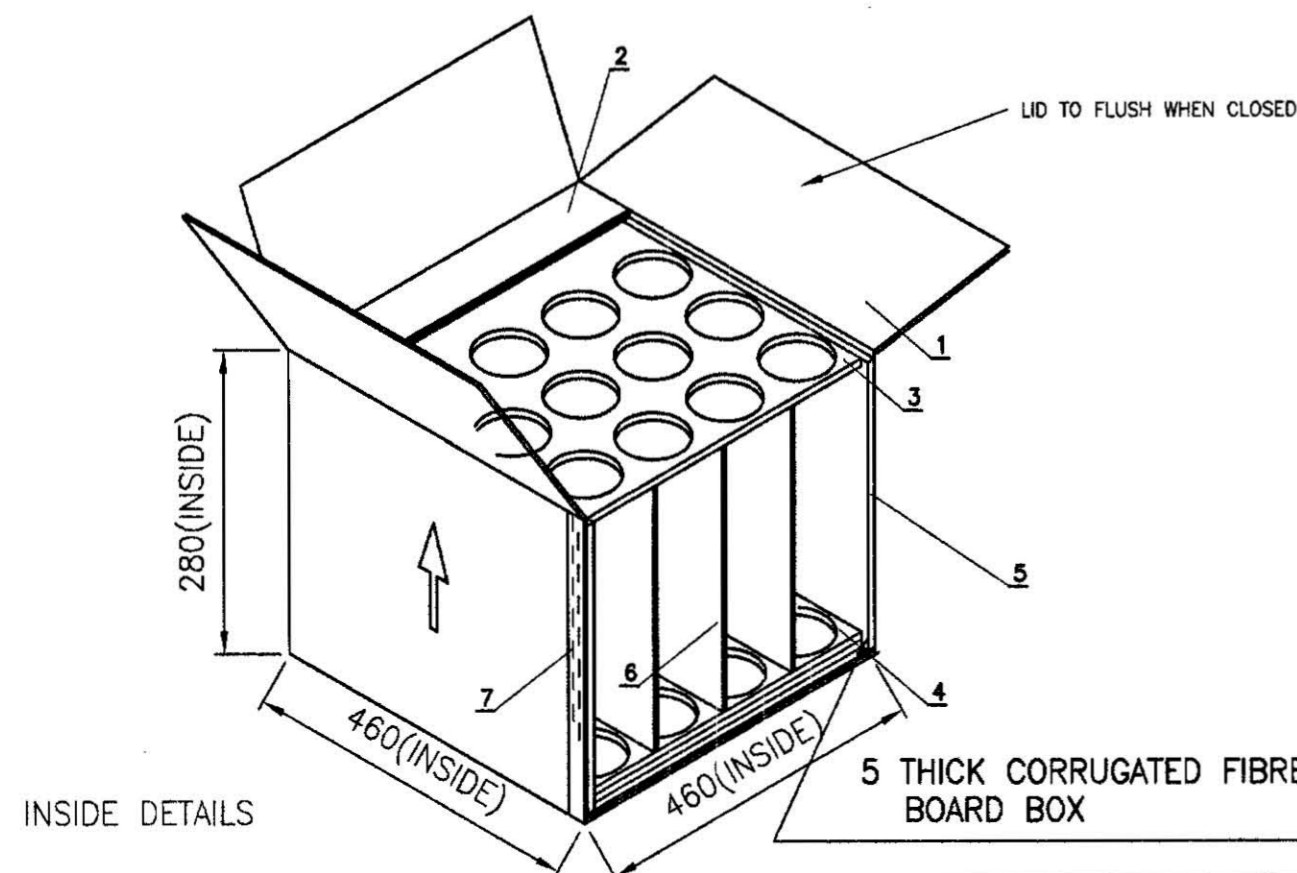

FOLLOWING TO BE STENCIL IN HINDI
WITH LETTER HEIGHT 20 TO 25mm

सेवा में,
महाप्रबंधक ऑ. फ़ै. खमरिया
द्वारा- महाबंधक ऑ. फ़ै. अंबाझरी, नागपुर
84 mm सी.जी, लॉट सं- संख्या
टी.पी.टी/हीट, रच ई. / आय रज रज.

NOTE: ALL PARAMETERS ARE GOVERNED BY THE SPECN IS:2771 Pt.1 LATEST ISSUE & SUBJECTED TO PROPER FITMENT OF ALL THE PARTS

- MATERIAL FOR PART NO-1 & 6:**
150 GSM KRAFT PAPER 5PLY, DOUBLE WALL CONSTRUCTION, NARROW FLUTTING, 5mm THICK,
- MATERIAL FOR PART NO-2:**
120 GSM KRAFT PAPER 13 PLY, 6 WALLS, NARROW FLUTTED, 15mm THICKNESS & CROSS FLUTTED i.e ALTERNATE FLUTES SHOULD RUN ACROSS EACH OTHER
- MATERIAL FOR PART NO-3 & 4:**
120 GSM KRAFT PAPER 8PLY, 4 WALLS NARROW FLUTTING 15mm THICKNESS AND CROSS FLUTTED i.e ALTERNATE FLUTES SHOULD RUN ACROSS EACH OTHER.
- MATERIAL FOR PART NO-5:**
120 GSM KRAFT PAPER 13 PLY, 6 WALLS, NARROW, VERTICAL FLUTTING 15mm THICKNESS.
- THE COMPLETE BOX WHEN TESTED FOR SUBSTANCE, SHOULD WEIGH MINIMUM 2.8 KGS.
- THE BOX AND ALL THE PARTS SHOULD BE MARKED WITH MANUFACTURES NAME/INITIAL/TRADE MARK.
- GENERAL WORKMAN-SHIP AND FINISH SHALL BE GOOD THROUGH OUT

PART	DESCRIPTION	NO. OFF	MATERIAL	REMARKS
7	STAPLING			
6	PARTITION	6		
5	SIDE SHOCK ABSORBER	4		
4	MOUTH SUPPORT	1		
3	UNDER HEAD SUPPORT	1		
2	SHOCK ABSORBER (TOP & BOTTOM)	3		
1	PACKING MATERIAL	1		

PART LIST			ORDNANCE FACTORY AMBAJHARI	
DIMENSIONS ARE IN mm			AS ABOVE	
THIRD ANGLE PROJECTION			NOMENCLATURE:	
SCALE : NTS			CORRUGATED FIBRE BOARD PACKING CARTON FOR SIXTEEN CASES	
2015	NAME	DATE	DRG. NO: CC-235 K	
DRAWN		10.06.15	SHEET NO: 1	
CHECKED			NO. OF SHEETS: 1	
HOS/CDD		10/06	OPERATION NO:	
JWM/CCS		10/06/15	COMPT: CARTG. CASE	
HOS/CCS			M/C:	
JWM/CCS			STORE: 84mm CG	

REV.	DATE	NOMENCLATURE	SIGN.
104/15	12-06-2015	NOMENCLATURE PACKING CARTON WAS PACKING BOX & NEW NEGATIVE MADE	