

CERTIFIED CORRECT COPY
OF APPROVED DRAWINGS
AT THIS DATE: 01.04.2021
Designer & Drawing Office
Ordnance Factory,
Tiruchirappalli-620016

UN CONTROLLED COPY

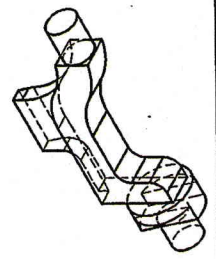
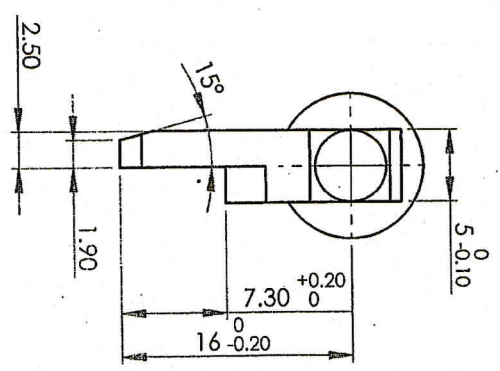
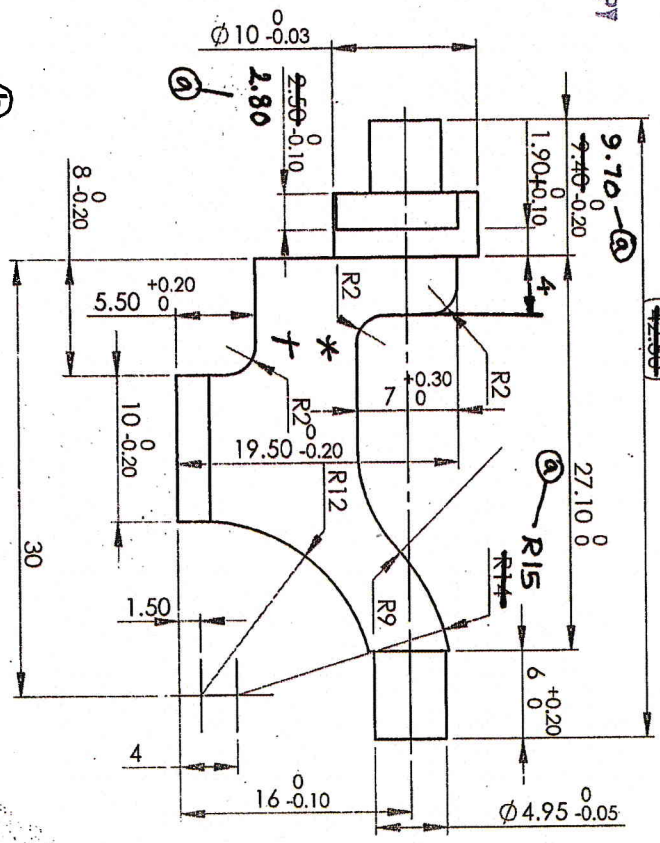
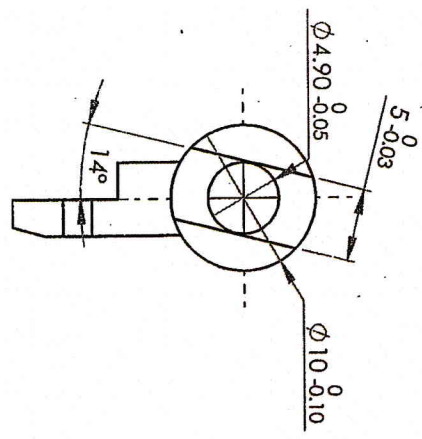

Material:
Steel BS:970 Pt.1 1983 Gr.817 M40 (or) En-24
Steel BS:970 Pt.1 1983 Gr.709 M40 (or) En-19
Steel BS:970 Pt.1 1983 Gr.708 M40 (or) En-19A

Note:
Item to be supplied without Heat treatment.

For Casting route
BS:3146 PART-1, 1974 Class:5, Grade:A
Non Stressed Component
Radiographic test as per ASTM-E-192

Acceptance Standard:-
Gas note & Foreign Material: Level-3
Shrinkage (All Types): Level 3

MARKING: -
* MANUFACTURER CODE
+ BATCH / YEAR OF MANUFACTURE

ENGRAVING DEPTH 0.1MM &
HEIGHT 3MM.

DA.No. 49/20 Dt. 24/11/20	DA.No. 26/20 Dt. 18.3.20	DA.No. 24/20 Dt. 10/3/20	SIG. & DATE	APPROVED ON: 27/04/2018	OFFICER/ PRDND.	DIV./OFFICER/ D&DO	TRACED	SIGNATURE & DATE	SUB: SELECTOR LEVER	SCALE NTS
									FOR: K2070 SELECTOR ASSY	Weight(g) 12.44
									OF: TRICHY ASSAULT RIFLE	SHEETS: 1
									DES. REF. NO: K-2074	SHEET No.: 1
									DRG. No.: TEND-2573 *3	
									ORDNANCE FACTORY TIRUCHIRAPPALLI-16.	