

ALT.MATERIAL : STEEL 40 X GOST 4543-71 ✓

MATERIAL FOR INDIA

- BS 970 PT. 1 : 1983 GR. 530 M-40 (BS 970 : 1955 EN-18)
- OR
- BS 970 PT. 1 : 1983 GR. 709 M-40 (BS 970: 1955 EN-19)
- OR
- BS 970 PT. 1 : 1983 GR. 708 M-40 (BS 970: 1955 EN-19 A)

NOTE
 ACCEPTANCE STANDARDS FOR MACRO ETCH TEST & MICROSCOPIC DETERMINATION OF NON METALLIC INCLUSIONS FOR STEEL
 1. MACRO ETCH TEST AS PER ASTM- 381 WITH ACCEPTANCE STANDARD AS C2, R2, S2
 2. NMR TEST AS PER IS : 4163 - 82 ✓
STRESSED COMPONENT

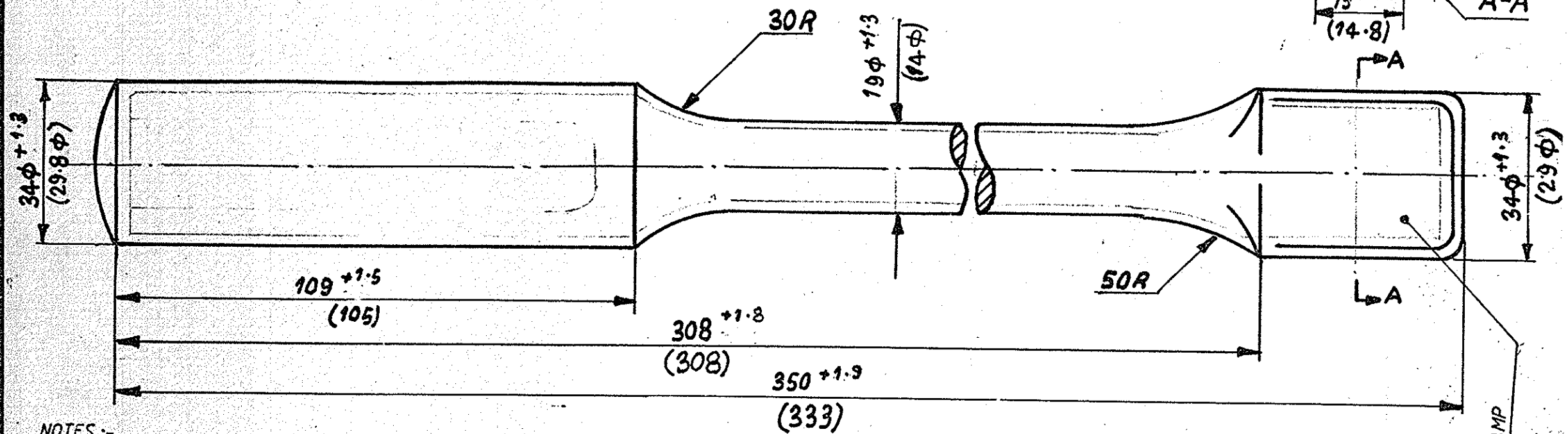
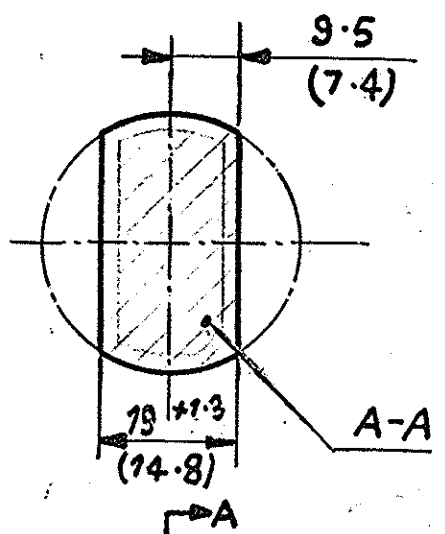

- NOTES:-**
1. DIMENSIONS ARE IN mm.
 2. FIRST ANGLE PROJECTION.
 3. SCALE:- 1:1
 4. FORGING OF GROUP III AS PER GOST 8479-70, HB 217 MAX.
 5. DRAFT ANGLE 7°.
 6. UN-SPECIFIED RADII 2R.
 7. FLASH REMAINDER UP TO 0.9 mm.
 8. WARPING UP TO 1.2 mm.
 9. DIE SHIFTING UP TO 0.6 mm.
 10. CONVENTIONAL CONTOUR AND DIMENSIONS GIVEN IN BRACKETS PERTAIN TO THE FINISHED PART.
 11. STAMP PART NO, MELT NO. AND Q.C.D STAMP
 12. 100% OF A BATCH SHOULD BE CHECKED FOR HARDNESS AS PER GOST 8479-70.
 13. WEIGHT OF THE FORGING 1.540 Kgs.
 14. DISPLACEMENT OF 19φ AND DIMENSION 19 WITH RESPECT TO 34φ IS UP TO 0.8mm.

HEAT-TREATMENT:-FORGINGS ARE NORMALIZED AND TEMPERED.
 FOR HEAT-TREATMENT SCHEDULE REFER DRAWING NO: M 881 SHEET NO: 1 TO 3 AND SHEET NO: 5 SL.NO: 10.
 MATERIAL:- STEEL 40X . OST 3-98-80 ✓

VETTED FOR MATERIAL ONLY

[Signature]
 Principal Scientific Officer,
 Quality Assurance Officer,
 For Senior Quality Assurance Officer,
 Senior Quality Assurance Esst. (Arms)
 Tiruchirappalli - 620 016.

COMPONENT DRG. NO. 6P11-3-4
PISTON

DRAWING PROVISIONAL D.S. CAT NO. 1005007295

1	2	3	4	5	6	7	8
<i>Sadhi</i> 20/10/87	<i>[Signature]</i>	11.87	<i>[Signature]</i> 7-11-87	<i>[Signature]</i>	ORDNANCE FACTORY, TIRUCHIRAPALLI-16.	DRG.NO: 62 C 3004 200 B 3	
REDRAWN	CHECKED	APPROVED	1/C, D & D.O.	DIV.OFFICER			

B	ALTERNATE MATL.'EN'SERIES ADDED	<i>[Signature]</i> 9.11.87
AMENDMENTS	DESCRIPTION/DETAILS	SIG & DATE