

REFERENCE DRAWING NO. ARDE-1135, DETAIL NO.14

DRG.NO. **FS-514'G'**

GENERAL TOL  $\pm 0.2$

COMPRESSIVE BREAKING LOAD IN VERTICAL POSITION 160Kg.  
ESTIMATED WEIGHT 12g.

**AMENDMENTS**

| REV    | DATE     | DESCRIPTION  | SIGN |
|--------|----------|--|------|
| 238/08 | 24/07/08 | NEW DRAWING MADE AS PER LATEST DRAWING ISSUED BY ARDE AMENDED VIDE L.NO. AL.NO. 08/2008 DT.13/02/08 R.GM/RAD |      |
| 140/12 | 16/10/12 | * ALT. Mat. added. Asper. L.no. Rcmr/1443/1/Techno. Shikha   |      |

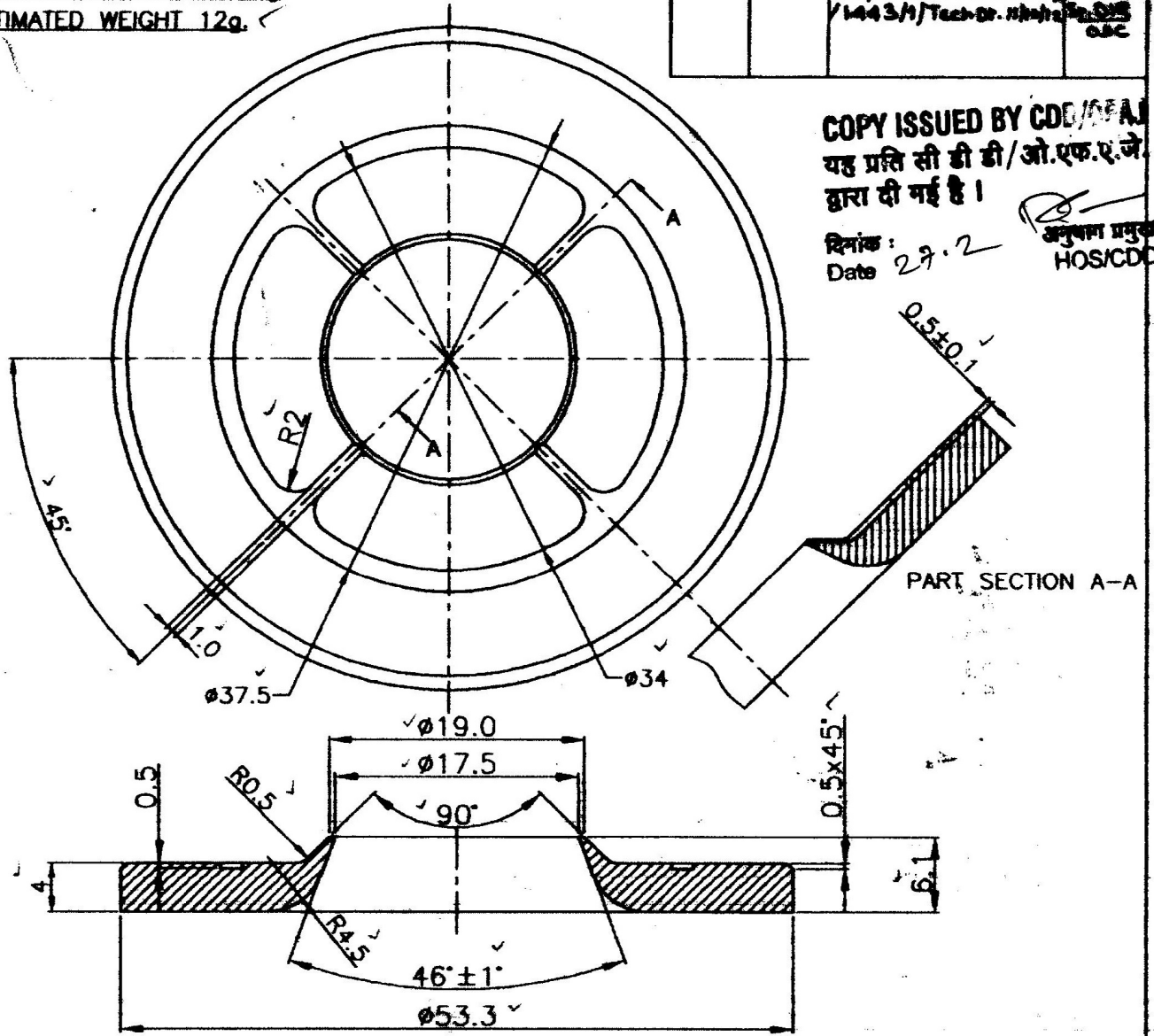

**COPY ISSUED BY CDD/ARDE**  
यह प्रति सी डी डी/ओ.एफ.ए.जे. द्वारा दी गई है।  
दिनांक : 27.2  
Date  
अनुमान प्रमुख  
HOS/CDD

\* ALT. MATERIAL : PHENOL FORMALDEHYDE RESIN & CHOPPED STRAND LEACHED GLASS : SP-16 TO SPECN IA:1330 APPENDIX 'D'.

- NOTE:-
- MOULDING POWDER & MOULDED WASHER SHOULD CONFORM TO JSS 9330-05-2002
  - WITH 40% ASBESTOS TO SPECN. IND/ME/25 IN NATURAL COLOUR, IMPACT STRENGTH
  - 0.011Kgf/m(0.08 Lbf/ft) .TENSILE STRENGTH 281.2 Kg/cm<sup>2</sup>(4.000 PSI).

|                        |          |          |  |  |  |
|------------------------|----------|----------|--|--|--|
| DIMENSIONS ARE IN mm.  |          |          | <b>MATERIAL:</b>   |  | <b>आर्डनेन्स फैक्टरी अम्बाझरी</b><br><b>ORDNANCE FACTORY AMBAJHARI</b> |
| THIRD ANGLE PROJECTION |          |          | MOULDING POWDER-MOULDED PLASTIC (PHENOLIC) TO JSS 9330-05-2002 WITH 40% ASBESTOS FILLER. |  |  |
| SCALE: N.T.S           |          |          | NOMENCLATURE   |  | DRG. NO.   |
| 2008                   | NAME     | DATE     | <b>SEALING WASHER</b>  |  | <b>FS-514'G'</b>   |
| DRAWN                  | अनुमान   | 24/07/08 |  |  |  |
| CHECKED                |          | 24/07/08 |  |  |  |
| JWM/CDD                |          | 24/07    |  |  |  |
| APPVD                  | JLGM/RAD | 24/7     |  |  |  |
|                        |          |          | STORE: 68mm ARROW ROCKET   |  | SHEET NO.- 1   |
|                        |          |          |  |  | NO OF SHEETS- 1  |
|                        |          |          |  |  | OPERATION -  |
|                        |          |          |  |  | COMPT.   |

Ref: FS-514'E'