

SECTION A-A
HOS/MPM

FINISH:- PHOSPHATED TO SPECN. JSS-0465-01-1988
CLASS II (ACCELERATED) OIL FINISH

ASSY. DRG. NO. AR-11-RF1

ALL DIMNS. ARE IN mm.

DATE: 9-2-13
DGN: J. CHAK.
DRN: U. CHAK.
CHKD: RAJESH KUMAR
APPD: [Signature]
RIFLE FACTORY
ISHAPORE

INDIAN ORDNANCE FACTORIES RIFLE FACTORY ISHAPORE		SCALE:- 1:1	2016	NAME	DATE
7.62 mm. ASSAULT RIFLE (GHAATAK) TUBE CYLINDER GAS ASSY. (WEI'NING)		1:1	DGN.	J. CHAK.	27-07
		APPD.	DRN.	U. CHAK.	
			CHKD.	RAJESH KUMAR	AMM/COO
			APPD.	[Signature]	

DRG. NO.:-
AR-10-RF1

SHEET 1 OF 1

DC RFI NO. DT

11C/041/16, 17/11/16

9/11/16

11C/041/16, 17/11/16

DC RFI NO. 11C/019/17 DT 28-08-2014

$\phi 19,30 -0.05$

$30^{\circ}0'0''$

$\phi 16,5 +0.1$

65-0

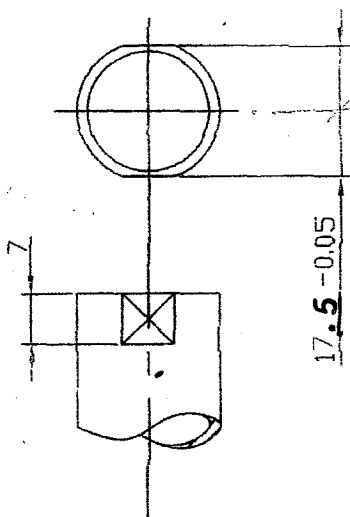

$17.5 -0.05$

7

$\phi 14.4 +0.05$

$\phi 14,2 +0.05$
BEFORE DRAW
BORING

173.8-0.2

$1 \times 30^{\circ}$

$\phi 17,0 -0.05$

मानक प्रति / CERTIFIED COPY OF
 डाइंग / लेआउट / गेज शिड्यूल H₀₂/MPM
 DRG/LAYOUT/GAUGE SCHEDULE
 दिनांक / AT THIS DATE.. 28.08.17
 सी डी डी / CDD
 राइफल फॅक्टरी, ईशापुर
 RIFLE FACTORY, ISHAPUR

ALL DIMNS. ARE IN mm.
 IMPT. DIMNS. ARE MKD. THUS \oplus
 INFN. MKD. THUS \dagger TO BE MKD. ON

MATL:- BS.970 PT.I 1983 708M 40(T)
 HARDNESS :- 250- 300 HV

INDIAN ORDNANCE FACTORIES
 RIFLE FACTORY
 ISHAPUR

2016	NAME	DATE
DGN.		
DRN.		
CKD.		
APPD.		

7.62 mm ASSULT RIFLE (GHAATAK)
TUBE CYLINDER GAS

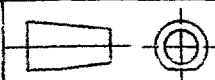

SCALE:- 1:1

DRG.NO.

AR/10/1 ALT/RFI

SHEET- 1 OF- 1

N7L

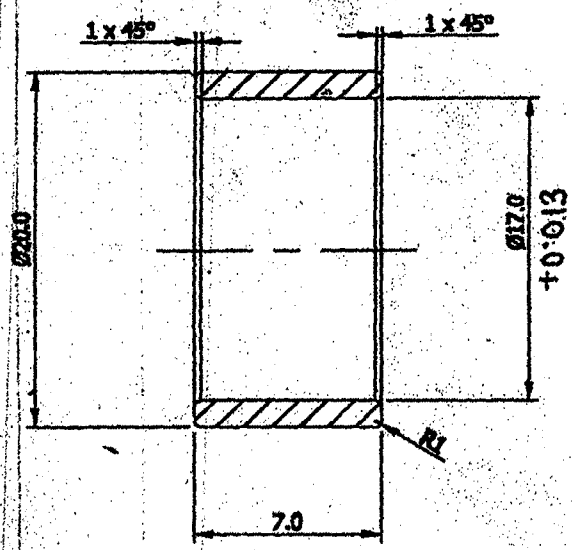

H05/MPM

9-2-17

GIM/RFI

आरेखण की सही प्रमाणित
प्रतिलिपि दिनांक. 13.10.13....
Certified as correct copy
of drg. on.....
2/3/13
K. Jaisankar
Jr. Works Manager
STANDARD CITY

MATL:- BS.970 Pt. II 1970 M-40 (T)
HARDNESS:- 250-300 HV

DIMN.ARE IN mm

RIFLE 7.62 mm L.P.
COLLER CYLINDER GAS

DRN.	A. K. BOSE
CKD	Samyad
APPROVED	
29/8 J.W.M. D.O.	
DRAWING NO	
AR/10 /6 ALT.	
SHT 1 OF 1	

SCALE
6 : 1

SMALL ARMS FACTORY
KANPUR

DA NO	DATE	AMENDMENTS	SIGN.	MTL
10/2002	15-02-2002	DIM 10.0 WAS 11.0	<i>[Signature]</i>	

CERTIFIED COPY OF
 LAYOUT/CAUGE SCHEDULE
 AT THIS DATE... 9-2-17
 SMALL ARMS FACTORY, KANPUR

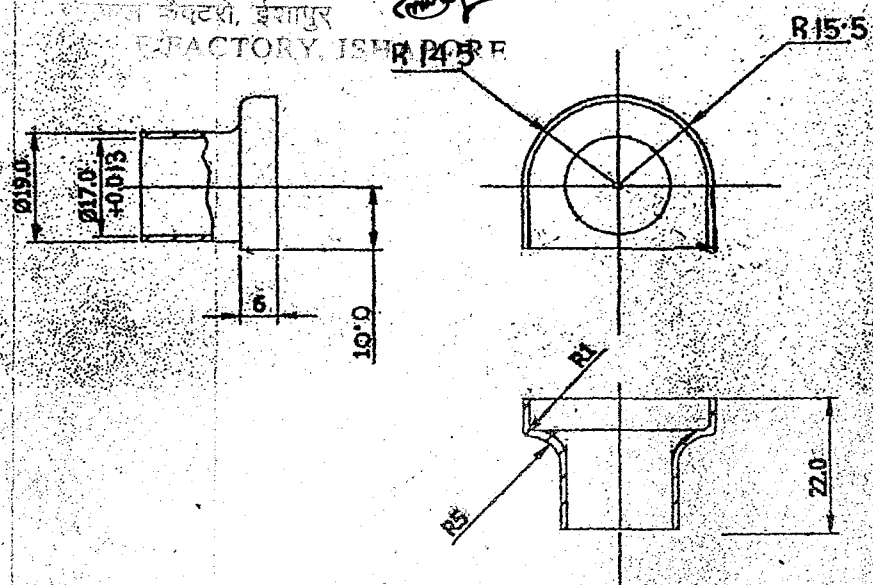

PROTECTIVE FINISH:-
 PHOSPHATED TO SPECN WPN/GEN/3 CLASS II 13 (J)

MATL:- IS:7226 - C 40
 HARDNESS:- 250-300 HV

DIMN. ARE IN mm

G.M./R.F.F.
 आरेक्षण की सही प्रमाणित
 प्रतिलिपि दिनांक 13/11/13.....
 Certified as correct copy
 of drg. on.....
 21/13/13
 SCALE
 1:1
 STANDARD C.M.I.
 Sr. Works Manager

RIFLE 7.62 mm L.P.

CUP CYLINDER GAS

SMALL ARMS FACTORY
 KANPUR

DRN.	A. K. BOSE
CKD	Sanyal
APPROVED <i>[Signature]</i> 21/13 J.W.M. D.O.	
DRAWING NO	
AR / 10 / 5 ALT.	
SHT 1 OF 1	

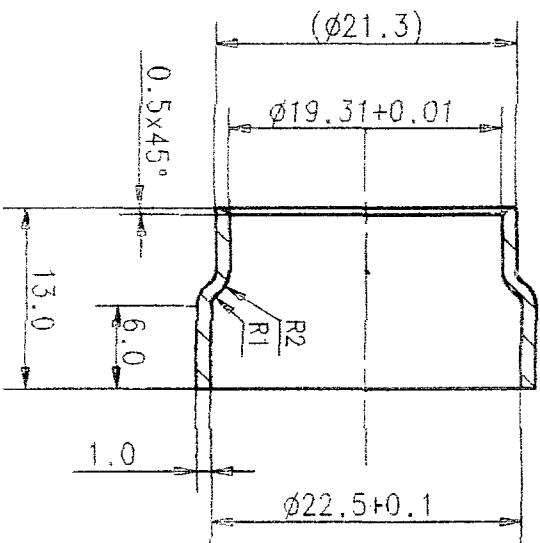
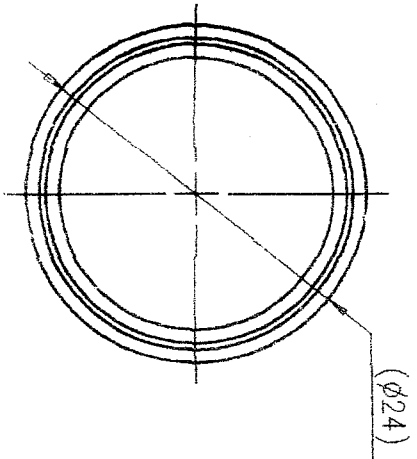

MATERIAL: STEEL B.S 1449:PT 1 1983 CS40 (ANNEALED CONDITION)
 HARDNESS: 250-300 H.V.
 FINISH : PHOSPHATED TO SPECN. JSS:0465/01 1988 CLASS II OIL FINISH.

ASSY. DRAWING NO. AR-11-RF1

INDIAN ORDNANCE FACTORIES
 RIFLE FACTORY
 ISHAPORE

7.62 ASSAULT RIFLE(GHAATAK)
 CUP CYLINDER GAS FRCT

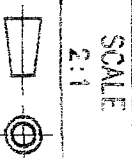

2015	NAME	DATE
DESIGNED		
DRAWN		
CHECKED		
APPROVED		

DRAWING NUMBER
 AR/10/4-RF1

SHEET - OF -

DATE: 9-2-15
 HOS/MPM

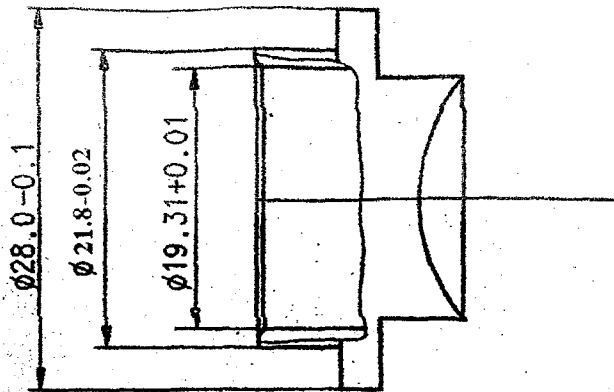

COPY OF
Hq/MPM
SCHEDULE
9-2-17
POME

DC RFI No. DT	
11C/032/16	29/7/16
11C/040/16	16/11/16
11C/001/17	04/10/17

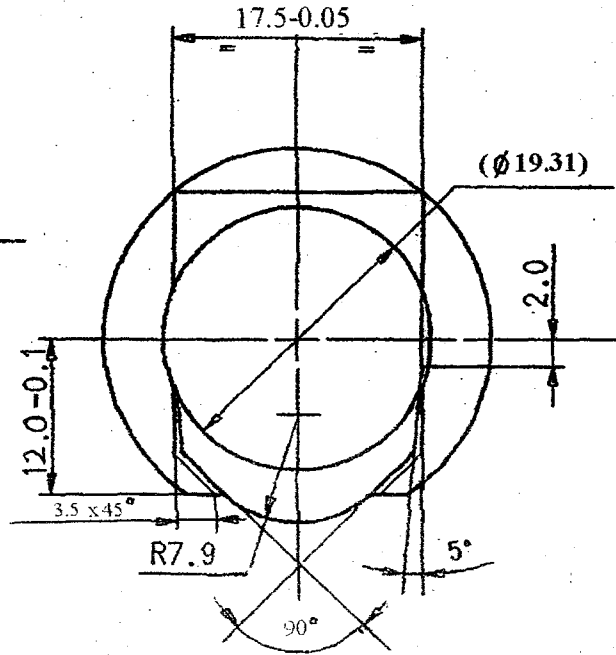
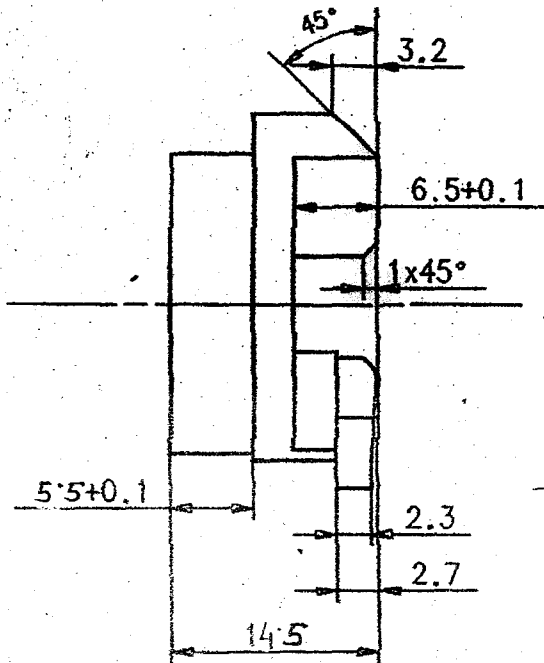

MATERIAL: B.S.970 PT 1 1987 708 M40 (EN 19A -T)
 FINISH:- PHOSPHATED TO SPECN. JSS:0465/01 1988 CLASS II OIL FINISH.
 PROTECTIVE FINISH:- BLACK P.T.F.E. COAT, MATT.FINISH

ASSY.DRAWING NO. AR-11-RF1

INDIAN ORDNANCE FACTORIES
 RIFLE FACTORY
 ISHAPORE

2015.	NAME	DATE
DESIGNED	<i>[Signature]</i>	
DRAWN	<i>[Signature]</i>	
CHECKED	<i>[Signature]</i>	
APPROVED	<i>[Signature]</i>	

7.62 ASSAULT RIFLE (GHAATAK)
 BUSH CYLINDER GAS

SCALE
 2:1

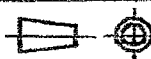

DRAWING NUMBER
 AR/10/3-RF1

SHEET- CF-

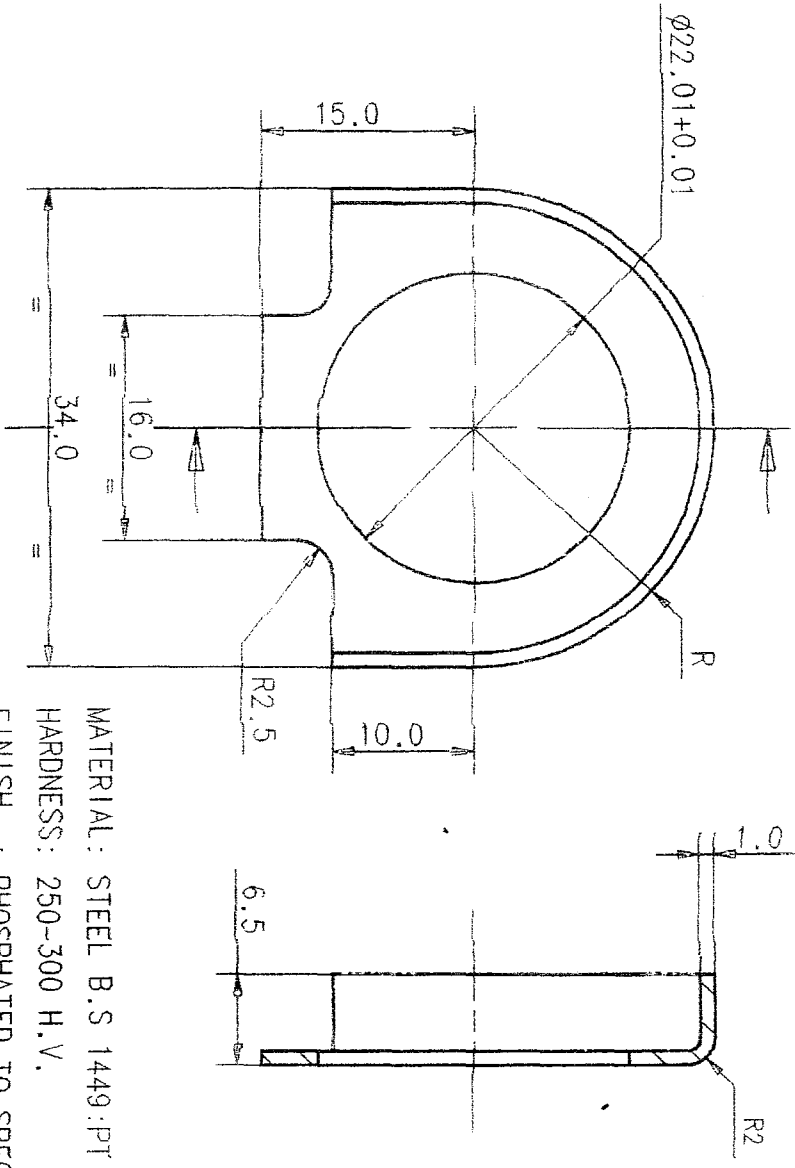

MATERIAL: STEEL B.S 1449:PT 1 1983 CS40 (ANNEALED CONDITION)
 HARDNESS: 250-300 H.V.
 FINISH : PHOSPHATED TO SPECN. JSS:0465/01 1988 CLASS II OIL FINISH.

ASSY. DRAWING NO. AR-11-RF1

INDIAN ORDNANCE FACTORIES
 RIFLE FACTORY
 ISHAPORE

9-2-17
 Hos/MPM

7.62 ASSAULT RIFLE(GHAATAK)
 CUP CYLINDER GAS REAR

SCALE
 2:1



2015	NAME	DATE
DESIGNED		
DRAWN		
CHECKED		
APPROVED		

DRAWING NUMBER
 AR/10/2-RF1

SHEET-
 OF-

Handwritten notes and signatures in the bottom right corner.