

D S CAT No  
5120-415474

DRG CONVENTIONS CONFORM TO IS: 696  
DIMNS ARE IN MM UNLESS OTHERWISE STATED.  
TOLERANCES FOR UNTOLERACED LINEAR DIMENSIONS

ABOVE	-	6	30	120	315	1000	2000	4000
UP TO	6	30	120	315	1000	2000	4000	-
TOLS	±0.1	±0.2	±0.3	±0.5	±0.8	±1.2	±2	±3

TREATMENT:- HRD & TEMP RC 45-50

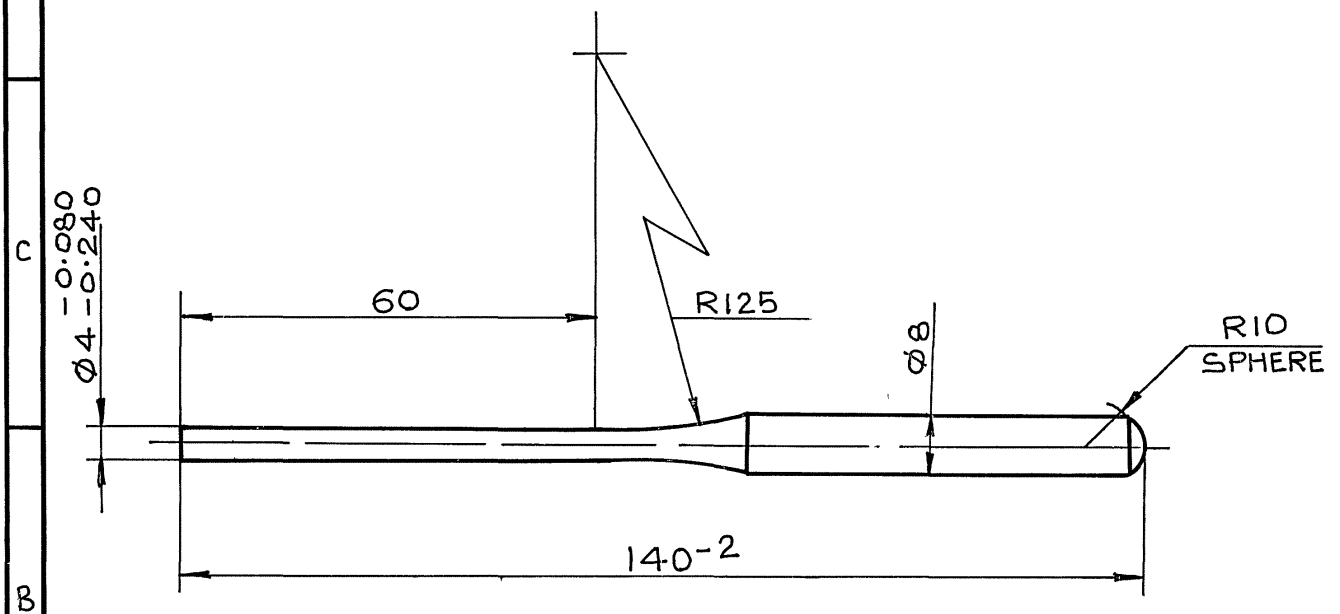

NOTES:-

1. SHARP EDGES SHOULD BE BLUNTED TO R=0.4
2. SUBJECT TO AMENDMENT BASED ON SAMPLE TO BE APPROVED BY AHSP BEFORE COMMENCEMENT OF REGULAR PRODUCTION.

PROTECTIVE FINISH:- PHOSPHATING AS PER SPEC. JSS 0465-10, 1986,  
IMPREGNATION WITH DUNLOP ADHESIVE - 778 OR APC 6  
TO SPEC JSS 8040-12 AND NIGROSINE TO SPEC JSS-1036 ONE LAYER

BASED ON OFT DRG No C 9045

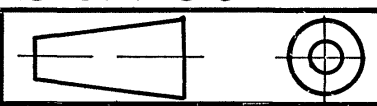
21-1209	19175 W	D S CAT No ADDED & NOMENCLATURE AMENDED		Sig	CQA(W) JABALPUR		
13 <sup>01</sup> / <sub>04</sub>	18845-W	HINDI NOMEN ADDED		M	DRN- JLC	CHD- PNR.	
30-1191		NEW POLY NEG PREPARED		lyp	TCD- Prof. Anand	CHD- <i>[Signature]</i>	
DATE	AUTHORITY	ZONE	NATURE	SIG AHSP	SIG DO		
AMENDMENTS						CHIEF D'MAN	DO
DRG. SEALED:- 16962-W						AHSP	
24.10.90						FOR CQA(W)	
SCALE- NTS		ESTD MASS-		DATE		DESIGN No	
MATERIAL- STEEL 50C8 IS: 5517-1978						CQA/WPN/1286	
ASSY DRG.						PART No	
						ICM 2116	
<u>DRIFT PIN</u> ड्रिफ्ट पिन						DSCAT No. 5120-415474	