

FOR TENDER ONLY

DIMENSIONS ARE IN mm.

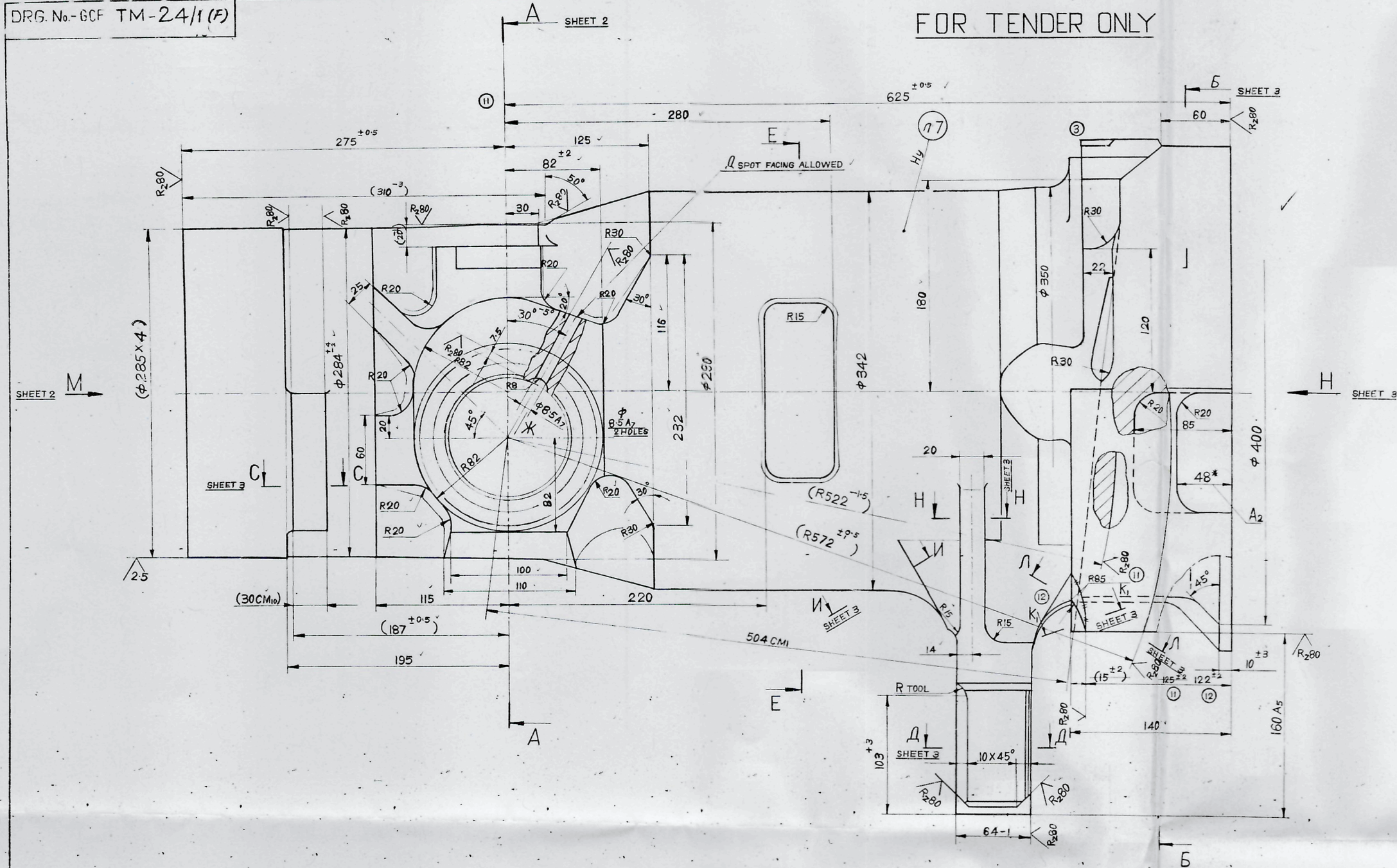

16	1/2	126	14.5
15	2/3	136	14.5
14	1/3	136	13.65
13	1/3	131	13.1
12	1/3	129	12.9
11	1/3	126	12.6
10	1/3	124	12.4
9	1/3	121	12.1
8	1/3	118	11.8
7	1/3	112	11.2

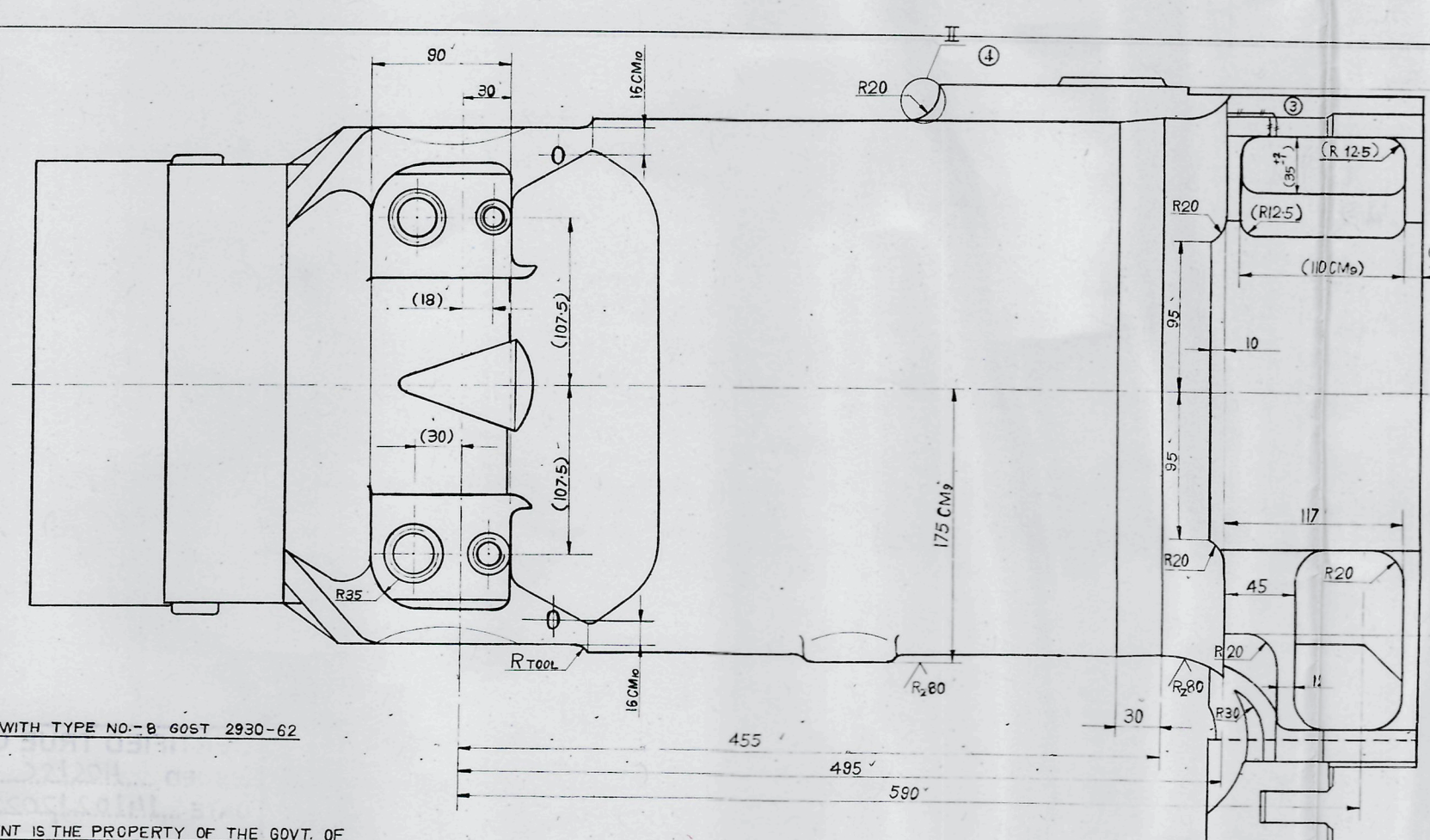
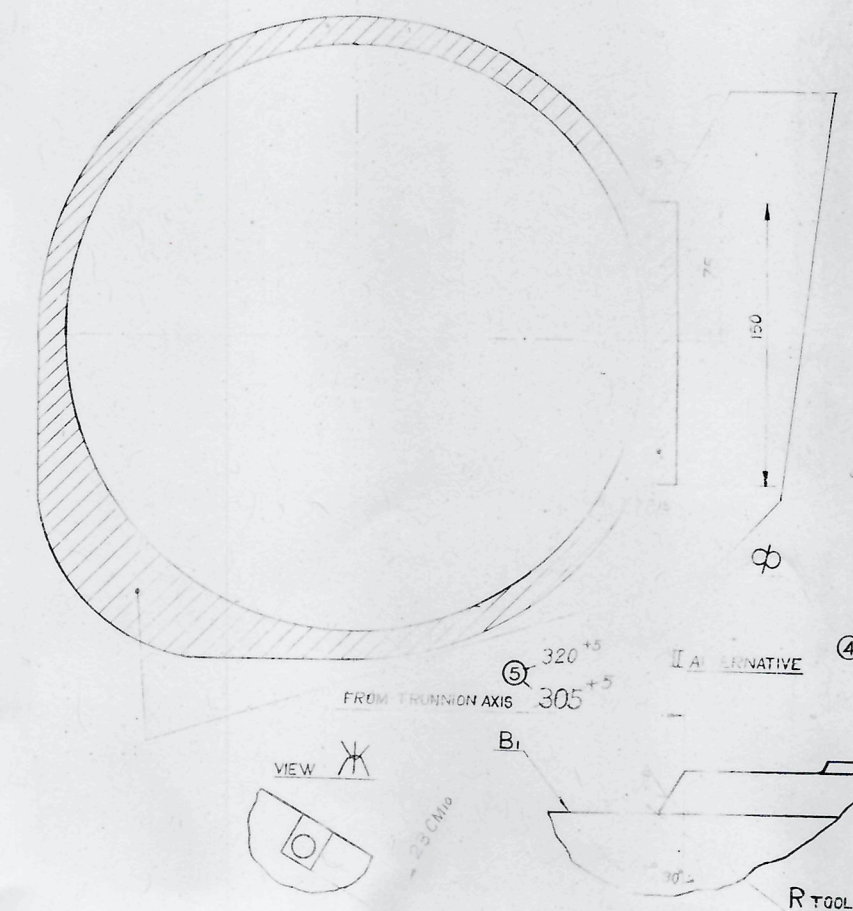

*1
ALL ANGLE < 20° MAXIMUM
FORM TOOL ALLOWED.

5 TO BE MARKED WITH TYPE NO.-B 60ST 2930-62

- NOTE-
- THIS DOCUMENT IS THE PROPERTY OF THE GOVT. OF INDIA M.O.F.D. AND IS ISSUED FOR THE PURPOSE OF DEVELOPING/MANUFACTURING STORES REQUIRED FOR DEFENCE USE.
 - IT MUST NOT BE REPRODUCED/DISCLOSED TO ANY THIRD PARTY OR USED FOR ANY CIVIL PURPOSE.
 - IT MUST BE RETURNED TO THE ISSUING AUTHORITY WHEN THE PURPOSE OF ITS ISSUE HAS BEEN SERVED.
 - PORT SAMPLE TO BE APPROVED BEFORE BULK SUPPLY.

- UNSPECIFIED DIMENSIONS SHALL BE AS FOLLOWS:
OF EXTERNAL DIMENSIONS: R < 6 mm.
OF INTERNAL DIMENSIONS: R < 3 mm.
- CASTING GRINDING SHALL BE AS PER OST B 3-4.
- DIMENSIONS OF MOUNTING BRACKETS SHALL BE OBSERVED AFTER ASSEMBLY.
- ONE CAVITY SHALL BE PROVIDED IN EACH SIDE AND FACE OF THE PART FOR IDENTIFICATION BY WELDING UNIT NOT COMING OUT ON TO SURFACE.
- GROOVE SHALL BE MACHINED IN 2A46.
- INDEX OF ARTICLES DETERMINATION OF COME HEAT NUMBER SHALL BE MARKED.
- TYPE TIG-B SHALL BE USED.
- * DIMENSIONS SHALL BE GIVEN FOR REFERENCE.
- POCKET ALLOWED SHALL NOT BE MADE IN DIMENSIONED SURFACE.
- DIMENSIONS SHALL NOT BE MADE DIMENSIONED SURFACE.

THE CASTING TO BE SUBJECTED TO RADIOGRAPHY AS PER ASTM E-445-84.
CERTIFIED MATERIAL SPECIFICATION ONLY
WRITE LETTER NO. GCF/TM-24/1/0357/TG
DT. 6-3-90

MATERIAL: ALUMINUM
ALTERNATIVE: INDIAN
STEEL: 0 SPECN. IS: 270 E 73
GR-2 HEAT TREATMENT
PER 3G.

SHRINKAGE LEVEL: 0.5%
PER ASTM E-445-84
WITH THICK LINES
SPECN. THE DEFECTS
ARE NOT PERMITTED

GAS POROSITY LEVEL-2
CRITICAL AREAS MARKED
LEVEL-2 OF ABOVE
RS AND INSERTS ETC.

NO.	DATE	BY	REVISION	REMARKS
1	01/01/90	DRG/VETT/UC		
2	01/01/90	DRG/VETT/UC		
3	01/01/90	DRG/VETT/UC		
4	01/01/90	DRG/VETT/UC		
5	01/01/90	DRG/VETT/UC		
6	01/01/90	DRG/VETT/UC		
7	01/01/90	DRG/VETT/UC		
8	01/01/90	DRG/VETT/UC		
9	01/01/90	DRG/VETT/UC		
10	01/01/90	DRG/VETT/UC		
11	01/01/90	DRG/VETT/UC		
12	01/01/90	DRG/VETT/UC		
13	01/01/90	DRG/VETT/UC		
14	01/01/90	DRG/VETT/UC		
15	01/01/90	DRG/VETT/UC		
16	01/01/90	DRG/VETT/UC		
17	01/01/90	DRG/VETT/UC		
18	01/01/90	DRG/VETT/UC		
19	01/01/90	DRG/VETT/UC		
20	01/01/90	DRG/VETT/UC		
21	01/01/90	DRG/VETT/UC		
22	01/01/90	DRG/VETT/UC		
23	01/01/90	DRG/VETT/UC		
24	01/01/90	DRG/VETT/UC		
25	01/01/90	DRG/VETT/UC		
26	01/01/90	DRG/VETT/UC		
27	01/01/90	DRG/VETT/UC		
28	01/01/90	DRG/VETT/UC		
29	01/01/90	DRG/VETT/UC		
30	01/01/90	DRG/VETT/UC		
31	01/01/90	DRG/VETT/UC		
32	01/01/90	DRG/VETT/UC		
33	01/01/90	DRG/VETT/UC		
34	01/01/90	DRG/VETT/UC		
35	01/01/90	DRG/VETT/UC		
36	01/01/90	DRG/VETT/UC		
37	01/01/90	DRG/VETT/UC		
38	01/01/90	DRG/VETT/UC		
39	01/01/90	DRG/VETT/UC		
40	01/01/90	DRG/VETT/UC		
41	01/01/90	DRG/VETT/UC		
42	01/01/90	DRG/VETT/UC		
43	01/01/90	DRG/VETT/UC		
44	01/01/90	DRG/VETT/UC		
45	01/01/90	DRG/VETT/UC		
46	01/01/90	DRG/VETT/UC		
47	01/01/90	DRG/VETT/UC		
48	01/01/90	DRG/VETT/UC		
49	01/01/90	DRG/VETT/UC		
50	01/01/90	DRG/VETT/UC		

CRADLE-35

SCALE: 1:2
REF. DRG. NO. 24/1/0357/TG
DRG. NO. GCF TM-24/1 (F)
SHEET 1/1

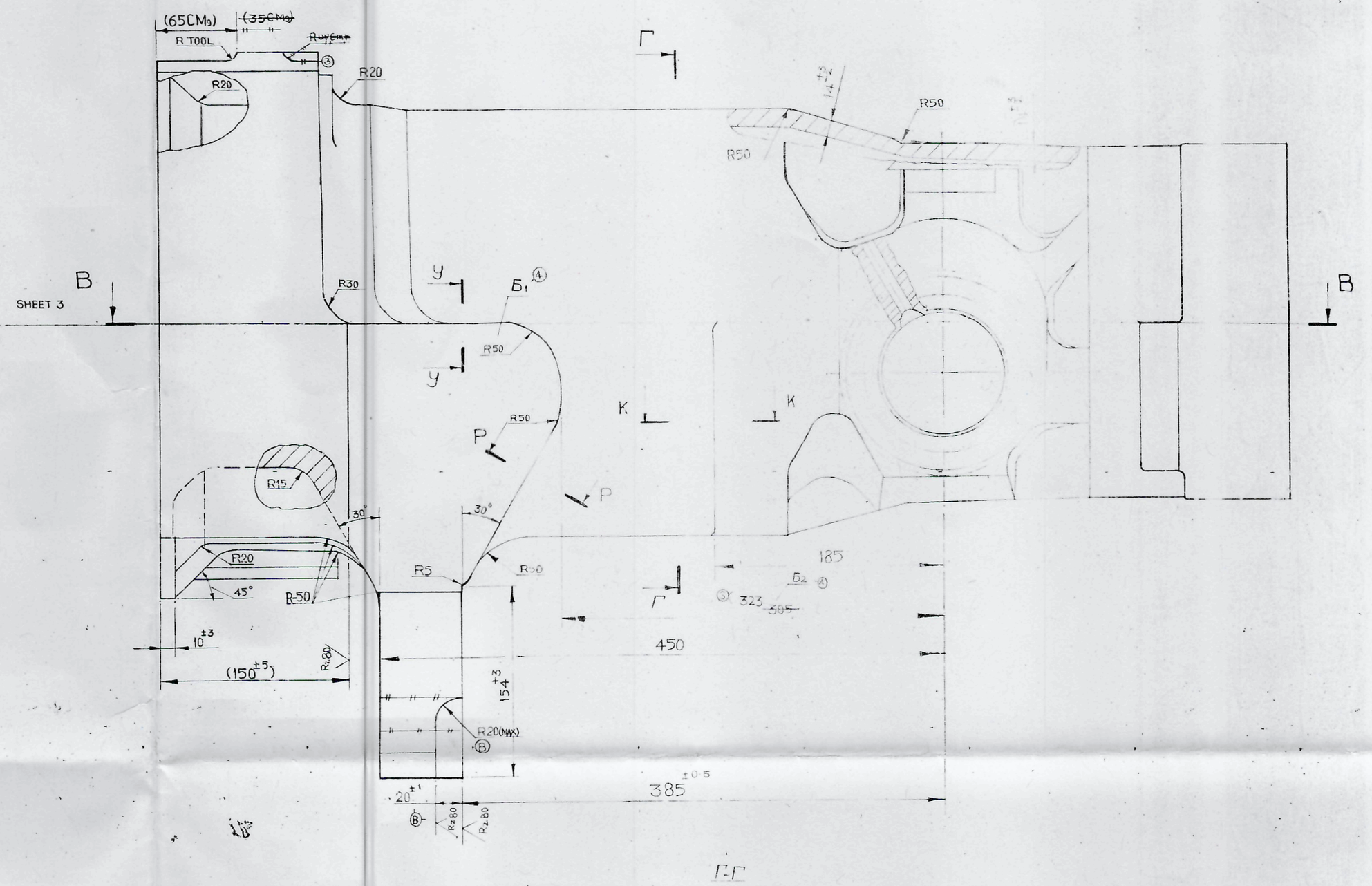
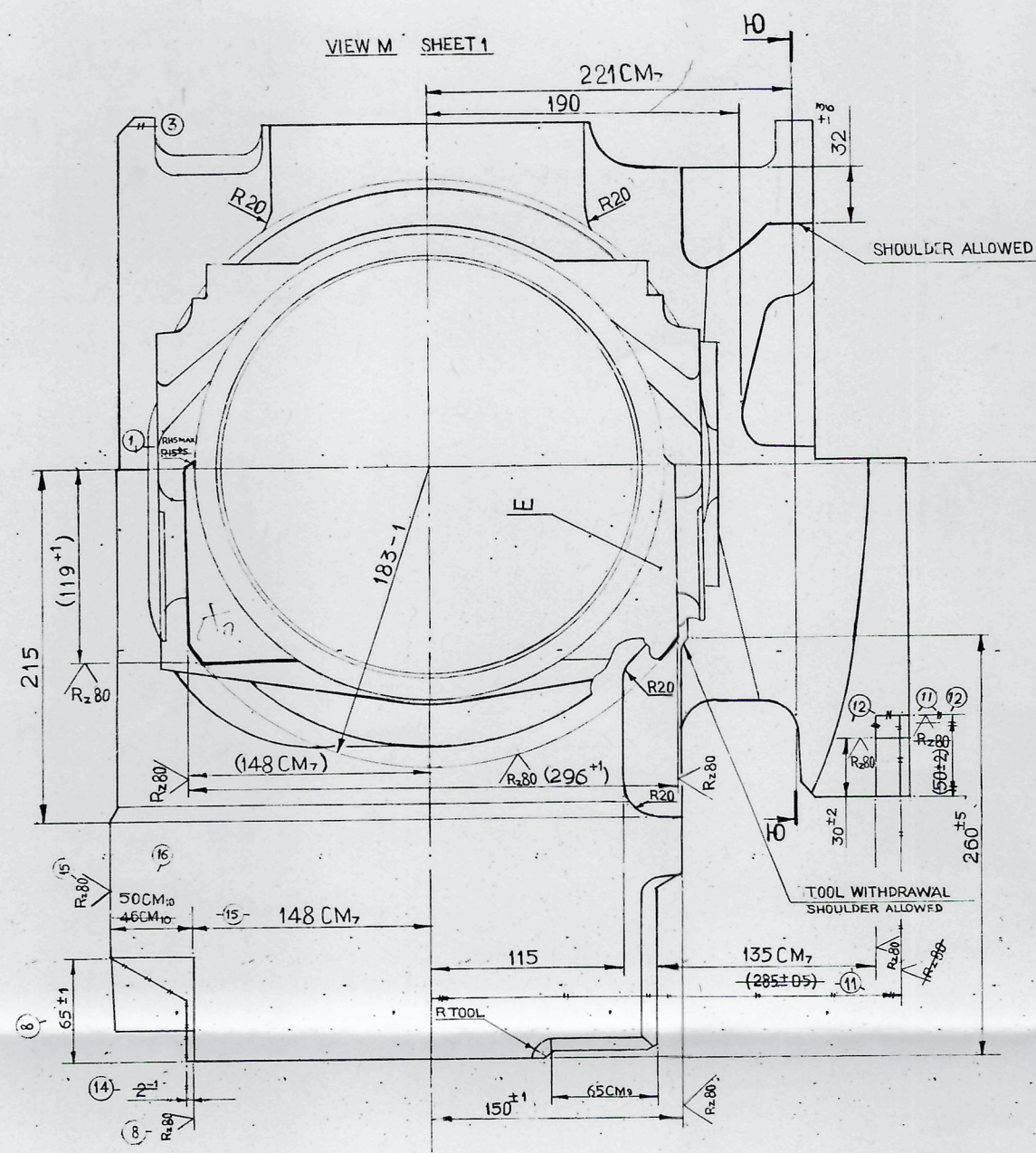

A-A

H-H

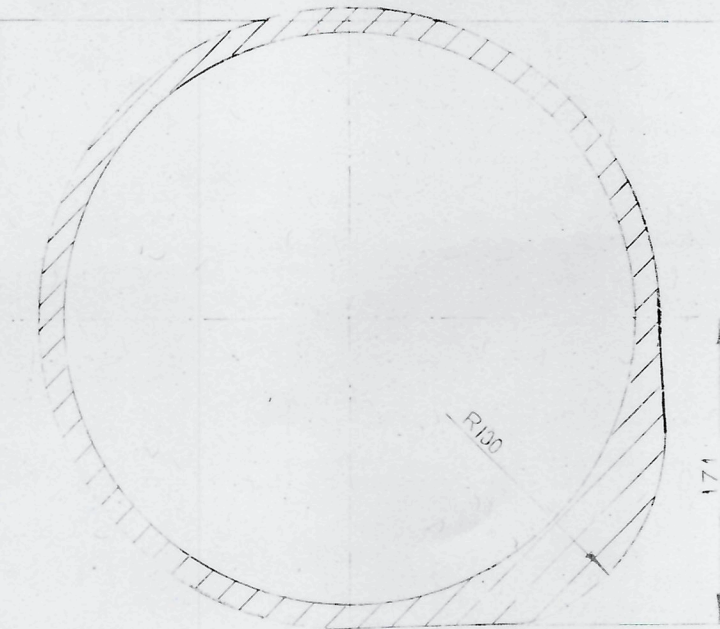
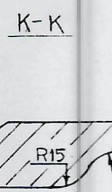
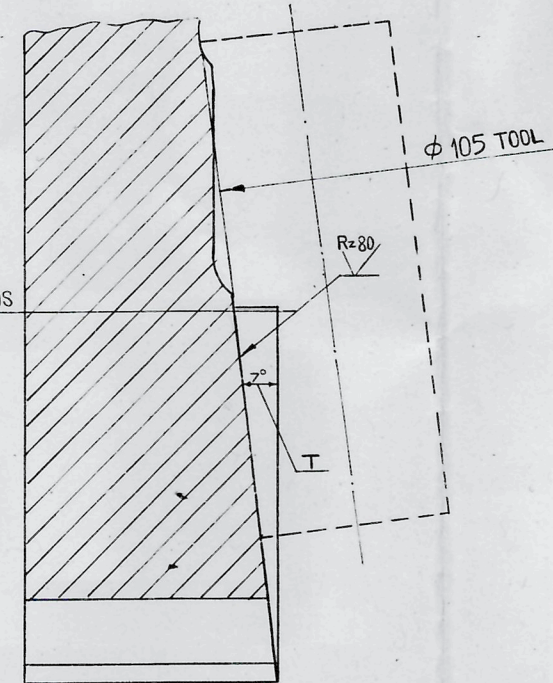
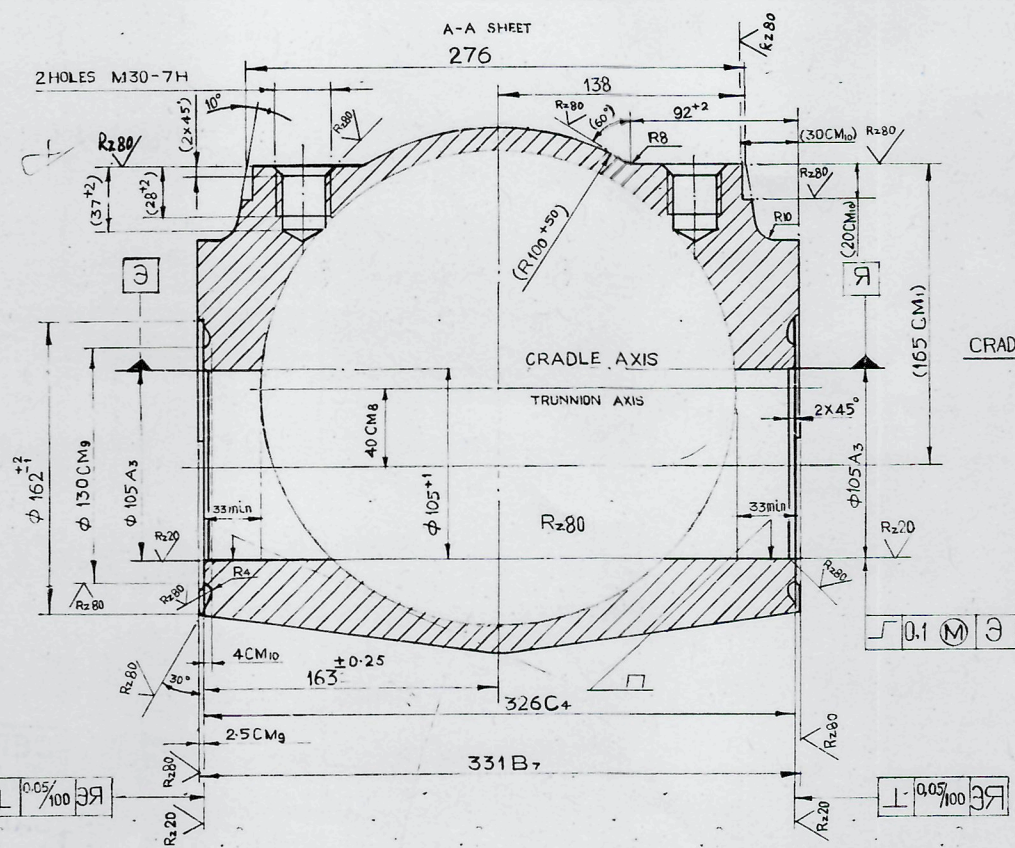

NOTE:-
 1. THIS DOCUMENT IS THE PROPERTY OF THE GOVT. OF INDIA, V.O.F.D. AND IS ISSUED FOR THE PURPOSE OF DEVELOPING/ MANUFACTURING STORES, REQUIRED FOR DEFENCE USE.
 2. IT MUST NOT BE REPRODUCED/DISCLOSED TO ANY THIRD PARTY OR USED FOR ANY CIVIL PURPOSE.
 3. IT MUST BE RETURNED TO THE ISSUING AUTHORITY WHEN THE PURPOSE OF ITS ISSUE HAS BEEN SERVED.
 4. PILOT SAMPLE TO BE APPROVED BEFORE BULK SUPPLY.

10	U36 1144
11	U36 1145
12	U36 1146
13	U36 1147
14	U36 1148
15	U36 1149
16	U36 1150
17	U36 1151
18	U36 1152
19	U36 1153
20	U36 1154

START No.	NUMBER	DATE	REVISIONS/DATE	RD	SITE	REMARKS
1	1	10.03				
2	2	10.03				
3	3	10.03				
4	4	10.03				
5	5	10.03				
6	6	10.03				
7	7	10.03				
8	8	10.03				
9	9	10.03				
10	10	10.03				
11	11	10.03				
12	12	10.03				
13	13	10.03				
14	14	10.03				
15	15	10.03				
16	16	10.03				
17	17	10.03				
18	18	10.03				
19	19	10.03				
20	20	10.03				

CRADLE क्रेडल

GUN CRADLE FACTORY, JABALPUR

DRG.No. GCF TM-24/2 (C)

SHEET OF

6-5 SHEET

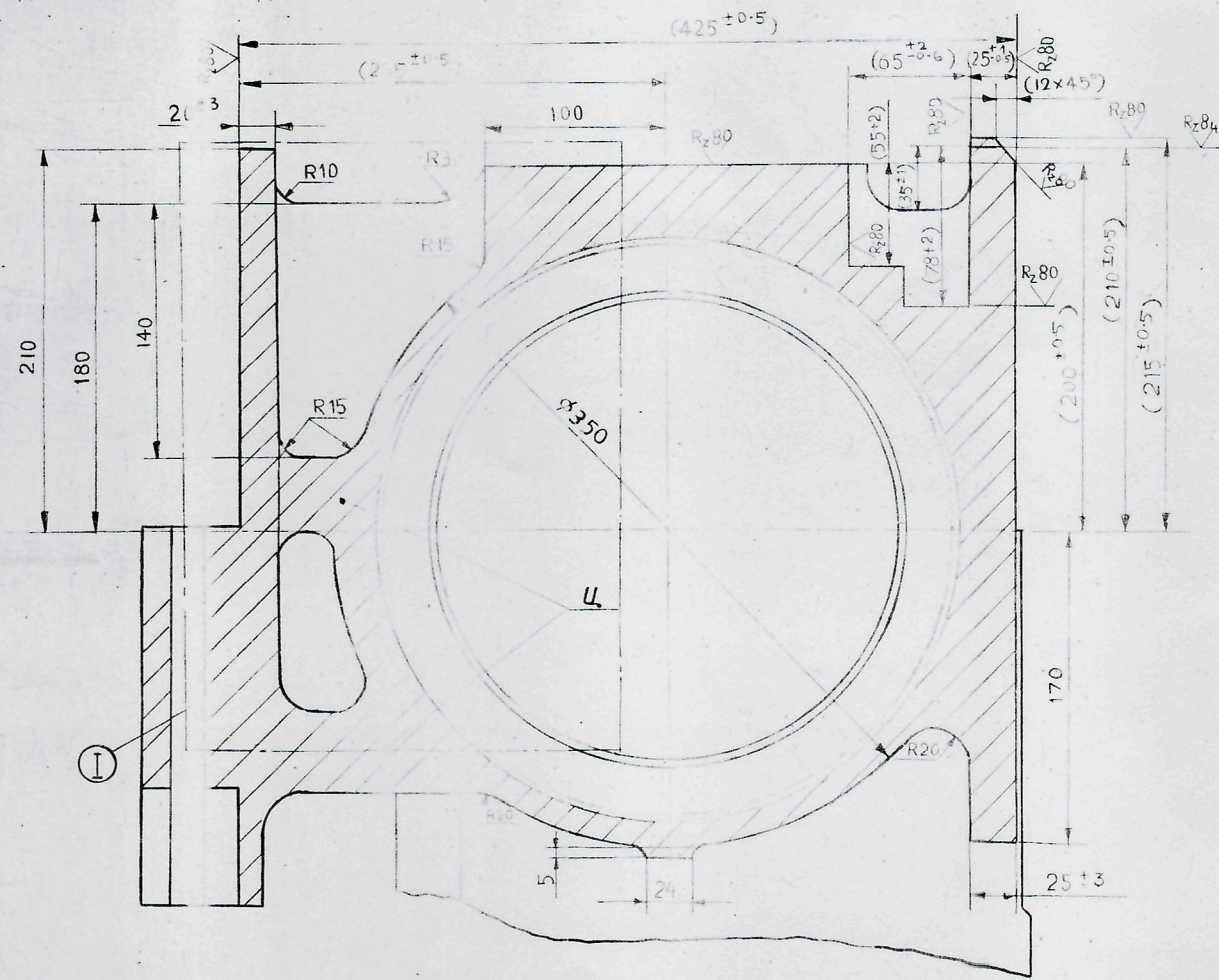

VIEW-H

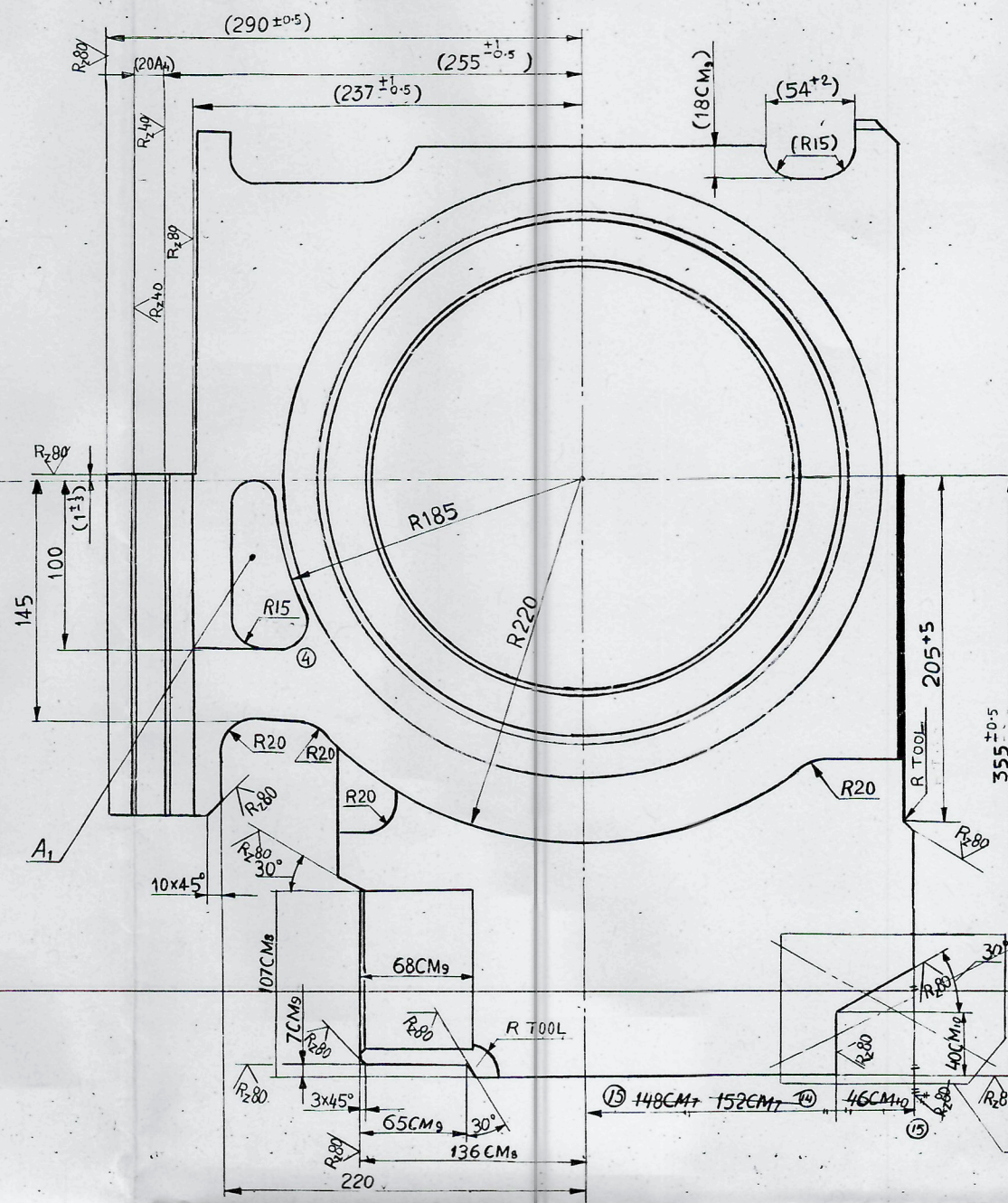

A-A SHEET 1

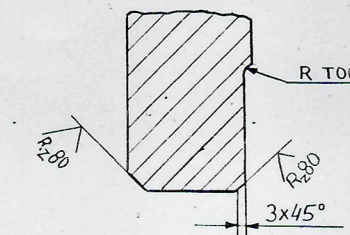

H-H SHEET 1

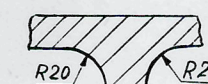

C-C SHEET 1

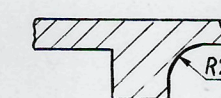

M-M SHEET 1

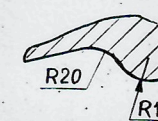

B-B SHEET

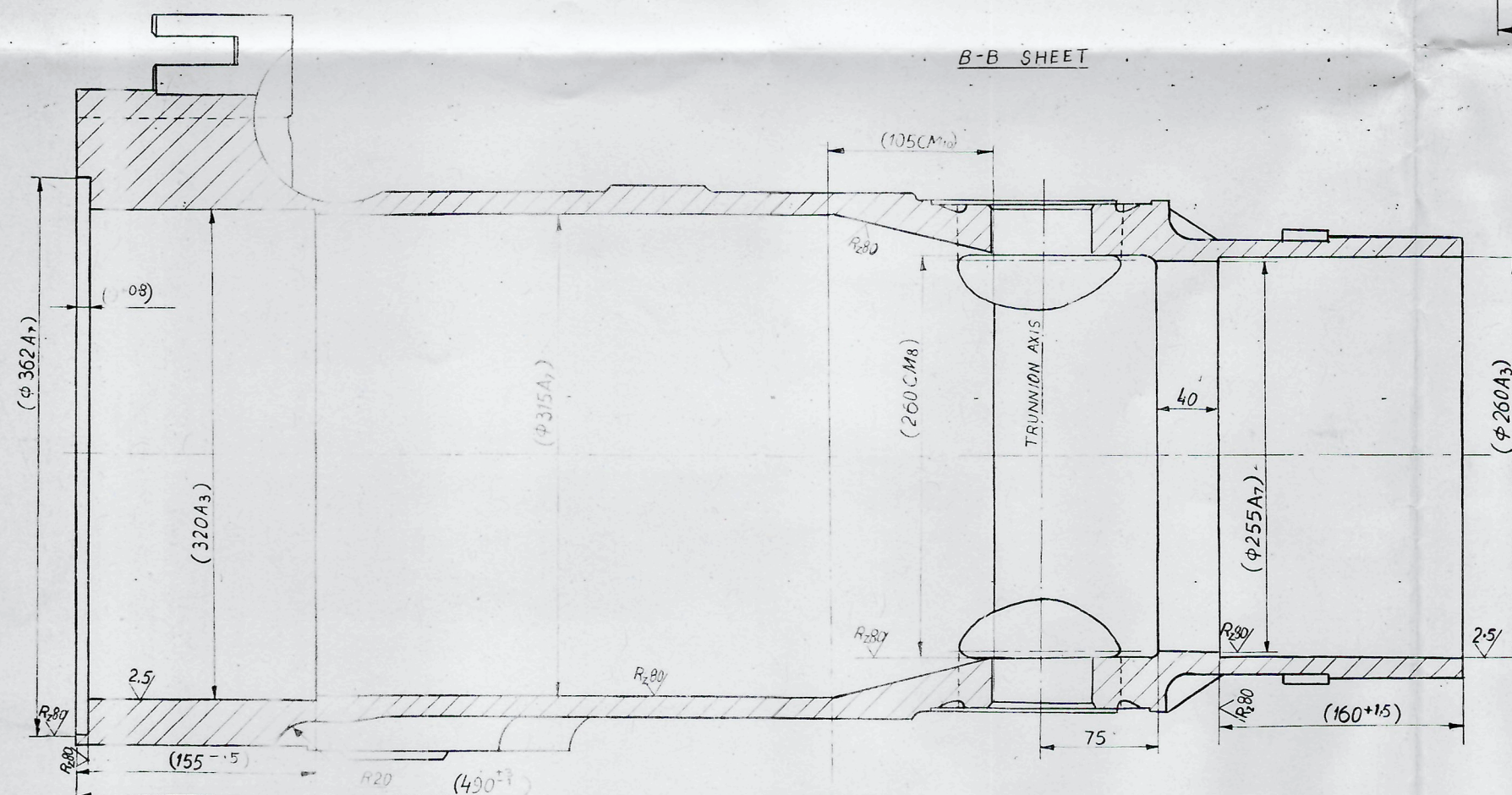

I ALTERNATIVE

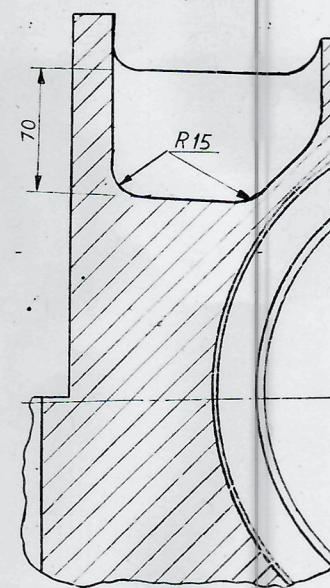

J-J SHEET 1

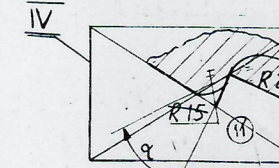

IV

INSTEAD OF CROSSED OUT

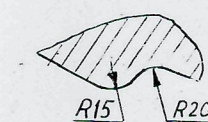

III

INSTEAD OF CROSSED OUT

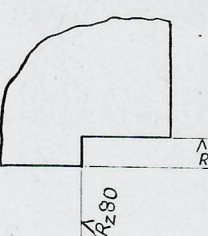

NOTE:-

- THIS DRAWING IS THE PROPERTY OF THE GOVT. OF INDIA. IT IS NOT TO BE REPRODUCED OR FOR THE PURPOSE OF DEVELOPING MANUFACTURING PROCEDURE WITHOUT THE WRITTEN PERMISSION OF THE GOVT. OF INDIA. IT MUST BE KEPT SECRET AND NOT DISCLOSED TO ANY THIRD PARTY OR USED FOR ANY CIVIL PURPOSE.
- IT MUST BE KEPT SECRET AND NOT DISCLOSED TO ANY THIRD PARTY OR USED FOR ANY CIVIL PURPOSE.
- IT MUST BE KEPT SECRET AND NOT DISCLOSED TO ANY THIRD PARTY OR USED FOR ANY CIVIL PURPOSE.
- PILOT SAMPLES MUST BE APPROVED BY THE BULK SUPPLY.

PHOTO	NOMENCLATURE	NO. OFF.	MATERIAL	HARDNESS	STANDARD	SIZE	REMARKS
	GEN. TOL. NOT SPECIFIED						
	LINEAR DIMENSIONS						
	ANGULAR DIMENSIONS						
	FINISH						
	INDEX						
	AMENDMENTS						
	SIGN.						
	DATE						
	PASSED						
	SEC.						
	M/J						
	SCALE						
	REF. DEF.						
	IND						
	1:2						
	DRG. NO.						
	M-24/3 (C)						
	SHEET						
	OF						
	GUN CARRIAGE FACTORY JABALPUR						