

**CONE RING ASSY  
FOR  
TAIL UNIT - TB-250**

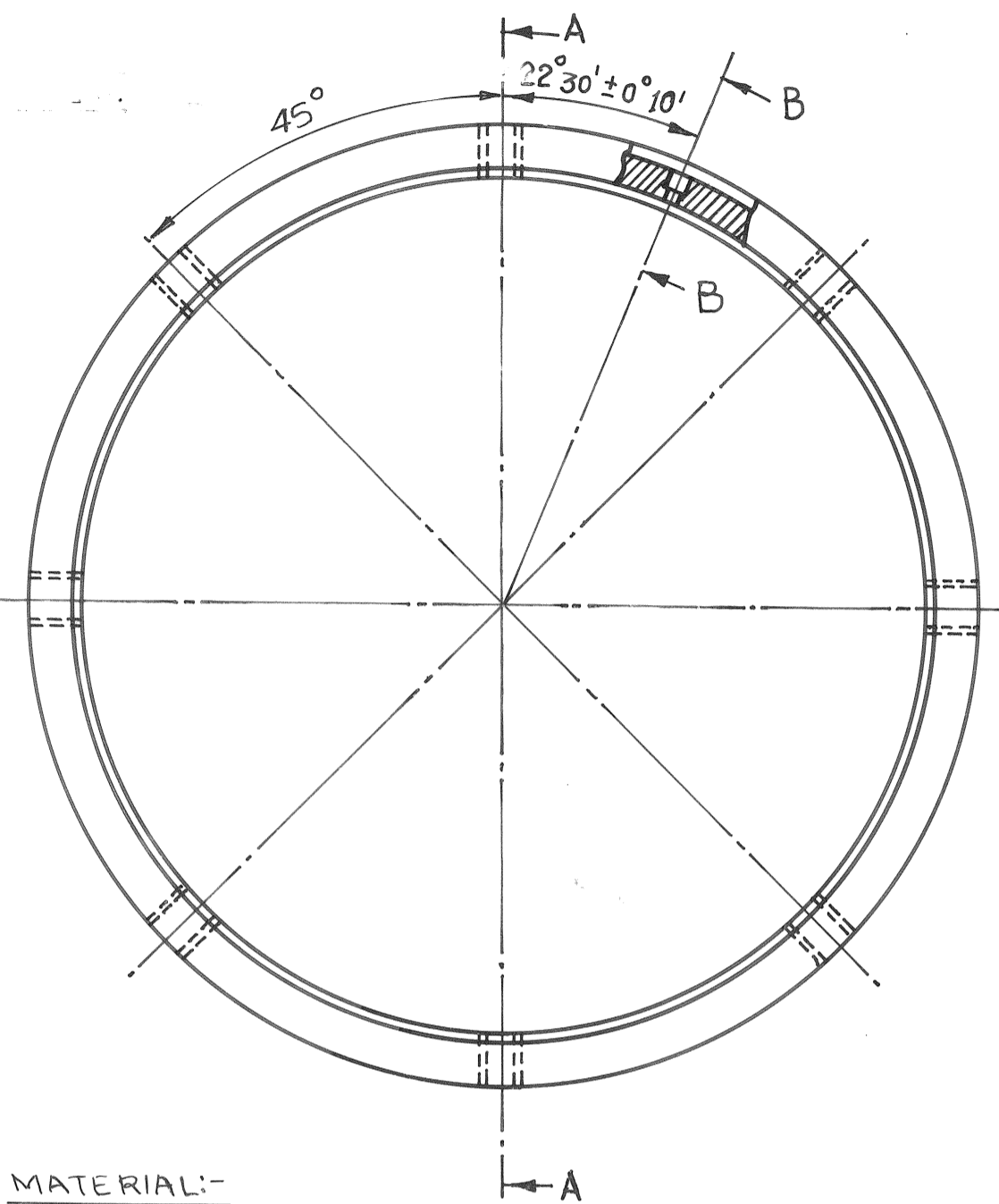

**MATERIAL:-**  
STEEL TO IS: 2004. CLASS-2  
OR. IS: 2062. Fe 410 WB.  
**PROTECTIVE FINISH:-**  
PHOSPHATED TO IS: 3618. CLASS- B.  
DRG. DRAWN BASED ON. ARDE - 9501-03. DET-5.

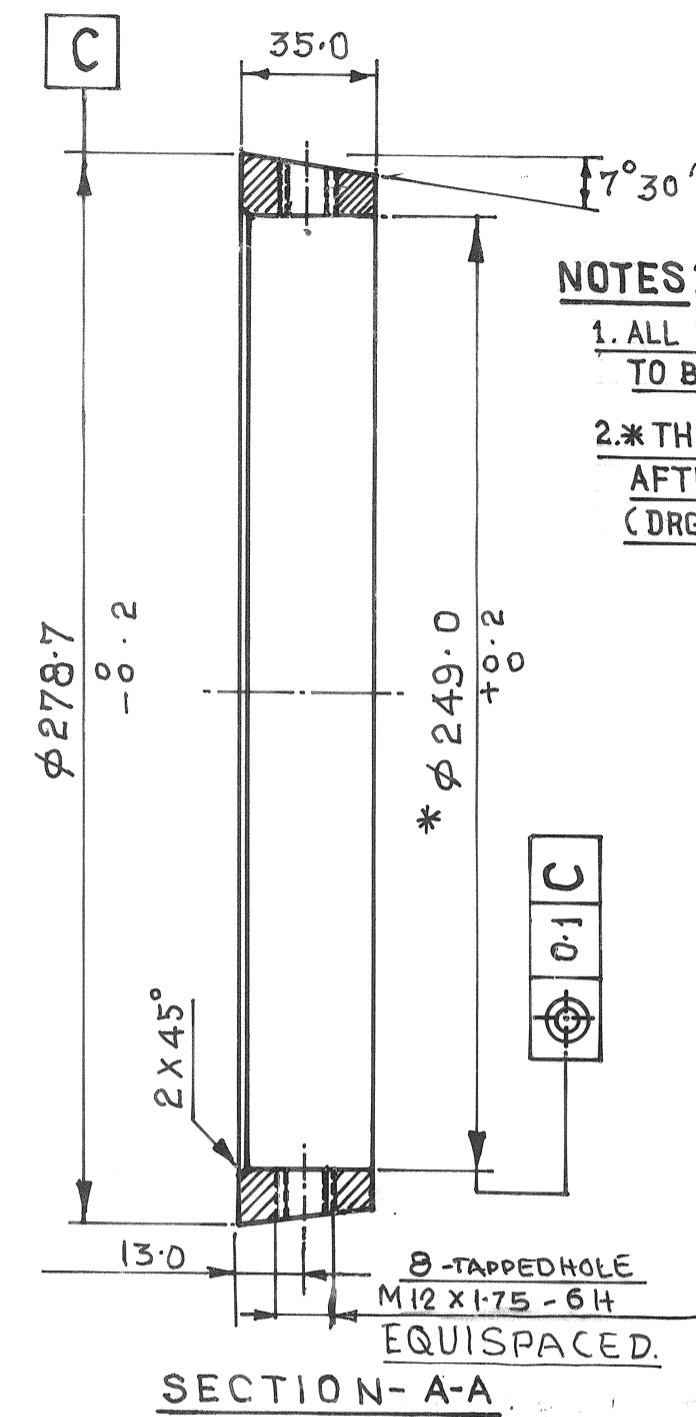

**NOTES:-**  
1. ALL SHARP EDGES & BURRS ARE TO BE REMOVED  
2. \* THIS DIMENSION IS TO BE CHECKED AFTER WELDING TO CONE BODY (DRG. NO. ARDE - 9501-03/2)

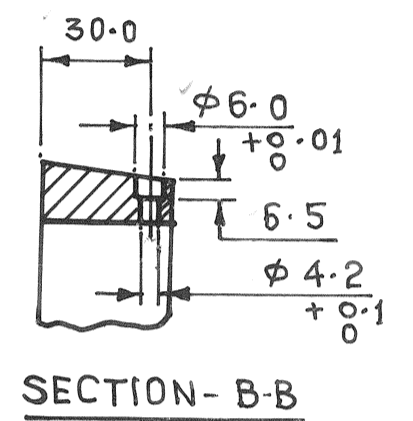

**SECTION - B-B**

IT. NO	NO OFF	MATL	DESCP.	SCALE
1	1	SEE ABOVE	CONE RING.	1:2

**NOTE:-**  
ALL SHARP EDGES & BURRS ARE TO BE REMOVED

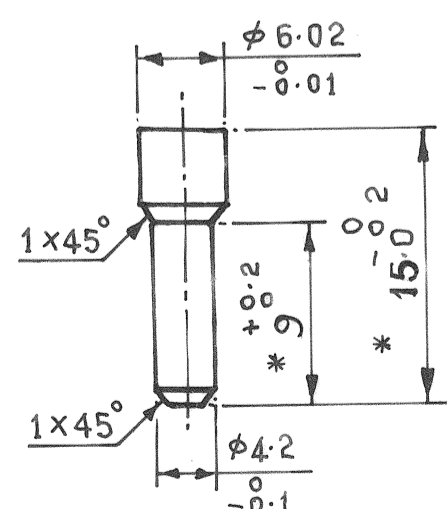

**MATL:-**  
STEEL TO IS: 2062 Fe 410 WB.  
PROTECTIVE FINISH.  
PHOSPHATED TO IS: 3618.  
CLASS- B.  
DRG. DRAWN BASED ON DRG. NO. ARDE-9501-03. DET- 6

\* VIDE RCMA L/NO- RCMA(AA)/1440/5/TECH DT. 21.06.2000

IT. NO	NO OFF	MATL.	DESCP.	SCALE
2	1	SEE ABOVE	LOCATING PIN.	2:1

DATE	ZONE	DESCRIPTION	ITEM NO. OFF	MATERIAL	DESCRIPTION
<b>AMENDMENT</b>			<b>LIST OF PARTS</b>		
THIRD ANGLE PROJECTION			COMPONENT :- CONE RING ASSY. FOR T.U. TB-250		
DIMENSIONS ARE IN M.M.			STORE DRG. NO. ARDE-9501-03 Det-4		
UNSPECIFIED TOLS. IS : 2102 (MEDIUM)			CONE RING ASSY. FOR TAIL UNIT. TB-250		
TRACED BY -			DRG. NO. SK-2420		
DRAWN BY - Poddler			SCALE :- 1:1, 2:1		
CHECKED BY - [Signature]			SCH. NO.		
PASSED BY -			OPN. NO.		
APPROVED BY - [Signature]			NO. OF SHEETS- 1		
			SHEET NO.- 1		

**ORDNANCE FACTORY DUMDUM**