

1. Hollow and dents of depth not exceeding 0.7 mm are allowed on unmachined surfaces.
2. Other requirements for forging are as per class II GOST 7505-74.
3. HB 285 to 229 (Ø 3.6 to 4.0).
4. Alternate material is 40 GOST 1050-74.
5. Unspecified radii should not exceed 3 mm.
6. Coating chemically, parkerized, accelerated, oiled.
7. Apply primer Ø?- 03 k GOST 9109-76 on unmachined surfaces and coat with protective enamel XB-518 TY 6-10-966-75.
8. Black-spots of any size are allowed on section A.

Ⓐ EQ. MATERIAL:- 45 C8 TO IS: 5517-93

Ⓑ EQ. MATERIAL:- CLASS 4.45 C8 TO IS: 2004-78

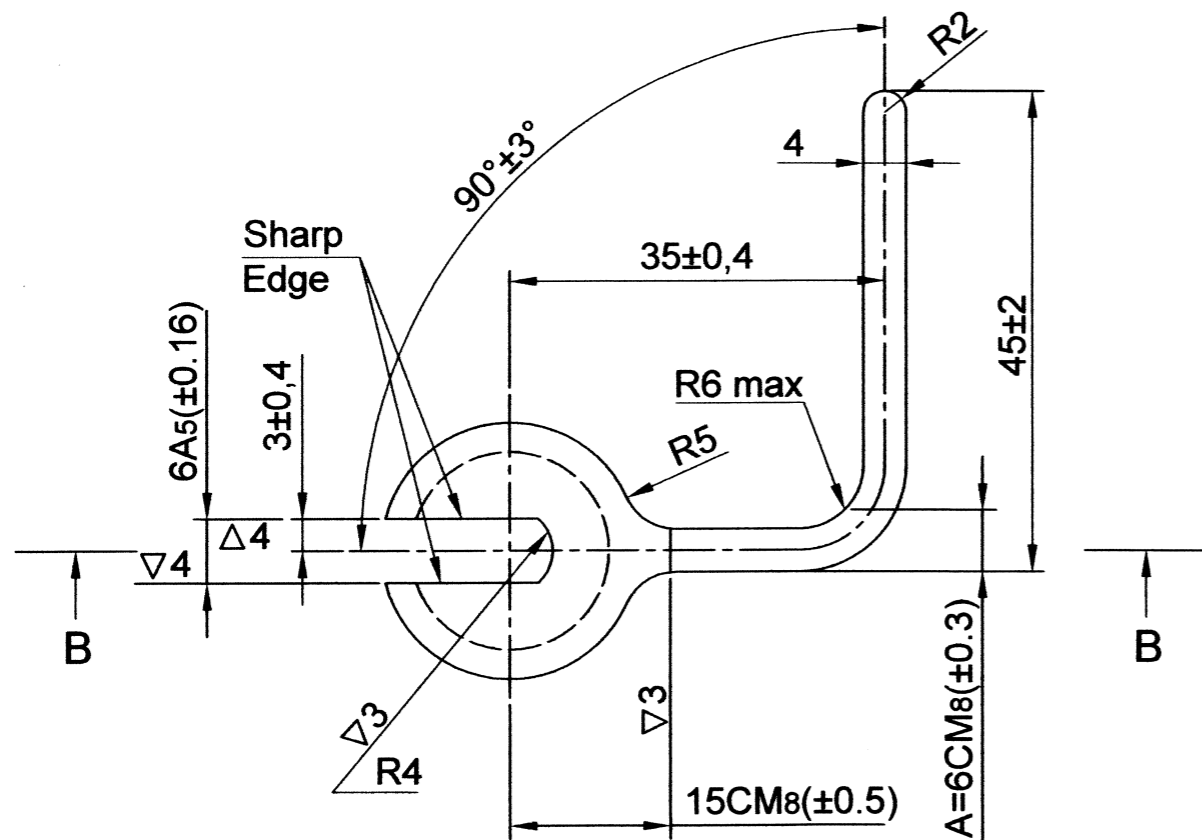

00849-ICV	Ⓑ	EQ. MATERIAL ADDED
16-01-2001		
00808-ICV	Ⓐ	EQ. MATERIAL ADDED
19-09-2000		
DC (I) No. DT	ISSUE	AMENDMENTS

765-58-221-C	SHEET WEIGHT	SCALE
HANDLE	0.042	
45 ГОСТ 1050-74		