

M.1216

REVISIONS

REVISIONS

ZONE	REV.	DESCRIPTION	DATE	APPROVED
	A	CREATED DRAWING	6/23/2009	DLA
	B	TIGHTENED TOLERANCE ON HEAD DIAMETER FROM -.010 TO -.005	7/6/2012	BAM

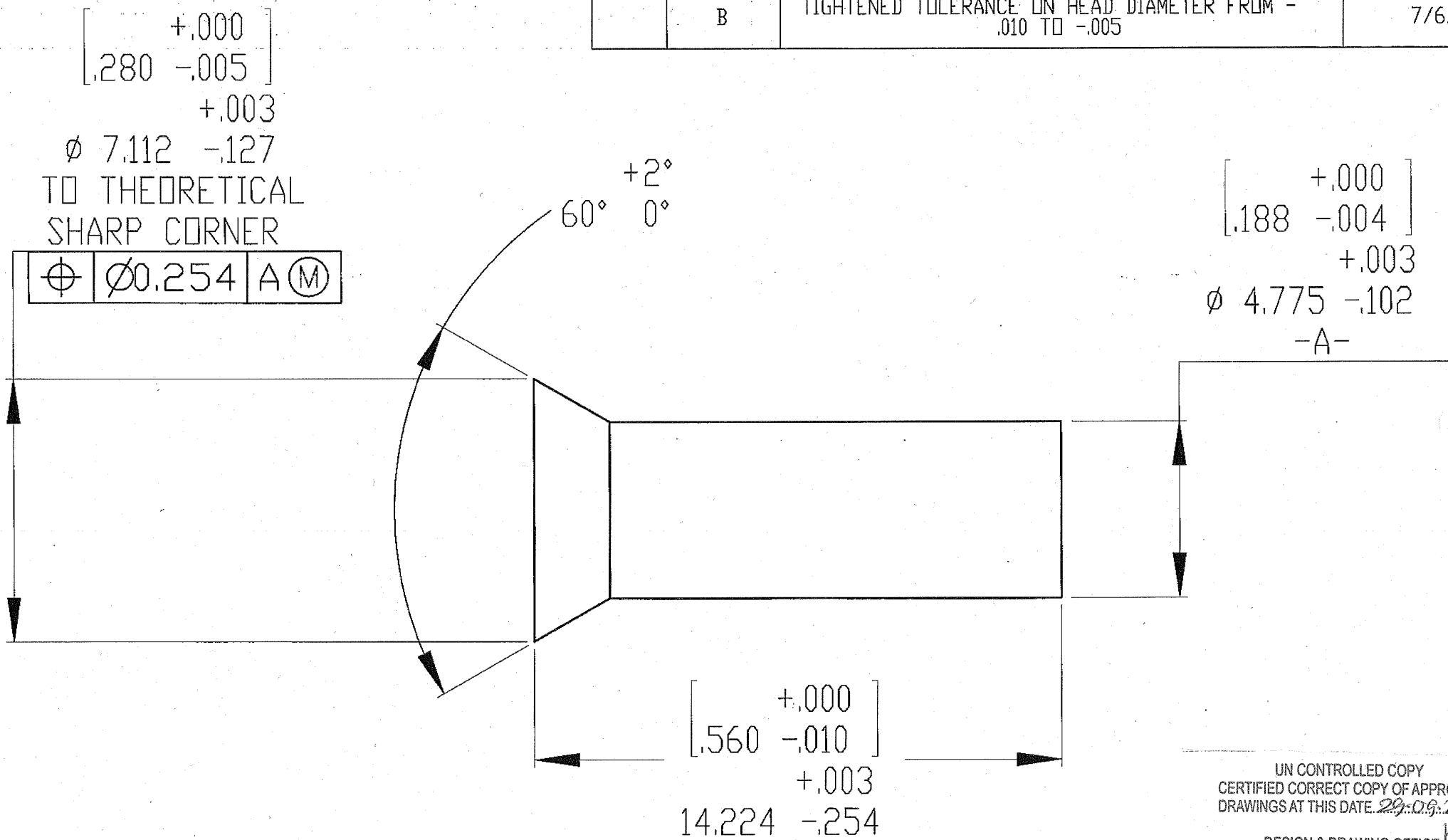

NOTES:

- BREAK EDGES 0.076 + 0.305 UNLESS OTHERWISE SPECIFIED.
- ASME Y14.5M-1994 APPLIES.

UN CONTROLLED COPY  
 CERTIFIED CORRECT COPY OF APPROVED DRAWINGS AT THIS DATE. 29.09.2021  
 DESIGN & DRAWING OFFICE,  
 ORDNANCE FACTORY, TIRUCHIRAPPALI-620 016.

4 AUG 2021  
 For Code (AP1)

PROPRIETARY AND CONFIDENTIAL  
 THE INFORMATION CONTAINED IN THIS DRAWING IS THE SOLE PROPERTY OF OHIO ORDNANCE WORKS, INC. ANY REPRODUCTION IN PART OR AS A WHOLE WITHOUT THE WRITTEN PERMISSION OF OHIO ORDNANCE WORKS, INC. IS PROHIBITED.

UNLESS OTHERWISE SPECIFIED	NAME	DATE
DIMENSIONS ARE IN MM/[INCHES] ALL THREAD DIM. ARE IN INCHES	DRAWN ALBRIGHT	06/23/09
TOLERANCES:	CHECKED	
FRACTIONAL ±0.015	ENG APPR.	
ANGULAR: MACH ±1°	MFG APPR.	
TWO PLACE DECIMAL ±0.25	Q.A.	
THREE PLACE DECIMAL ±0.127	COMMENTS:	
INTERPRET GEOMETRIC TOLERANCING PER:		
MATERIAL AISI 1018		
FINISH NONE		
DO NOT SCALE DRAWING		

OHIO ORDNANCE WORKS, INC.		
RIVET, TOP & BOTTOM PLATE, 00W50BMG		
SIZE A	5009387	REV B
SCALE: 5:1	WEIGHT:	SHEET 1 OF 1