

GEN. TOL. AS PER IS: 2102 MEDIUM CLASS					
GRADE	0.5	3	6	30	100
UP TO	3	6	30	100	
EXHALATION	±0.1	±0.1	±0.2	±0.3	

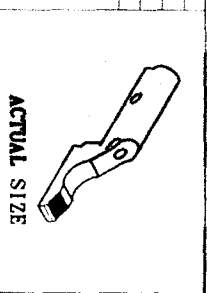

DRG. SEALED
ON:
[Signature]
(R.K. SINGH)
JT. GENERAL MANAGER
FOR GENERAL MANAGER

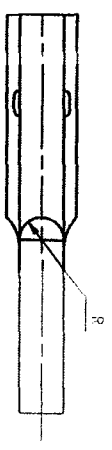
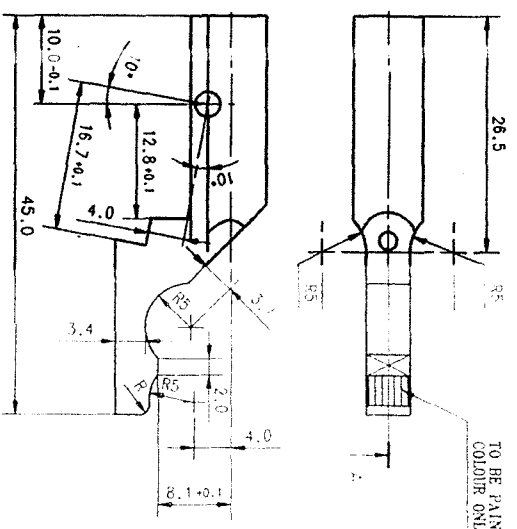
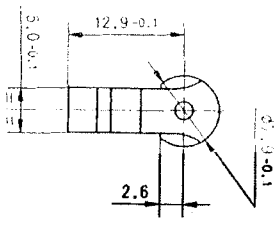
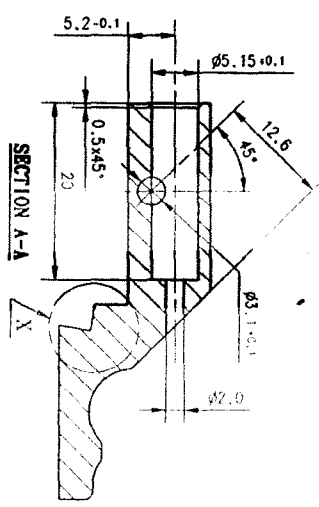

NOTE :- 1. ALL THE SHARPE EDGES AND BURRS ARE TO BE REMOVED
2. ALL DIMENSIONS ARE IN mm.
3. ALL UNTOLERATED DIMENSIONS ARE TO BE STRICTLY MAINTAINED
AS PER IS:2102 CLASS MEDIUM

MATERIAL :- BS:970 PT.1 1983, GD:708M40 [EN 19A(T)]

TREATMENT :- PORTION SHOWN WITHIN 'X' TO BE HARDENED & TEMPERED TO 450-550 H.V.

FINISH :- PHOSPHATED TO SPECN. JSS:0465/01-1998 CLASS II OIL FINISH.

ASSY. DRAWING NO. TSP-100

INDIAN ORDNANCE FACTORIES
RIFLE FACTORY
ISHAPORE

FIRING PIN NUT
30-06 SPORTING RIFLE

2011	NAME	DATE
DESIGNED	<i>[Signature]</i>	12/01/11
DRAWN		
CHECKED		
APPROVED		

DRAWING NUMBER
TSP-100

DI	DC	DT	NO.	REVISION	DATE	BY	CHKD	APPD
16.	08C/011/07			NEW MATERIAL SPECIFICATION ADDED FOR BS:970 EN 10 (T) FOR BS:970 GR.1 1983 GD:709 M40 [EN 19A(T)] HARDNESS CHANGED FOR 450-500 H.V. [EN 19A(T)]				S.D. D GUPTA
12.	08C/041/08			MATERIAL SPECIFICATION CHANGED FOR BS:970 GR.1 1983 GD:709 M40 [EN 19A(T)] READ BS:970 PT.1 1983 GD:709 M40 [EN 19A(T)]				S.D. D GUPTA
12.	08C/101/11			MATERIAL SPECIFICATION CHANGED FOR BS:970 GR.1 1983 GD:709 M40 [EN 19A(T)] READ BS:970 PT.1 1983 GD:709 M40 [EN 19A(T)] NEW NECK TIVE PREPARED VIDE D.C REF 1 NO. 08C/101/11 DATE 12-01-2011				<i>[Signature]</i>