

DRG. No. 29P 0052

DIMENSIONS ARE IN mm.
INFORMATION MARKED THUS 'T' TO BE MARKED ON
UNTOLERATED DIMENSIONS AS PER IS. 2102 (MEDIUM)

MAJ. DIA. 4.50	-0.090
EFF. DIA. 4.013	-0.056
MIN. DIA. 3.58	-0.110

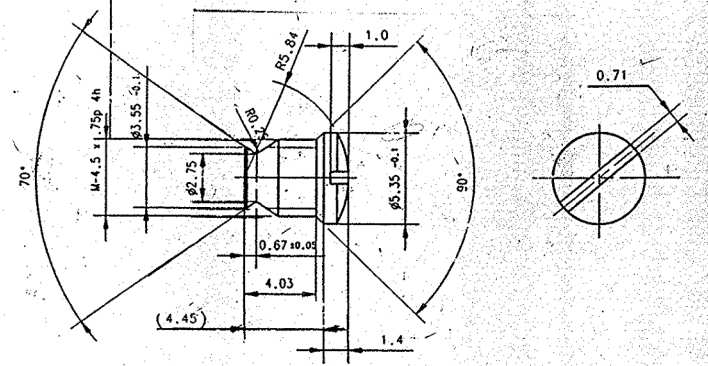

SCALE-4:1



NOTE :- HEAD OF SCREW TO BE POLISHED BEFORE HARDENING AND PHOSPHATING

MATERIAL :- STEEL BS 970 Pt.1:1983 GR. 80 M-50

TREATMENT :- HARDENED & TEMPERED TO H.V. 300-400

PROTECTIVE FINISH :- PHOSPHATE TO SPECN. JSS 0465-01:1988
 CLASS I OIL FINISH

PART NO.	DESCRIPTIONS	NO OFF	MATERIAL	TREATMENT	REMARKS

 TRACED DRAWN CHECKED OIC/D&DO PRDN. OFFICER DIV. OFFICER D&DO	SIGNATURE & DATE	SUB: SCREW. EJECTOR	SCALE
		FOR: .315" SPORTING RIFLE	4:1
		DES. REF. NO: DS CAT No. 5305-005021	STORE DRG. NO.
		DRG. NO: 29P 0052	OPERATION NO.
		 ORDNANCE FACTORY TIRUCHIRAPALLI-16.	SHEETS:
AMENDMENTS	SIG. & DATE	APPROVED ON:	SHEET NO: